

由 Autodesk 教育版产品制作

修 订	标 记	修 改 描 述	签 名	日 期
REV	NO.	DESCRIPTION	SIGNATURE	DATE
		NEW DRG		2016-03-12

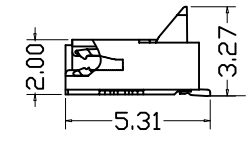
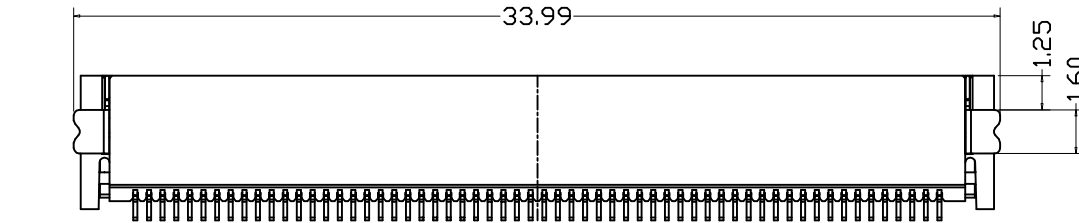
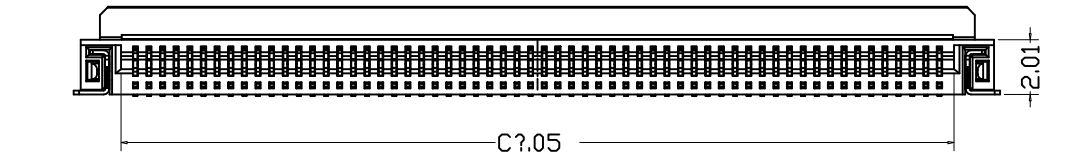
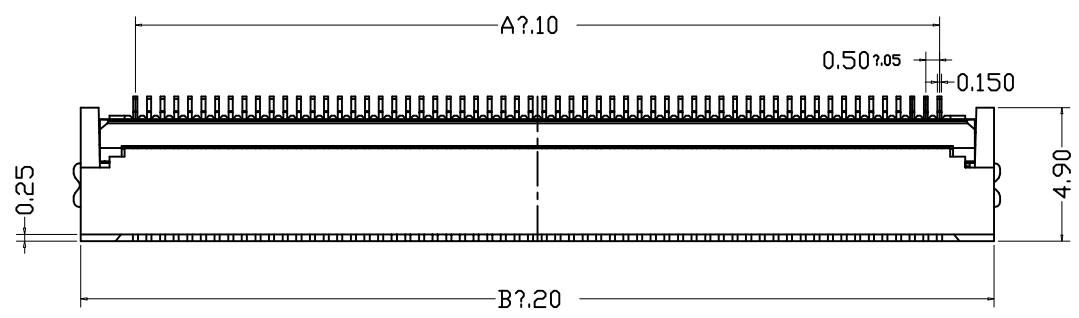

- NOTES:
- MATERIAL:  
HOUSING: HIGHT-TEMP PLASTIC,UL 94-V0,COLOR:NATURE;  
COVER: HIGHT-TEMP PLASTIC,UL 94-V0,COLOR:BLACK;  
CONTACT: COPPER ALLOY;  
LEG: Brass;
  - PLATING:  
CONTACT: GOLD OR TIN PLATED ON NICKEL OVERALL.  
LEG: TIN PLATED ON NICKEL OVERALL.
  - RATING:  
CURRENT RATING: 0.5A AC/DC  
VOLTAGE RATING: 25V AC/DC  
TEMPERATURE RANGE: -25?~+85?;
  - PART NO:

PIN NO.	DIM.A	DIM.B	DIM.C	PIN NO.	DIM.A	DIM.B	DIM.C	PIN NO.	DIM.A	DIM.B	DIM.C
4	1.50	5.50	2.56	24	11.50	15.50	12.56	44	21.50	25.50	22.56
5	2.00	6.00	3.06	25	12.00	16.00	13.06	45	22.00	26.00	23.06
6	2.50	6.50	3.56	26	12.50	16.50	13.56	46	22.50	26.50	23.56
7	3.00	7.00	4.06	27	13.00	17.00	14.06	47	23.00	27.00	24.06
8	3.50	7.50	4.56	28	13.50	17.50	14.56	48	23.50	27.50	24.56
9	4.00	8.00	5.06	29	14.00	18.00	15.06	49	24.00	28.00	25.06
10	4.50	8.50	5.56	30	14.50	18.50	15.56	50	24.50	28.50	25.56
11	5.00	9.00	6.06	31	15.00	19.00	16.06	51	25.00	29.00	26.06
12	5.50	9.50	6.56	32	15.50	19.50	16.56	52	25.50	29.50	26.56
13	6.00	10.00	7.06	33	16.00	20.00	17.06	53	26.00	30.00	27.06
14	6.50	10.50	7.56	34	16.50	20.50	17.56	54	26.50	30.50	27.56
15	7.00	11.00	8.06	35	17.00	21.00	18.06	55	27.00	31.00	28.06
16	7.50	11.50	8.56	36	17.50	21.50	18.56	56	27.50	31.50	28.56
17	8.00	12.00	9.06	37	18.00	22.00	19.06	57	28.00	32.00	29.06
18	8.50	12.50	9.56	38	18.50	22.50	19.56	58	28.50	32.50	29.56
19	9.00	13.00	10.06	39	19.00	23.00	20.06	60	29.50	33.50	30.56
20	9.50	13.50	10.56	40	19.50	23.50	20.56				
21	10.00	14.00	11.06	41	20.00	24.00	21.06				
22	10.50	14.50	11.56	42	20.50	24.50	21.56				
23	11.00	15.00	12.06	43	21.00	25.00	22.06				

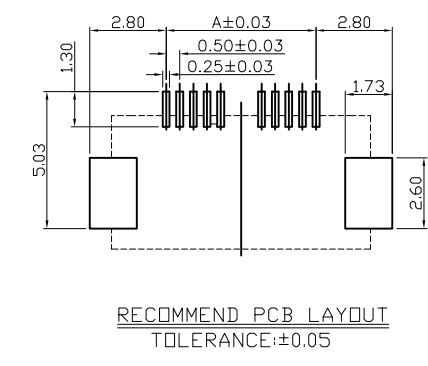
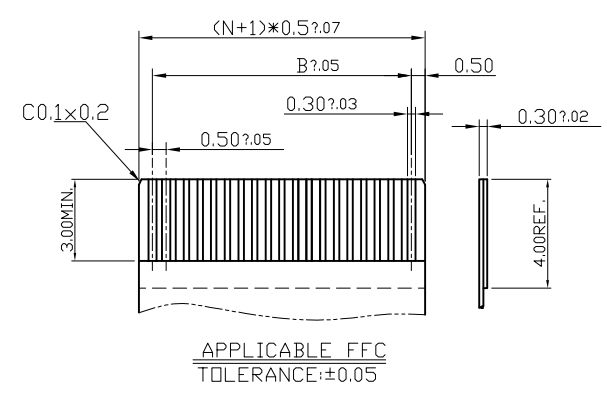



深圳市华德共创科技有限公司  
Shenzhen Huade co-create Technology Co.,LTD  
电话: 0755-27111225 传真: 0755-29940187

-TOLERANCES- UNLESS OTHERWISE SPECIFIED 公差参数表		 	TITLE: 产品名称: FPC 0.5间距2.0高前插后掀式					
X.X	±0.30	X.X*	±3°	APPD: 核准:	PART NO: 产品编号: 0520-HX-nPWB			
X.XX	±0.20	X.XX*	±2°	CHECK: 校对: 王建业	DATE	SCALE	UNIT	CODE NUMBER
X.XXX	±0.10	X.XXX*	±1°	DRAW: 绘图: 黄艳兰	2016-03-12	1:1	mm	A001

由 Autodesk 教育版产品制作