

MOLEX P/N		LENGTH (m)
Plenum	LSZH, Riser	
885371501	885376501	1.0 +0.1/-0
885371502	885376502	2.0 +0.1/-0
885371503	885376503	3.0 +0.1/-0
885371504	885376504	4.0 +0.1/-0
885371505	885376505	5.0 +0.1/-0
885371507	885376507	7.0 +0.1/-0
885371508	885376508	8.0 +0.1/-0
885371510	885376510	10.0 +0.1/-0
885371515	885376515	15.0 +0.2/-0
885371520	885376520	20.0 +0.2/-0
885371525	885376525	25.0 +0.3/-0
885371530	885376530	30.0 +0.3/-0
885371540	885376540	40.0 +0.4/-0
885371560	885376560	60.0+0.6/-0
885371575	885376575	75.0+0.75/-0
885371590	885376590	90.0+0.90/-0
885371600	885376600	100.0 +1.0/-0
885371620	885376620	120.0 +1.2/-0
885371650	885376650	150.0 +1.5/-0
885371700	885376700	200.0 +2.0/-0
885371800	885376800	300.0 +3.0/-0

CONNECTIONS	
FROM	TO
P1-A	P2-B
P1-B	P2-A

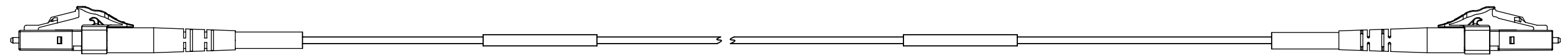
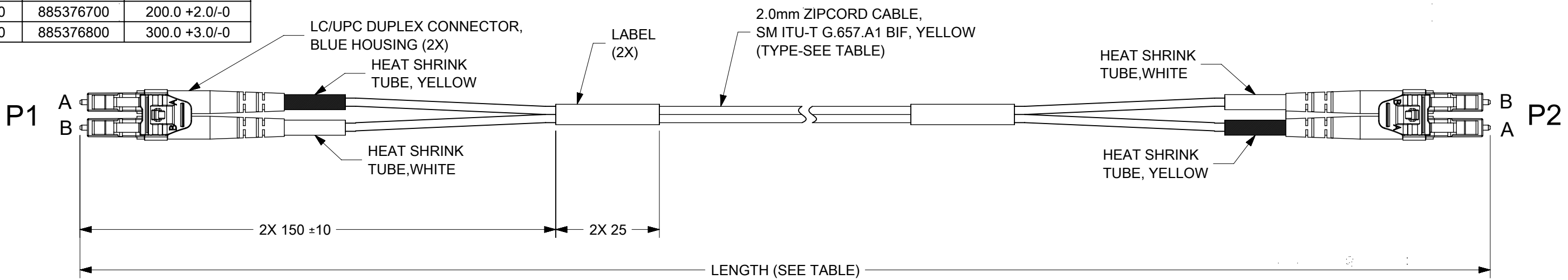

- NOTES:
- DUST CAPS ARE INCLUDED, BUT NOT SHOWN.
 - LABEL CONTENT: MOLEX P/N AND SERIAL NUMBER.
 - MAXIMUM INSERTION LOSS PER CONNECTOR @ 1310nm: 0.35dB.
MAXIMUM RETURN LOSS PER CONNECTOR @ 1550nm: -50dB.
 - CABLE'S BEND RADII:
INSTALLATION: 60mm
OPERATING: 30mm

THIS DRAWING CONTAINS INFORMATION THAT IS PROPRIETARY TO MOLEX ELECTRONIC TECHNOLOGIES, LLC AND SHOULD NOT BE USED WITHOUT WRITTEN PERMISSION									
DIMENSION UNITS	SCALE	CURRENT REV DESC:							
mm	NTS								
GENERAL TOLERANCES (UNLESS SPECIFIED)		EC NO: 710768			LCD TO LCD 2.0MM SM ZIPCORD CABLE JUMPER, YELLOW				
ANGULAR TOL ± 0.5°		DRWN: JHUANG18 2022/06/30							
4 PLACES	±	CHKD: IGUMIN 2022/07/11			PRODUCT CUSTOMER DRAWING				
3 PLACES	±	APPR: IGUMIN 2022/07/11							
2 PLACES	±	INITIAL REVISION:			DOCUMENT NUMBER: 885371501				
1 PLACE	±	DRWN: SDXIE 2019/06/14							
0 PLACES	±	APPR: WCHEN 2019/07/15			DOC TYPE: PSD DOC PART: 000 REVISION: D				
DRAFT WHERE APPLICABLE MUST REMAIN WITHIN DIMENSIONS		THIRD ANGLE PROJECTION	DRAWING	SERIES					
			B-SIZE	88537	SEE TABLE		GENERAL MARKET		1 OF 1