

DESIGNED AND DIMENSIONED IN MILLIMETERS [INCHES]
ALL DIMENSIONS REFERENCE EXCEPT AS SHOWN

DO NOT SCALE FROM THIS PRINT

THIS PRODUCT MANUFACTURED WITH LEAD-FREE PROCESSING

RF23C-XXXX-XXXX-XXXX

CABLE CALLOUT
23C: MWC-2350CU-01 CABLE

OVERALL ASSEMBLY LENGTH (OAL)
XXXX (MILLIMETERS)
(0100 MIN)
(SEE NOTE 6)

END 1 CONNECTOR
(SEE TABLE 2, SHT 2)

END 2 CONNECTOR
(SEE TABLE 2, SHT 2)

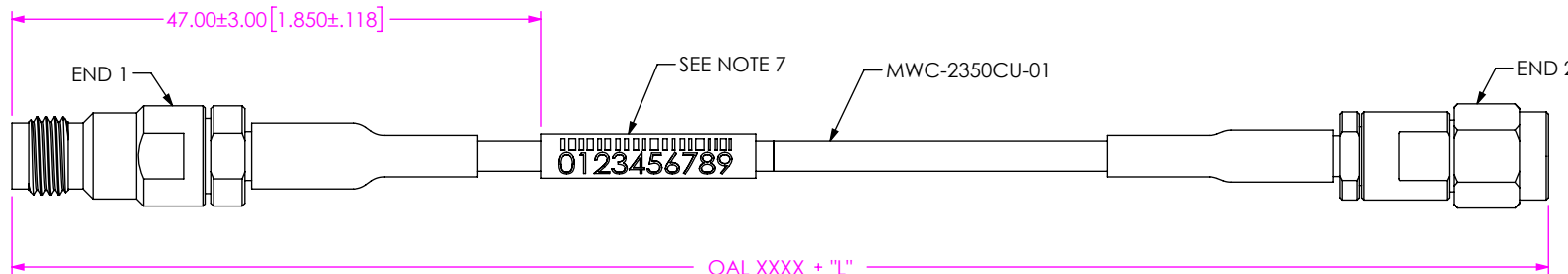

FIG 1
RF23C-24SJ-92SP-XXXX SHOWN
(PROTECTIVE CAPS NOT SHOWN FOR CLARITY)

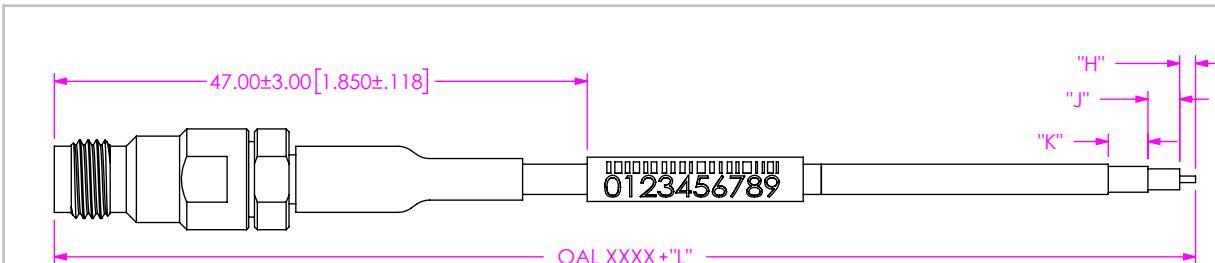

FIG 8
RF23C-24SJ-102030-XXXX SHOWN (SEE NOTE 8 & 9)

"K" FORMAT: X.X
"J" FORMAT: X.X
"H" FORMAT: X.X

DO NOT LEAVE ANY SPACE BLANK,
EACH MUST CONTAIN A
NUMERIC CHARACTER 0 THRU 9

TABLE 1	
OVERALL LENGTH	"L"
0100-0300 [5.98-11.81]	+5.0 [.20] / -0.0 [.00]
0301-1500 [11.85-59.01]	+12.0 [.47] / -0.0 [.00]
1501-3000 [59.09-118.11]	+25.0 [.98] / -0.0 [.00]
3001-7500 [118.15-295.28]	+50.0 [1.97] / -0.0 [.00]
7501-9999 [295.31-393.67]	+1% / -0.0 [.00]

NOTES:

- NOTE DELETED.
- NOTE DELETED.
- CONNECTORS TO BE ORIENTED ACCORDING TO CO-RF-WI-3048-M.
- CABLE ASSEMBLY TO HAVE PROTECTIVE CAP ASSEMBLED ON EACH END AND TO BE INDIVIDUALLY PACKAGED IN ESD BAG.
- NOTE DELETED.
- CABLE LENGTHS LONGER THAN 1000 MILLIMETERS ARE NOT SUPPORTED BY S.I. TEST DATA.
- ASSEMBLY TO BE 100% TESTED FOR RETURN LOSS AND INSERTION LOSS. LABEL EACH INDIVIDUAL CABLE ASSEMBLY WITH 1 LABEL-SER-02. RETURN LOSS SPECIFICATION IS EQUAL TO THE HIGHEST END OPTION LIMIT.
- DIM "H", "J", AND "K" HAVE A MINIMUM VALUE OF 0.0mm & A MAXIMUM VALUE OF 9.9mm [.39"].
- FOR STRIPPED AND TINNED OPTION, BOTH THE CENTER CONDUCTOR IS TINNED.

PROPRIETARY NOTE
THIS DOCUMENT CONTAINS CONFIDENTIAL AND PROPRIETARY INFORMATION AND ALL DESIGN, MANUFACTURING, REPRODUCTION, USE, PATENT RIGHTS AND SALES RIGHTS ARE EXPRESSLY RESERVED BY SAMTEC, INC. THIS DOCUMENT SHALL NOT BE DISCLOSED, IN WHOLE OR PART, TO ANY UNAUTHORIZED PERSON OR ENTITY NOR REPRODUCED, TRANSFERRED OR INCORPORATED IN ANY OTHER PROJECT IN ANY MANNER WITHOUT THE EXPRESS WRITTEN CONSENT OF SAMTEC, INC.

MATERIAL: DO NOT SCALE DRAWING
CENTER CONTACTS: COPPER ALLOY SHEET SCALE: 3:2
OUT CONTACTS:
-MOSP/MDSJ/-01SP/-01BJ/-01SB: COPPER ALLOY
-24SP/-24SJ/-92SP/-92SJ/-00BC/
-00BF/-00BL/-00BS: STAINLESS STEEL
INSULATORS:
-MOSP/MDSJ/-01SP/-01BJ/-01SB/-00BC/
-00BF/-00BL/-00BS: VIRGIN PTFE FLUOROCARBON
-24SP/-24SJ/-92SP/92SJ: ULTEM

samtec
520 PARK EAST BLVD. NEW ALBANY, IN 47150
PHONE: 812-944-6733 FAX: 812-948-5047
e-Mail info@SAMTEC.com code 55322

DESCRIPTION: RF23C CABLE ASSEMBLY

DWG. NO. RF23C-XXXX-XXXX-XXXX

BY: PETER D 3/7/2017 SHEET 1 OF 8

TABLE 2							
END OPTION	SERIES	GENDER	FINISH			CONNECTOR KIT P/N (PCI P/N)	FIGURE
			CENTER CONTACT	OUTER CONTACT	CABLE BODY		
-24SP	2.40 MM	PLUG	50µ" GOLD	PASSIVATED	PASSIVATED	PRF24-P-C-EP-23C-SS (4181)	SHT 3, FIG 2
-24SJ	2.40 MM	JACK	50µ" GOLD	PASSIVATED	PASSIVATED	PRF24-J-C-EP-23C-SS (4182)	SHT 3, FIG 3
-92SP	2.92 MM	PLUG	30µ" GOLD	PASSIVATED	PASSIVATED	292-P-C-HP-ST-CU3 (N/A)	SHT 4, FIG 4
-92SJ	2.92 MM	JACK	30µ" GOLD	PASSIVATED	PASSIVATED	292-J-C-HP-ST-CU3 (N/A)	SHT 4, FIG 5
-M0SP	SMPM	PLUG, FULL DETENT	50µ" GOLD	50µ" GOLD	3µ" GOLD	PRFM0-P-C-EE-23C-SD (N/A)	SHT 5, FIG 6
-M0SJ	SMPM	JACK	50µ" GOLD	50µ" GOLD	3µ" GOLD	PRFM0-J-C-EE-23C-SD (N/A)	SHT 5, FIG 7
-01SP	SMA	PLUG	50µ" GOLD	10µ" GOLD	10µ" GOLD	PRF01-P-C-EG-23C-SD (N/A)	SHT 6, FIG 9
-01BJ	SMA	BULKHEAD JACK	50µ" GOLD	10µ" GOLD	10µ" GOLD	PRF01-J-C-EG-23C-BD (N/A)	SHT 6, FIG 10
-01SB	SMA	SEALED BULKHEAD JACK	50µ" GOLD	10µ" GOLD	10µ" GOLD	PRF01-J-C-EG-23C-BD-1 (N/A)	SHT 7, FIG 11
*-00SJ	SMP	JACK	50µ" GOLD	50µ" GOLD	50µ" GOLD	PRF00-J-C-EE-23C-SD (N/A)	SHT 7, FIG 12
*-00MJ	SMP	R/A JACK	50µ" GOLD	50µ" GOLD	50µ" GOLD	PRF00-J-C-EE-23C-RD (N/A)	SHT 8, FIG 13
*-00BC	SMP	BULKHEAD PLUG	50µ" GOLD	10µ" GOLD	10µ" GOLD	PRF00-PC-C-EG-23C-BD (N/A)	SHT 8, FIG 14
*-00BF	SMP	BULKHEAD PLUG	50µ" GOLD	10µ" GOLD	10µ" GOLD	PRF00-PF-C-EG-23C-BD (N/A)	SHT 8, FIG 14
*-00BL	SMP	BULKHEAD PLUG	50µ" GOLD	10µ" GOLD	10µ" GOLD	PRF00-PL-C-EG-23C-BD (N/A)	SHT 8, FIG 14
*-00BS	SMP	BULKHEAD PLUG	50µ" GOLD	10µ" GOLD	10µ" GOLD	PRF00-PS-C-EG-23C-BD (N/A)	SHT 8, FIG 14
**SING	SINGLE ENDED	-	-	-	-	-	-
**XXXXX	STRIPPED & TINNED	-	-	-	-	-	SHT 1, FIG 8

** = END 2 OPTION ONLY
* = NOT RELEASED

TABLE 3					
END OPTION	MAXIMUM VSWR	MAXIMUM RETURN LOSS	END OPTION INSERTION LOSS	FREQUENCY	PROTECTIVE CAP COLOR
-24SP	1.40:1	15.56 dB	0.5	DC TO 50 GHz	GREEN
-24SJ	1.40:1	15.56 dB	0.5	DC TO 50 GHz	GREEN
-92SP	1.40:1	15.56 dB	0.41	DC TO 40 GHz	YELLOW
-92SJ	1.40:1	15.56 dB	0.41	DC TO 40 GHz	YELLOW
-M0SP	1.20:1	20.83 dB	0.5	DC TO 26.5 GHz	GRAY
	1.40:1	15.56 dB		26.5 GHz TO 50 GHz	
-M0SJ	1.20:1	20.83 dB	0.5	DC TO 26.5 GHz	GRAY
	1.40:1	15.56 dB		26.5 GHz TO 50 GHz	
-01SP	1.30:1	17.7 dB	0.23	DC TO 26.5 GHz	BROWN
-01BJ	1.30:1	17.7 dB	0.23	DC TO 26.5 GHz	BROWN
-01SB	1.30:1	17.7 dB	0.23	DC TO 26.5 GHz	BROWN
*-00SJ	1.25:1	19.09 dB	0.5	DC TO 26.5 GHz	WHITE
	1.50:1	13.98 dB		26.5 GHz TO 40 GHz	
*-00MJ	1.25:1	19.09 dB	0.5	DC TO 26.5 GHz	WHITE
*-00BC	1.25:1	19.09 dB	0.5	DC TO 26.5 GHz	GRAY
	1.50:1	13.98 dB		26.5 GHz TO 40 GHz	
*-00BF	1.25:1	19.09 dB	0.5	DC TO 26.5 GHz	GRAY
	1.50:1	13.98 dB		26.5 GHz TO 40 GHz	
*-00BL	1.25:1	19.09 dB	0.5	DC TO 26.5 GHz	GRAY
	1.50:1	13.98 dB		26.5 GHz TO 40 GHz	
*-00BS	1.25:1	19.09 dB	0.5	DC TO 26.5 GHz	GRAY
	1.50:1	13.98 dB		26.5 GHz TO 40 GHz	

IL Max [dB] for cable assembly:
= {19.65*SQRT(Freq[GHz])+1.16*Freq[GHz]}*OAL[mm]/30480+End Option IL#1(See Table 3)+End Option IL#2(See Table 3)
* = NOT RELEASED

<p>PROPRIETARY NOTE</p> <p>THIS DOCUMENT CONTAINS CONFIDENTIAL AND PROPRIETARY INFORMATION AND ALL DESIGN, MANUFACTURING, REPRODUCTION, USE, PATENT RIGHTS AND SALES RIGHTS ARE EXPRESSLY RESERVED BY SAMTEC, INC. THIS DOCUMENT SHALL NOT BE DISCLOSED, IN WHOLE OR PART, TO ANY UNAUTHORIZED PERSON OR ENTITY NOR REPRODUCED, TRANSFERRED OR INCORPORATED IN ANY OTHER PROJECT IN ANY MANNER WITHOUT THE EXPRESS WRITTEN CONSENT OF SAMTEC, INC.</p>	 520 PARK EAST BLVD, NEW ALBANY, IN 47150 PHONE: 812-944-6733 FAX: 812-948-5047 e-Mail info@SAMTEC.com code 55322
<p>DO NOT SCALE DRAWING</p>	<p>DESCRIPTION: RF23C CABLE ASSEMBLY</p>
<p>SHEET SCALE: 3:2</p>	<p>DWG. NO. RF23C-XXXX-XXXX-XXXX</p>
<p>F:\DWG\MISC\MKTG\RF23C-XXXX-XXXX-XXXX-MKT.SLDDRW</p>	<p>BY: PETER D 3/7/2017 SHEET 2 OF 8</p>

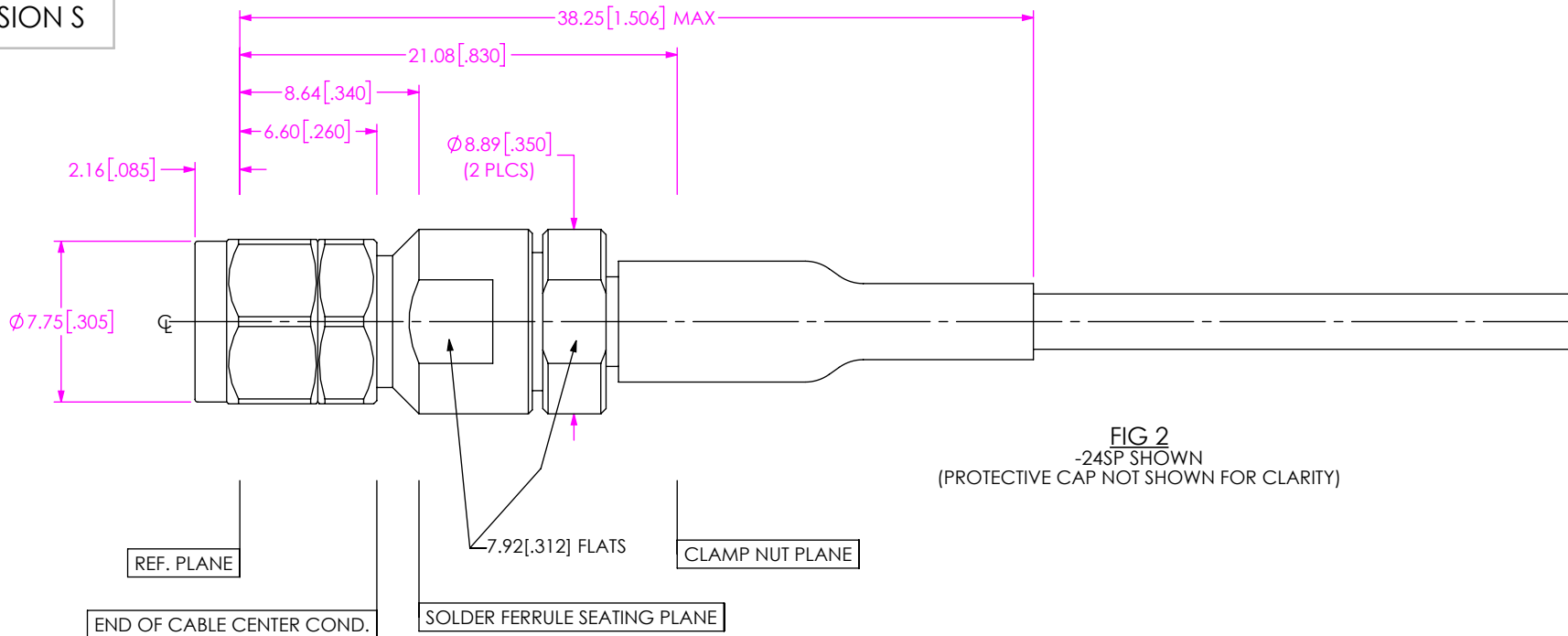

FIG 2
-24SP SHOWN
(PROTECTIVE CAP NOT SHOWN FOR CLARITY)

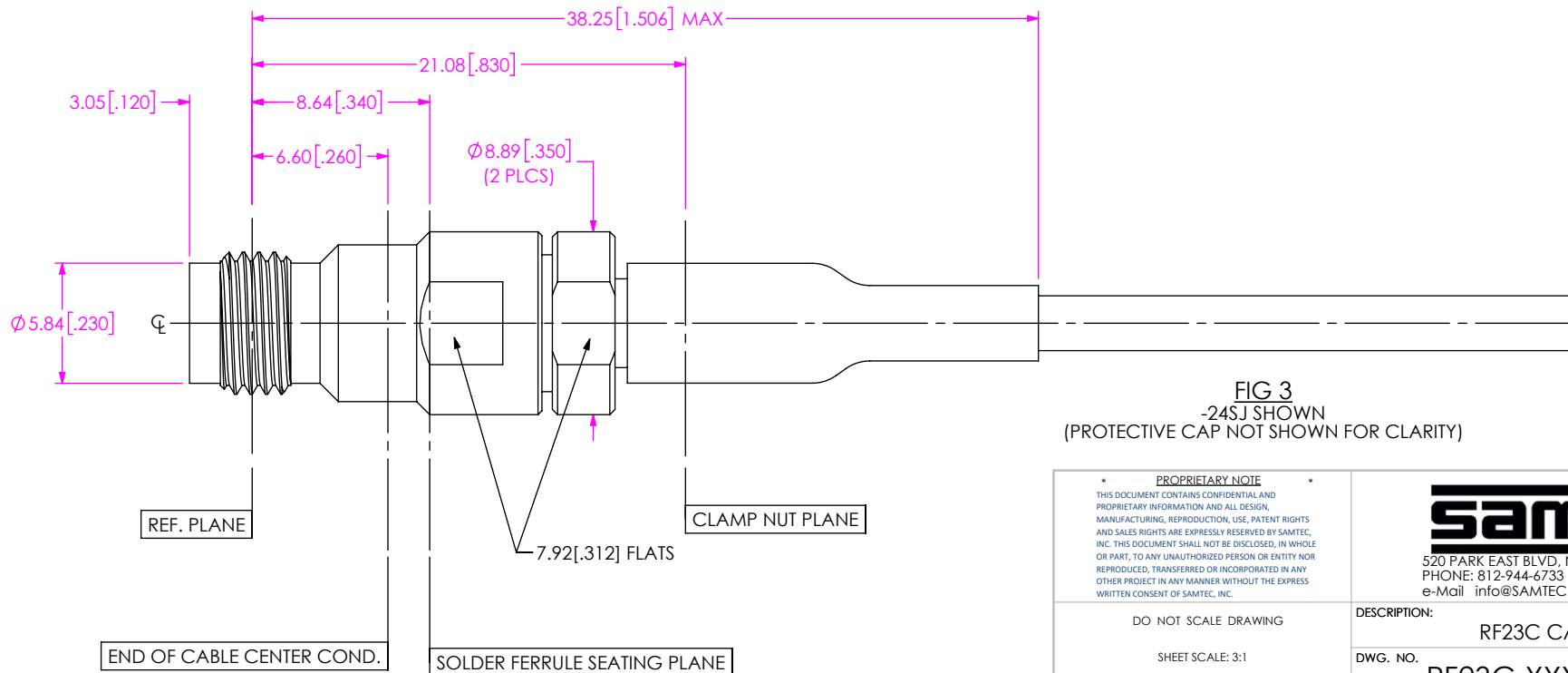

FIG 3
-24SJ SHOWN
(PROTECTIVE CAP NOT SHOWN FOR CLARITY)

PROPRIETARY NOTE
THIS DOCUMENT CONTAINS CONFIDENTIAL AND PROPRIETARY INFORMATION AND ALL DESIGN, MANUFACTURING, REPRODUCTION, USE, PATENT RIGHTS AND SALES RIGHTS ARE EXPRESSLY RESERVED BY SAMTEC, INC. THIS DOCUMENT SHALL NOT BE DISCLOSED, IN WHOLE OR PART, TO ANY UNAUTHORIZED PERSON OR ENTITY NOR REPRODUCED, TRANSFERRED OR INCORPORATED IN ANY OTHER PROJECT IN ANY MANNER WITHOUT THE EXPRESS WRITTEN CONSENT OF SAMTEC, INC.

samtec

520 PARK EAST BLVD., NEW ALBANY, IN 47150
PHONE: 812-944-6733 FAX: 812-948-5047
e-Mail info@SAMTEC.com code 55322

DO NOT SCALE DRAWING

SHEET SCALE: 3:1

DESCRIPTION: RF23C CABLE ASSEMBLY

DWG. NO. RF23C-XXXX-XXXX-XXXX

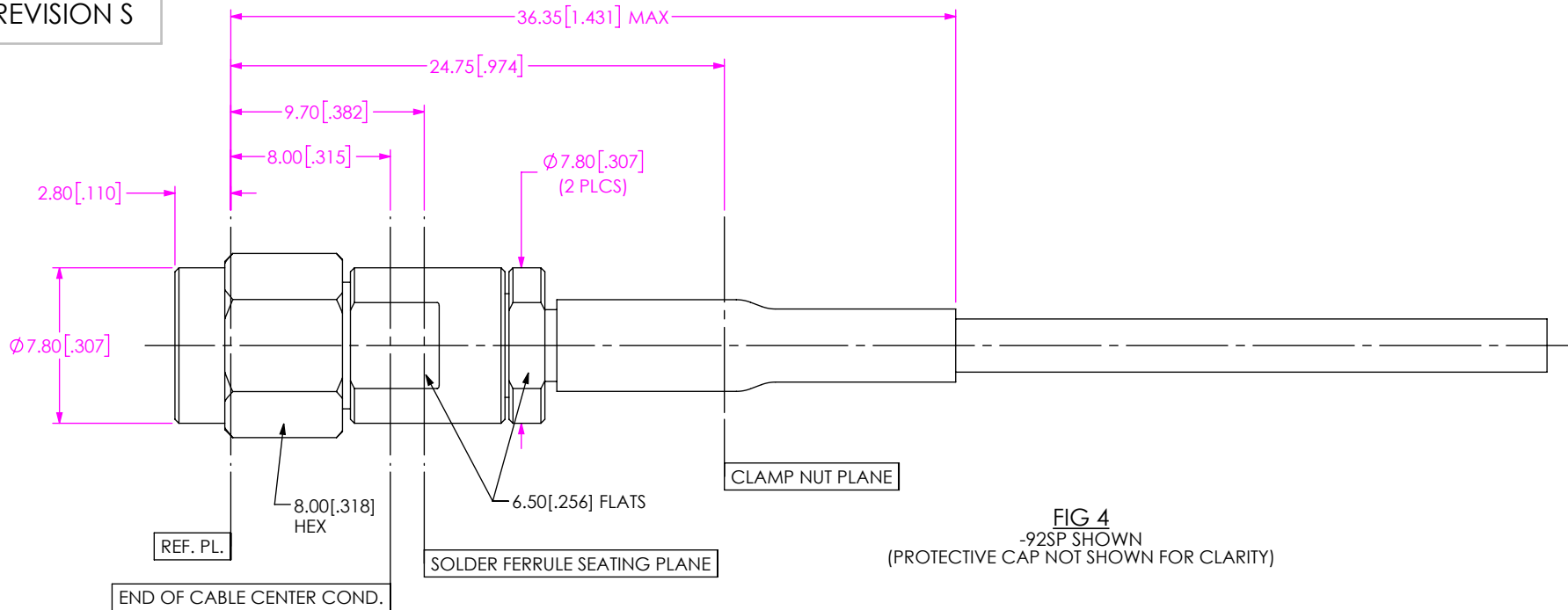

FIG 4
-92SP SHOWN
(PROTECTIVE CAP NOT SHOWN FOR CLARITY)

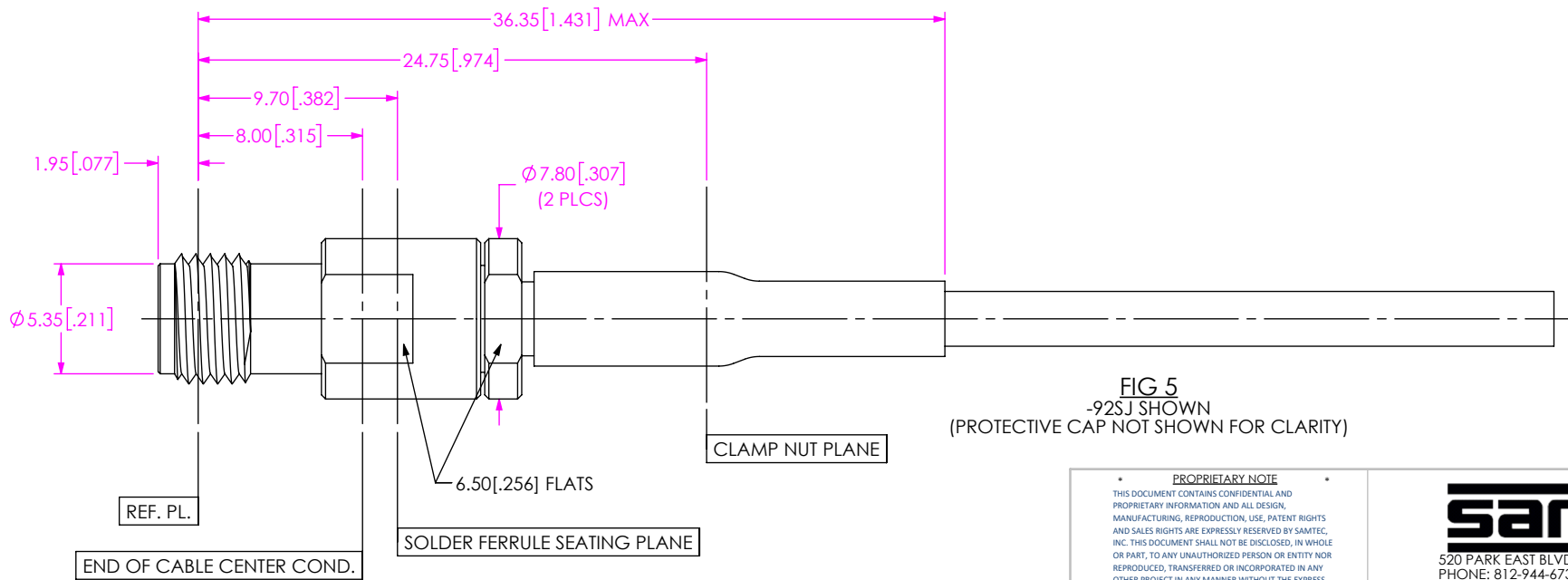

FIG 5
-92SJ SHOWN
(PROTECTIVE CAP NOT SHOWN FOR CLARITY)

PROPRIETARY NOTE
THIS DOCUMENT CONTAINS CONFIDENTIAL AND PROPRIETARY INFORMATION AND ALL DESIGN, MANUFACTURING, REPRODUCTION, USE, PATENT RIGHTS AND SALES RIGHTS ARE EXPRESSLY RESERVED BY SAMTEC, INC. THIS DOCUMENT SHALL NOT BE DISCLOSED, IN WHOLE OR PART, TO ANY UNAUTHORIZED PERSON OR ENTITY NOR REPRODUCED, TRANSFERRED OR INCORPORATED IN ANY OTHER PROJECT IN ANY MANNER WITHOUT THE EXPRESS WRITTEN CONSENT OF SAMTEC, INC.

samtec

520 PARK EAST BLVD, NEW ALBANY, IN 47150
PHONE: 812-944-6733 FAX: 812-948-5047
e-Mail info@SAMTEC.com code 55322

DO NOT SCALE DRAWING

SHEET SCALE: 3:1

DESCRIPTION: RF23C CABLE ASSEMBLY

DWG. NO. RF23C-XXXX-XXXX-XXXX

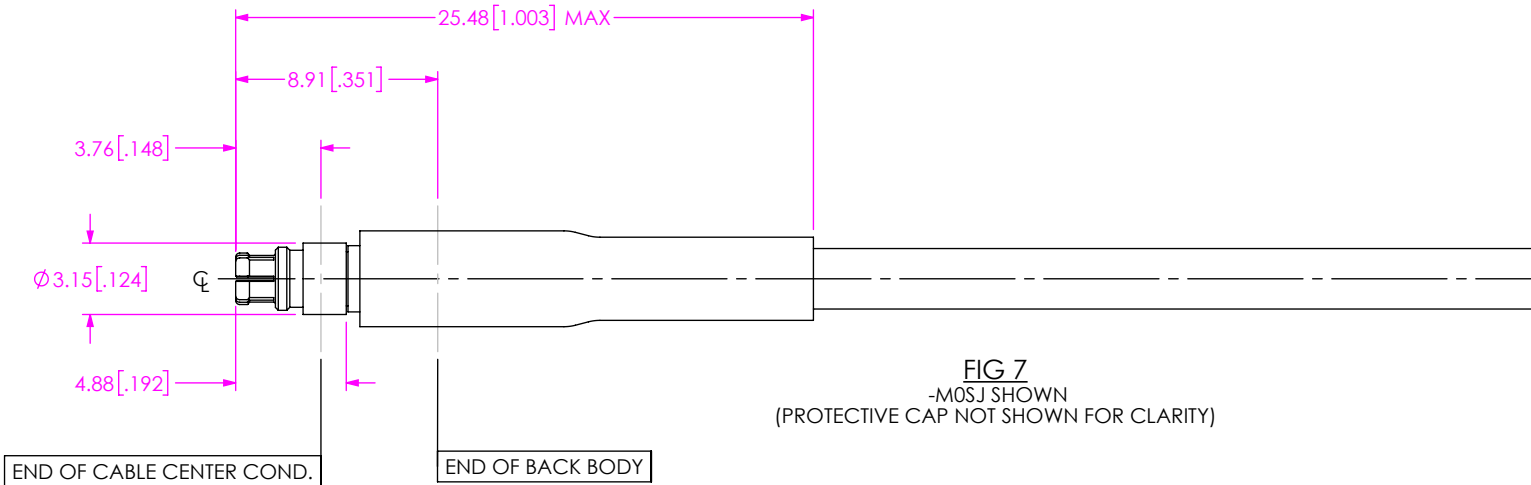
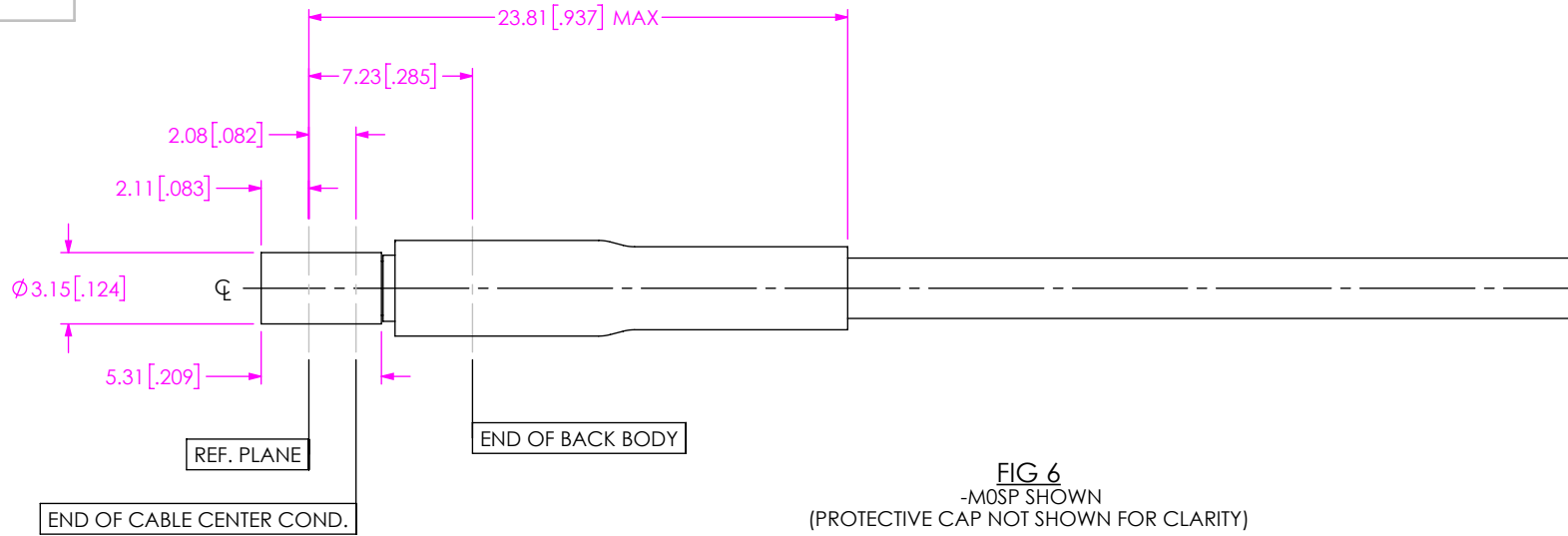

PROPRIETARY NOTE
THIS DOCUMENT CONTAINS CONFIDENTIAL AND PROPRIETARY INFORMATION AND ALL DESIGN, MANUFACTURING, REPRODUCTION, USE, PATENT RIGHTS AND SALES RIGHTS ARE EXPRESSLY RESERVED BY SAMTEC, INC. THIS DOCUMENT SHALL NOT BE DISCLOSED, IN WHOLE OR PART, TO ANY UNAUTHORIZED PERSON OR ENTITY NOR REPRODUCED, TRANSFERRED OR INCORPORATED IN ANY OTHER PROJECT IN ANY MANNER WITHOUT THE EXPRESS WRITTEN CONSENT OF SAMTEC, INC.

samtec
520 PARK EAST BLVD, NEW ALBANY, IN 47150
PHONE: 812-944-6733 FAX: 812-948-5047
e-Mail info@SAMTEC.com code 55322

DO NOT SCALE DRAWING
SHEET SCALE: 3:1

DESCRIPTION: RF23C CABLE ASSEMBLY
DWG. NO. RF23C-XXXX-XXXX-XXXX

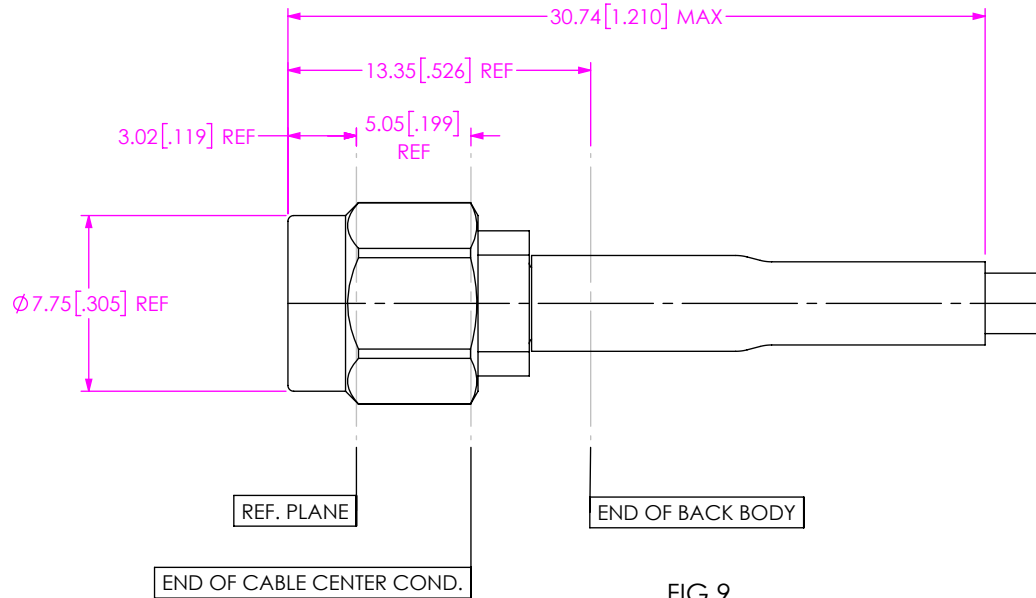

FIG 9
-01SP SHOWN
(PROTECTIVE CAP NOT SHOWN FOR CLARITY)

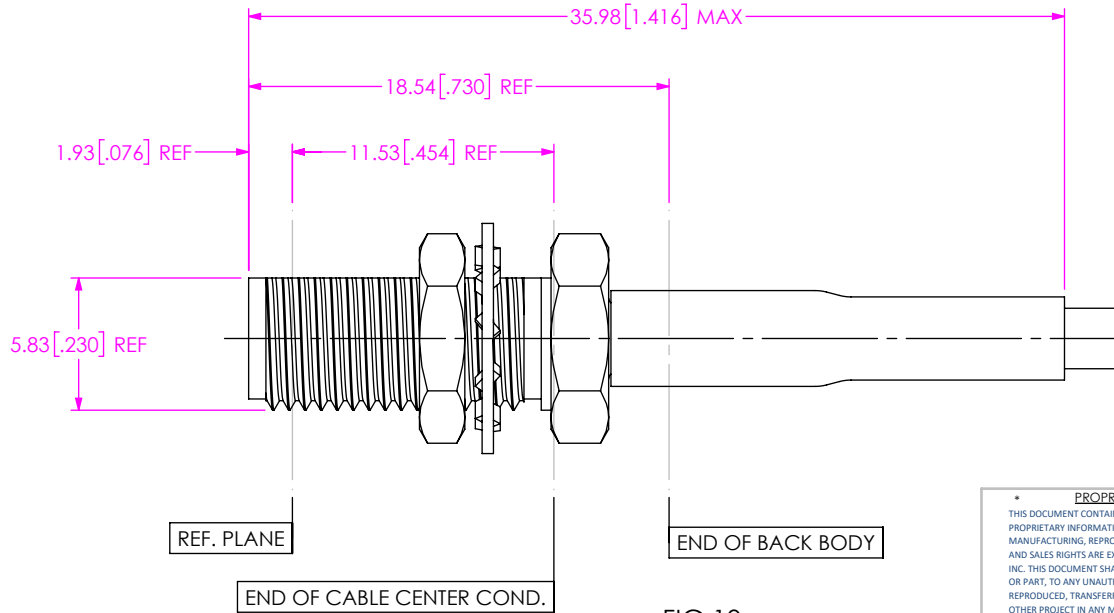
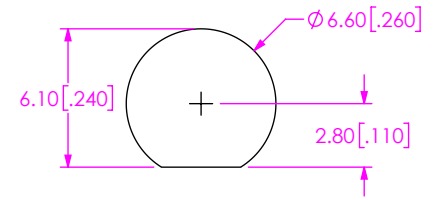

FIG 10
-01BJ SHOWN
(PROTECTIVE CAP NOT SHOWN FOR CLARITY)



RECOMMENDED PANEL LAYOUT

PROPRIETARY NOTE
THIS DOCUMENT CONTAINS CONFIDENTIAL AND PROPRIETARY INFORMATION AND ALL DESIGN, MANUFACTURING, REPRODUCTION, USE, PATENT RIGHTS AND SALES RIGHTS ARE EXPRESSLY RESERVED BY SAMTEC, INC. THIS DOCUMENT SHALL NOT BE DISCLOSED, IN WHOLE OR PART, TO ANY UNAUTHORIZED PERSON OR ENTITY NOR REPRODUCED, TRANSFERRED OR INCORPORATED IN ANY OTHER PROJECT IN ANY MANNER WITHOUT THE EXPRESS WRITTEN CONSENT OF SAMTEC, INC.

DO NOT SCALE DRAWING
SHEET SCALE: 3:1



520 PARK EAST BLVD, NEW ALBANY, IN 47150
PHONE: 812-944-6733 FAX: 812-948-5047
e-Mail info@SAMTEC.com code 55322

DESCRIPTION: RF23C CABLE ASSEMBLY
DWG. NO. RF23C-XXXX-XXXX-XXXX

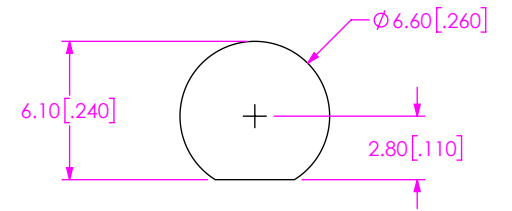
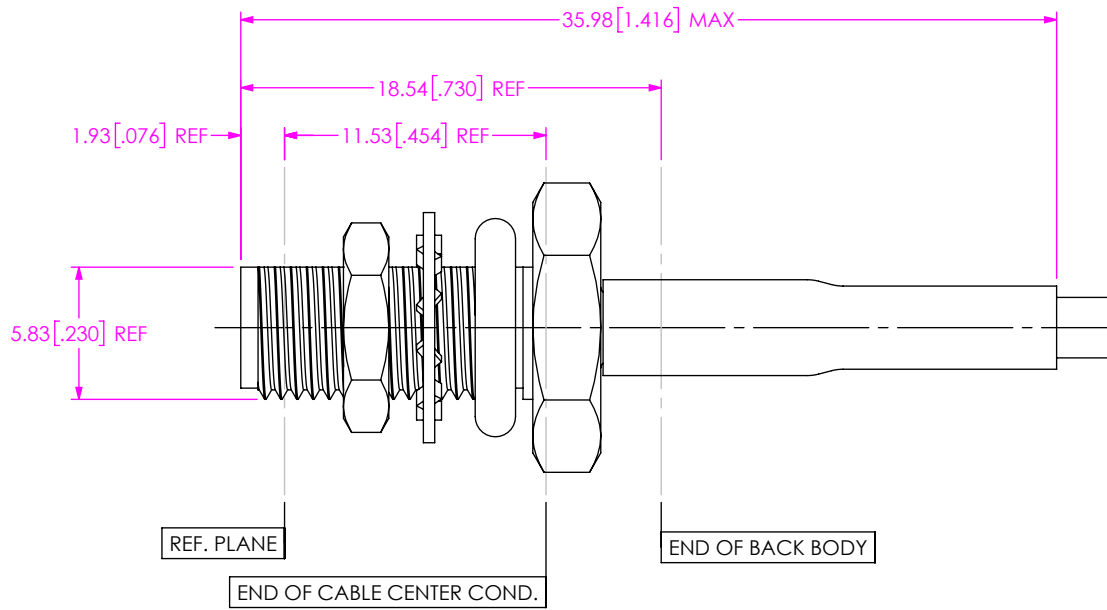

RECOMMENDED PANEL LAYOUT

FIG 11
-01SB SHOWN
(PROTECTIVE CAP NOT SHOWN FOR CLARITY)

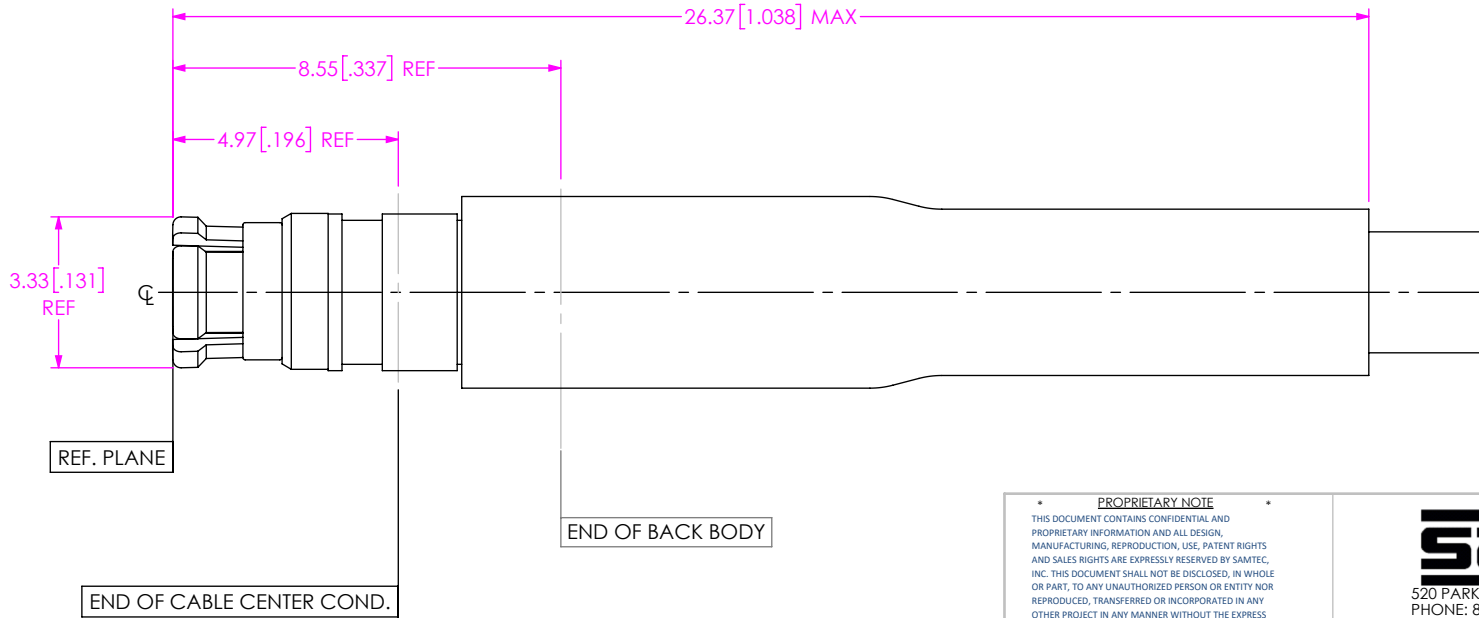

FIG 12
-00SJ SHOWN
(PROTECTIVE CAP NOT SHOWN FOR CLARITY)

PROPRIETARY NOTE
THIS DOCUMENT CONTAINS CONFIDENTIAL AND PROPRIETARY INFORMATION AND ALL DESIGN, MANUFACTURING, REPRODUCTION, USE, PATENT RIGHTS AND SALES RIGHTS ARE EXPRESSLY RESERVED BY SAMTEC, INC. THIS DOCUMENT SHALL NOT BE DISCLOSED, IN WHOLE OR PART, TO ANY UNAUTHORIZED PERSON OR ENTITY NOR REPRODUCED, TRANSFERRED OR INCORPORATED IN ANY OTHER PROJECT IN ANY MANNER WITHOUT THE EXPRESS WRITTEN CONSENT OF SAMTEC, INC.



520 PARK EAST BLVD, NEW ALBANY, IN 47150
PHONE: 812-944-6733 FAX: 812-948-5047
e-Mail info@SAMTEC.com code 55322

DO NOT SCALE DRAWING

SHEET SCALE: 3:1

DESCRIPTION: RF23C CABLE ASSEMBLY

DWG. NO. RF23C-XXXX-XXXX-XXXX

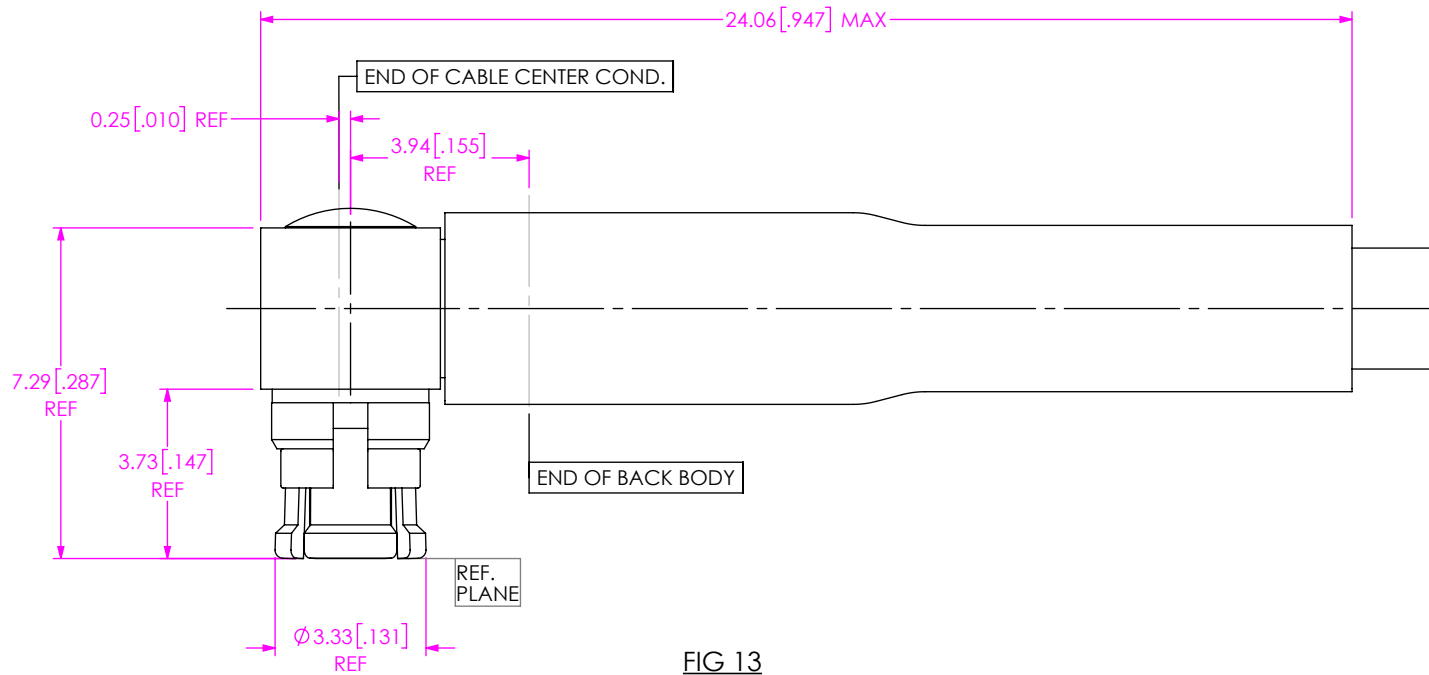

FIG 13
-00MJ SHOWN
(PROTECTIVE CAP NOT SHOWN FOR CLARITY)

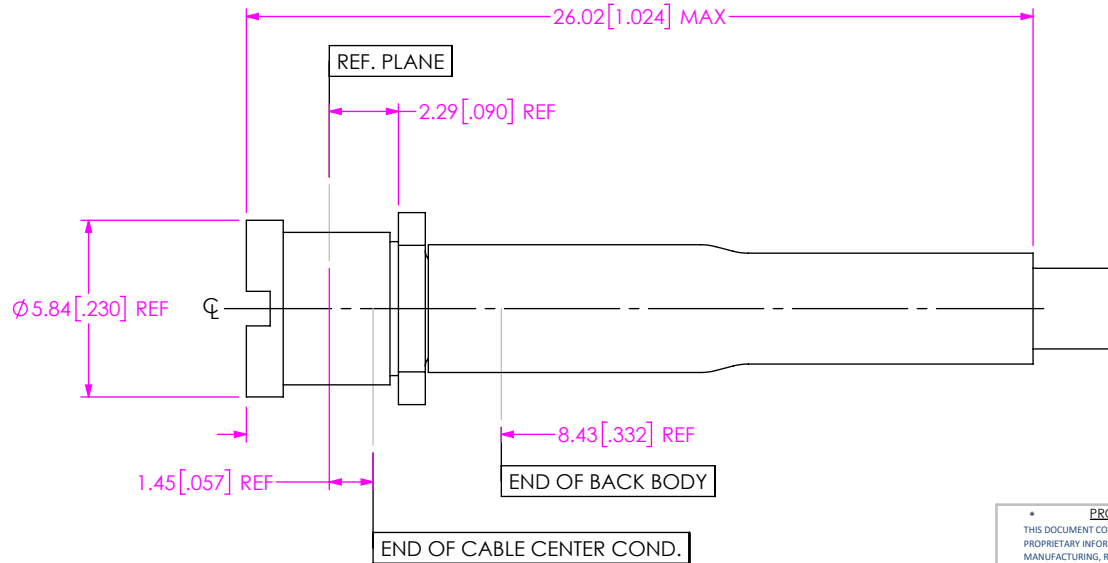
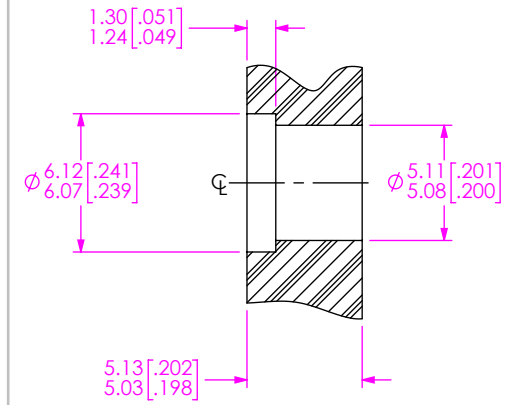

FIG 14
-00BC, -00BF, -00BL, -00BS SHOWN
(PROTECTIVE CAP NOT SHOWN FOR CLARITY)



RECOMMENDED PANEL LAYOUT

PROPRIETARY NOTE
THIS DOCUMENT CONTAINS CONFIDENTIAL AND PROPRIETARY INFORMATION AND ALL DESIGN, MANUFACTURING, REPRODUCTION, USE, PATENT RIGHTS AND SALES RIGHTS ARE EXPRESSLY RESERVED BY SAMTEC, INC. THIS DOCUMENT SHALL NOT BE DISCLOSED, IN WHOLE OR PART, TO ANY UNAUTHORIZED PERSON OR ENTITY NOR REPRODUCED, TRANSFERRED OR INCORPORATED IN ANY OTHER PROJECT IN ANY MANNER WITHOUT THE EXPRESS WRITTEN CONSENT OF SAMTEC, INC.

DO NOT SCALE DRAWING
SHEET SCALE: 3:1

samtec

520 PARK EAST BLVD, NEW ALBANY, IN 47150
PHONE: 812-944-6733 FAX: 812-948-5047
e-Mail info@SAMTEC.com code 55322

DESCRIPTION: RF23C CABLE ASSEMBLY

DWG. NO. RF23C-XXXX-XXXX-XXXX