

■ Features

- Low profile construction and miniature size.
- Magnetic shielded construction.
- High current saturation.
- Operating temperature: -40°C ~ +125°C.
- RoHS compliant

■ Applications

- For small DC/DC converter(HDD,DVC,DSC,PDA,LCD display etc.).
- Car navigation systems,telecom base stations.
- VR,AR,LED lighting.

■ Product Identification

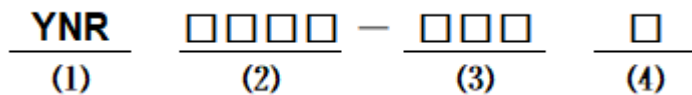

(1) : Type

(2) : Dimensions

(3) : Inductance value

(4) : Inductance Tolerance; N=±30%,M=±20%, K=±10%

■ Shapes and Dimensions (Unit: mm)

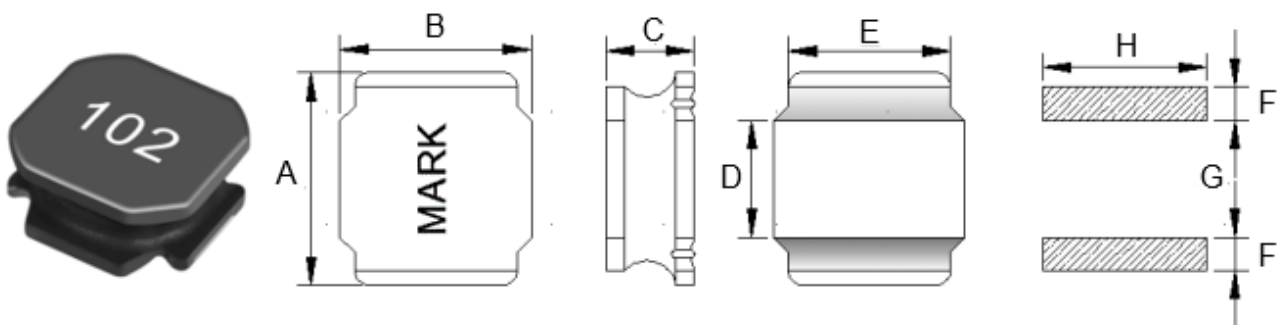

TYPE	A	B	C Max.	D Typ.	E Ref.	F Ref.	G Ref.	H Ref.
YNR6045	6.0±0.3	6.0±0.3	4.5	2.9	5.7	1.7	2.8	5.7

■ Electrical Characteristics List

Part Number	Inductance (uH) @100KHz	DC Resistance (Ω)		Heat Rating Current (A)	Saturation Current (A)
		Typ.	Max.		
YNR6045-332M	3300±20%	16.54	21.50	0.15	0.17

- ※ The saturation current value is the DC current value having inductance decrease down to 30%. (at 20°C)
- ※ The temperature rise current value is the DC current value having temperature increase up to 40°C. (at 20°C)
- ※ The rated current is the DC current value that satisfies both of current value saturation current value and temperature rise current value.

■ Taping Dimensions(Unit:mm)

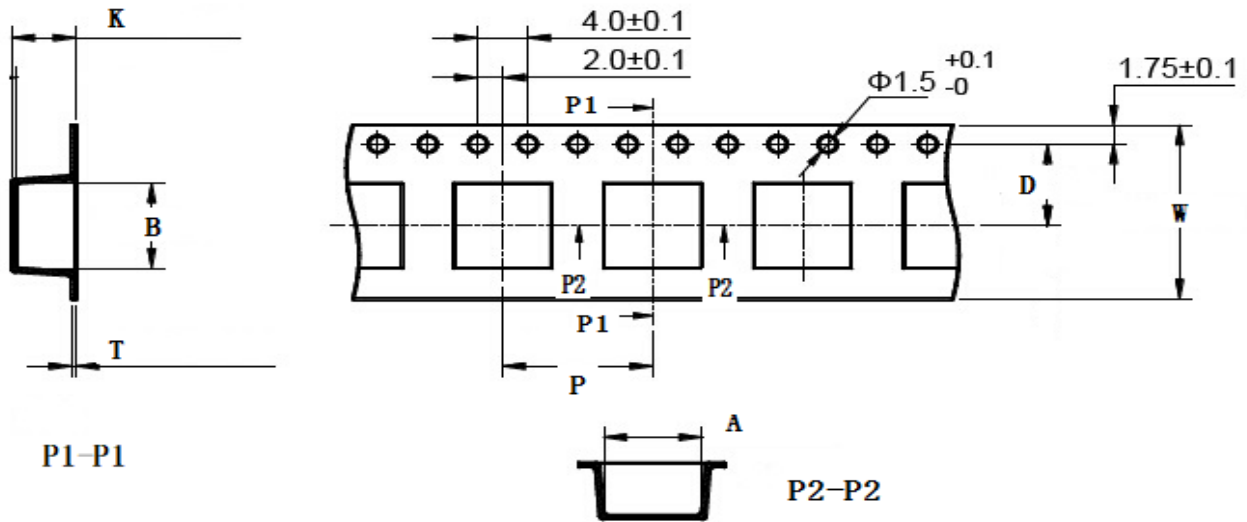

TYPE	Chip Thickness	W	A	B	D	P	K Max	T Max	MPQ
YNR6045	4.50	16.0	6.40	6.40	7.50	8.00	4.70	0.40	1500

■ Reel Dimensions(Unit:mm)

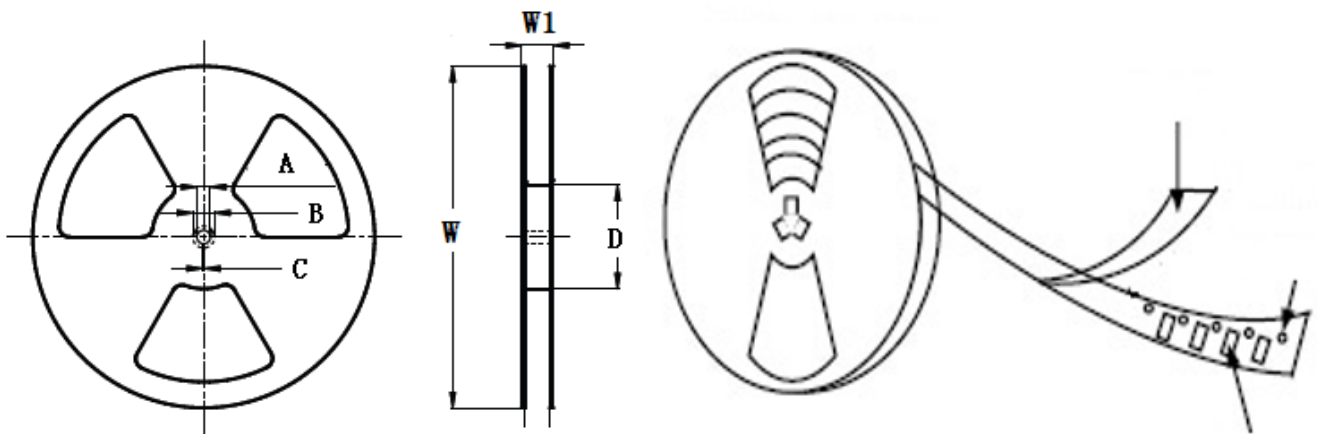

TYPE	W	W1	A	B	C	D
YNR6045	330±2.0	16.5±1.50	13.0±0.50	21.0±0.80	2.0±0.50	100 Min

Direction of rolling

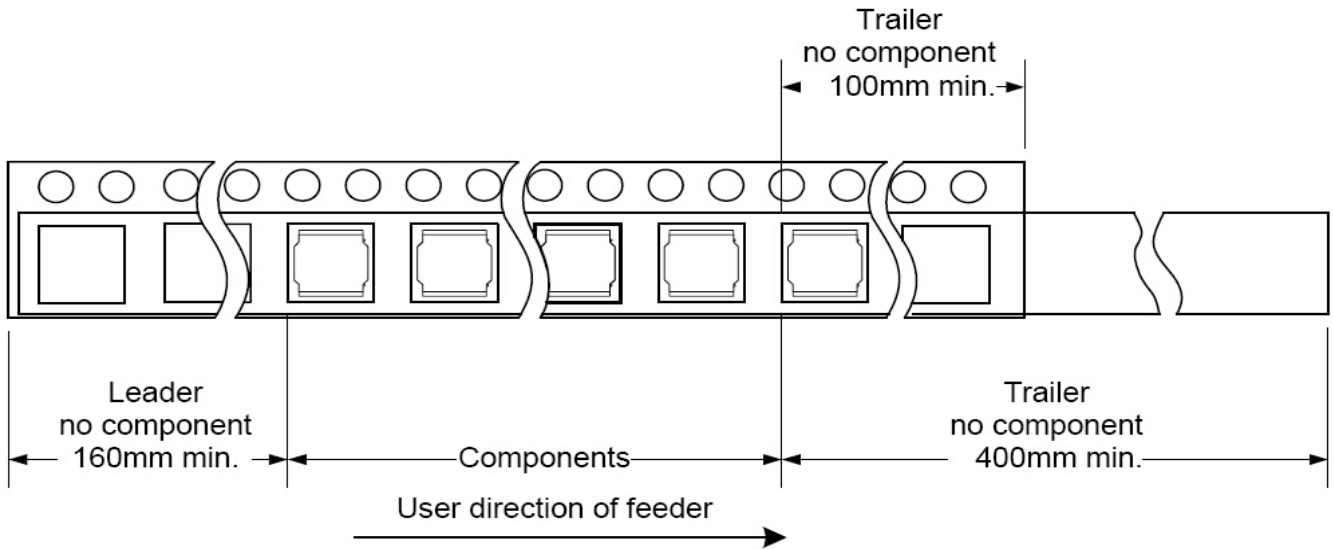

Cover tape peel off condition

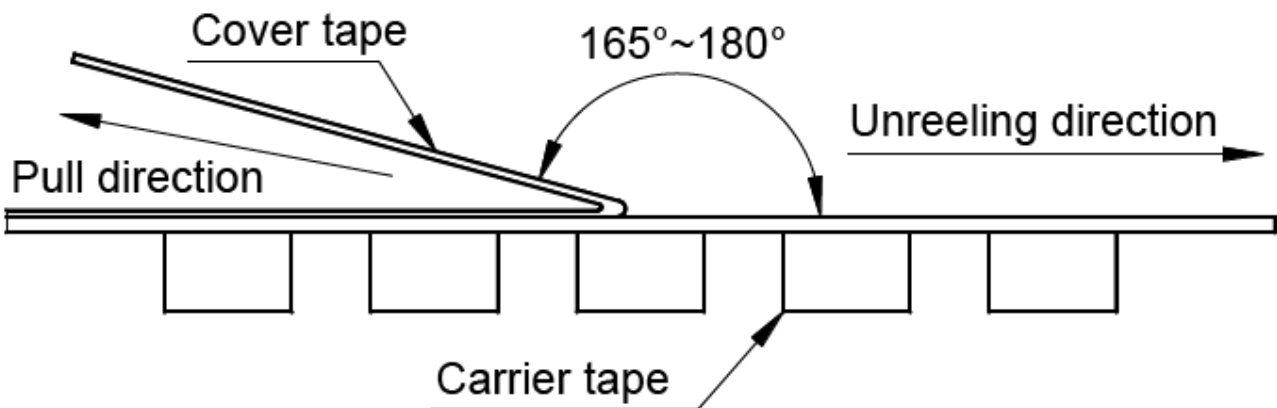

Cover tape peel force shall be 0.1N to 1.3N.

Reference peel speed 300±10mm/min.