

## 产品特点 Product Features

# PLASTIC THERMISTOR NTC

- 1.MF72系列产品为径向引线树脂涂装型
- 2.体积小，功率大，抑制浪涌电流能力强
- 3.反应速度快
- 4.材料常数（B值）大，残余电阻小
- 5.寿命长，可靠性高
- 6.产品规格齐全，工作范围宽
- 7.工作温度-40~ +175℃

- 1.MF72 series in the form of radial resin coated form
- 2.Small dimension, powerful, strong in inrush current limiting
- 3.Fast response
- 4.Large material constant, lower residue resistance
- 5.Long life, high reliability
- 6.Complete part, wide operation range
- 7.Operating temperature -40~+175℃

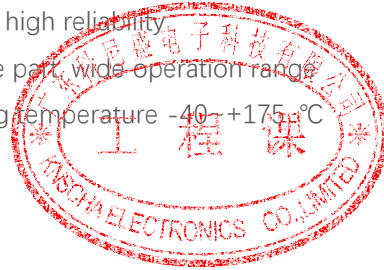

## 应用范围 Application scope

- 1.转换电源、开关电源、UPS电源
- 2.电子节能灯、电子镇流器
- 3.电子线路、电源线路等

1. Conversion power, switch mode power supply, UPS power
2. Energy saving lights, ballast
3. Electronic circuit, power supply circuit

## 产品型号说明 Product Model Description

KNSCHA	3220	N	2R5	M	3R0
品牌 Logo	尺寸 Size	Negative Temperature Coefficient NTC负温度系数	Rated Zero-Power Resistance 额定零功率电阻值	Accuracy Error 精度误差	Max. Steady State Current 最大稳态电流
	2220(5750) 3220(8050) 3225(8060) 4032(1008)		2R5=2.5Ω  100=10Ω  101=100Ω	K: 10%  M: 20%	3R0: 3A  5R0: 5A  100: 10A

## 温度特性 Temperature

Parameter	Value	Unit
Operating temperature工作温度	-40 ~ +175	℃
Storage temperature存储温度	-10 ~ +40	℃
thermal time constant	≤18	S
Insulation resistance	≥6	mW/℃

## 主要技术参数 Main technical parameters

尺寸型号Size: 3220

P/N	R <sub>25</sub> (Ω) Resistance	Maximum steady-state current (A)	Residual resistance (Ω)	Resistance B <sub>25/85</sub> (K)	Thermal time constant (s)	Dissipation Coefficient (mW/°C)	Operation Temperature (°C)
	2.5	3	0.195	2700	≤30	≥9	-40 ~ 175
	3	3	0.206	2700			
	4	2	0.246	2700			
192NTC0004	5	2	0.286	2700			
	6	2	0.436	2700			
	7	2	0.585	2700			
	8	1	0.735	2800			
	10	1	0.789	2800			
	12	0.7	1.180	2800			
	15	0.7	1.465	3000			
	16	0.7	1.560	3000			
	18	0.7	1.774	3000			
	20	0.6	1.988	3000			
	22	0.6	1.950	3000			
	25	0.5	2.609	3000			
	30	0.5	3.706	3000			

## 电性测试 Electrical Test

序号 No.	项目 Items	测试方法及备注 Test Methods and Remarks
1	25℃ 零功率电阻值 Nominal Zero-Power Resistance at 25℃ (R25)	环境温度 Ambient temperature: 25±0.05℃ 测试功率 Measuring electric power: ≤ 0.1mW
2	B 值常数 Nominal B Constant	分别在环境温度 25±0.05℃, 50±0.05℃ 或 85±0.05℃ 下测量电阻值。 Measure the resistance at the ambient temperature of 25±0.05℃, 50±0.05℃ or 85±0.05℃. $B(25-50^{\circ}\text{C}) = \frac{1}{1/T_{25} - 1/T_{50}} \ln \frac{R_{25}}{R_{50}} \quad B(25-85^{\circ}\text{C}) = \frac{1}{1/T_{25} - 1/T_{85}} \ln \frac{R_{25}}{R_{85}}$ T: 绝对温度 (K) Absolute temperature (K)
3	热时间常数 Thermal Time Constant	在零功率条件下, 当热敏电阻的环境温度发生急剧变化时, 热敏电阻元件产生最初温度 T <sub>0</sub> 与最终温度 T <sub>1</sub> 两者温度差的 63.2% 的温度变化所需要的时间, 通常以秒 (s) 表示。 The total time for the temperature of the thermistor to change by 63.2% of the difference from ambient temperature T <sub>0</sub> (°C) to T <sub>1</sub> (°C) by the drastic change of the power applied to thermistor from Non-zero Power to Zero-Power state, normally expressed in second (S).
4	耗散系数 Dissipation Factor	在一定环境温度下, NTC 热敏电阻通过自身发热使其温度升高 1℃ 时所需要的功率, 通常以 mW/°C 表示。可由下面公式计算: The required power which makes the NTC thermistor body temperature raise 1℃ through self-heated, normally expressed in milliwatts per degree Celsius (mW/°C). It can be calculated by the following formula: $\delta = \frac{W}{T - T_0}$
5	额定功率 Rated Power	在环境温度 25℃ 下因自身发热使表面温度升高 100℃ 所需要的功率。 The necessary electric power makes thermistor's temperature rise 100℃ by self-heating at ambient temperature 25℃ .
6	允许工作电流 Permissible operating current	在静止空气中通过自身发热使其升温为 1℃ 的电流。 The current that keep body temperature of chip NTC on the PC board in still air rising 1℃ by self-heating.

## 尺寸图 Dimensional drawings

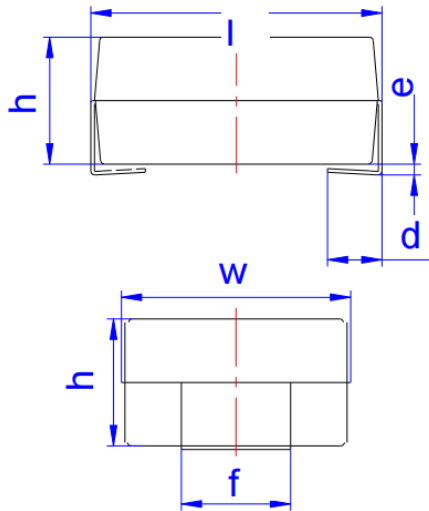

Ref.	Dimensions					
	Millimeters			Inches		
	Min.	Typ.	Max.	Min.	Typ.	Max.
l	7.7		8.3	0.303		0.327
w	6.0		6.6	0.236		0.260
h	3.3		4.0	0.122		0.150
d	1.2		1.8	0.047		0.071
e	0		0.3	0		0.012
f	2.7		3.3	0.106		0.130

## 推荐焊盘布局 Recommended solder pad layout

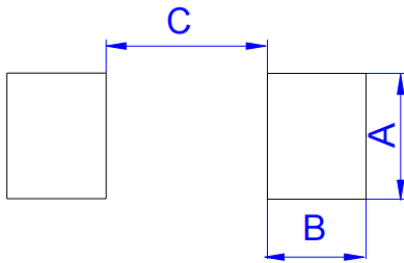

Ref.	Dimensions					
	Millimeters			Inches		
	Min.	Typ.	Max.	Min.	Typ.	Max.
A		3.5			0.138	
B		2.8			0.110	
C		4.5			0.177	

## 焊接指南 Dimensional drawings

建议使用温和的非活性焊剂进行焊接，并适当清洁PCB。

The usage of mild, non-activated fluxes for soldering is recommended, as well as proper cleaning of the PCB.

根据JEDEC J-STD-020C，这些部件适用于回流焊

The components are suitable for reflow soldering per JEDEC J-STD-020C.

### 建议焊接条件 Recommended Soldering Technologies

#### 回流焊 Re-flowing Profile

温升：1~2°C/sec.

1~2°C/sec. Ramp

预热：150~190°C/90±30 sec.

Pre-heating: 150~190°C/90±30 sec.

大于 240°C时间：20~40sec

Time above 240°C: 20~40 sec.

峰值温度：最高 260°C/10 sec.

Peak temperature: 260°C Max./10 sec.

焊锡：Sn/3.0Ag/0.5Cu

Solder paste: Sn/3.0Ag/0.5Cu

回流焊：最多 2 次

Max.2 times for re-flowing

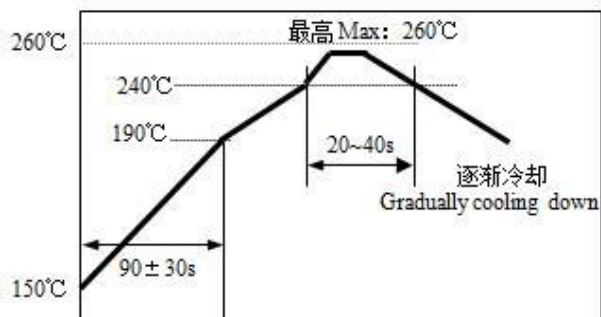

#### 手工焊 Iron Soldering Profile

烙铁功率：最大 30W

Iron soldering power: Max.30W

预热：150°C/60 sec.

Pre-heating: 150°C/60 sec.

烙铁头温度：最高 350°C

Soldering Tip temperature: 350°C Max.

焊接时间：最多 3sec.

Soldering time: 3 sec Max.

焊锡：Sn/3.0Ag/0.5Cu

Solder paste: Sn/3.0Ag/0.5Cu

手工焊：最多 1 次

Max.1 time for iron soldering

[注：不要使烙铁头接触到端头]

[Note: Take care not to apply the tip of the soldering iron to the terminal electrodes.]

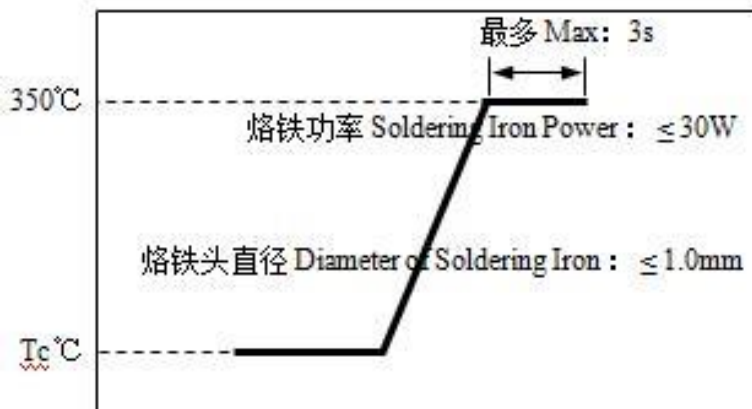

## 编带包装: Taping and packaging Specification

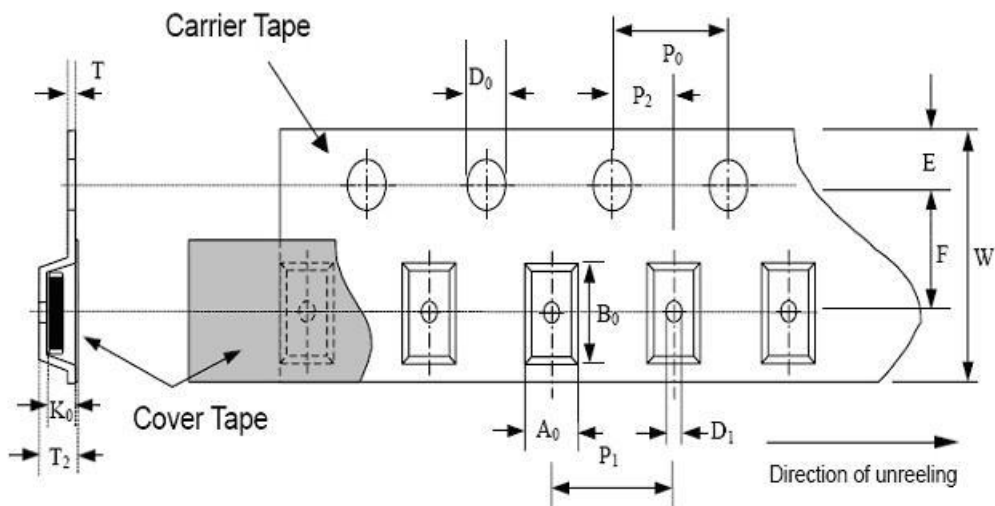

Type	A <sub>0</sub> ±0.20	B <sub>0</sub> ±0.20	K <sub>0</sub> ±0.10	T max	T <sub>2</sub> max	D <sub>0</sub> +0.05	D <sub>1</sub> ±0.05	P <sub>1</sub> ±0.10	P <sub>2</sub> ±0.05	P <sub>0</sub> ±0.1	W ±0.30	E ±0.10	F ±0.05
3220	7.0	8.7	3.85	0.3	5.50	1.55	1.55	12.00	2.00	4.00	16.00	1.75	7.50
4032	8.4	10.8	3.85	0.3	5.50	1.55	1.55	12.00	2.00	4.00	24.00	1.75	11.50

## 卷轴尺寸 Reel dimension

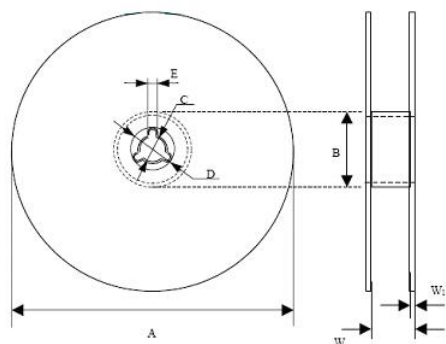

Type	A	B	C	D	E	W-W1	W <sub>1</sub>
3220-4032	329.0±1.0	60.0±0.5	13.0±0.2	21.0±0.2	2.0±0.5	17.2±0.7	2.3±0.15

## 盘装数量 Quantity of taping packing (pcs): 1000

RoHS	
	LOT : P/N : QTY: KPCS N.W: KGS G.W: KGS

