

1. General Description

The HAL204 is fabricated from mixed signal CMOS technology. It internally includes an on-chip Hall voltage generator, a voltage regulator for operation with supply voltages of 1.65 to 5.5V, a sleep/awake logic for low power consumption, temperature compensation circuitry, small-signal amplifier, Hall sensor with dynamic offset cancellation system, Schmitt trigger and an open-drain output. Both south pole and north pole of sufficient strength will turn the sensor output on. The output will be turned off under no magnetic field. While the magnetic flux density (B) is larger than operating point (Bop), the output will be turned on (low), the output is held until B is lower than release point (Brp), and then turned off.

The total power consumption in normal operation is typically 15 μ W with a 3.3V power source. Operating temperature range of the HAL204 is from -40°C to 85°C.

2. Features and Benefits

CMOS Hall IC Technology

Strong RF noise protection

1.65 to 5.5V for battery-powered applications

Micropower consumption

Multi Small Size option

Low sensitivity drift in crossing of Temp. range Ultra Low power consumption at 5uA (Avg)

High ESD Protection, HBM> +/- 4KV(min) Totem-pole output

Package: TO-92S, SOT23-3, SOT553, DFN1216-4L

3.Applications

Solid state switch

Handheld Wireless Handset Awake Switch (Flip Cell/PHS Phone/Note Book/Flip Video Set)

Magnet proximity sensor for reed switch replacement in low duty cycle applications

Notebook / PAD PC / PDA

4. Typical Application Circuit

Our pole-independent sensing technique allows for operation with either a north pole or south pole magnet orientation, enhancing the manufacturability of the device. The state-of-the-art technology provides the same output polarity for either pole face.

It is strongly recommended that an external bypass capacitor be connected (in close proximity to the Hall sensor) between the supply and ground of the device to reduce both external noise and noise generated by the chopper-stabilization technique. This is especially true due to the relatively high impedance of battery supplies.

5. Functional Block Diagram

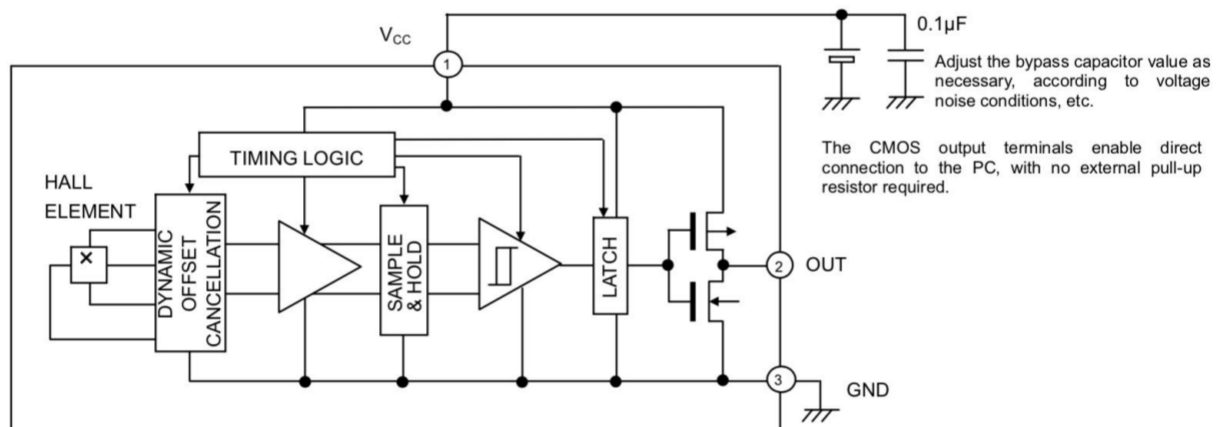

6. Pinning

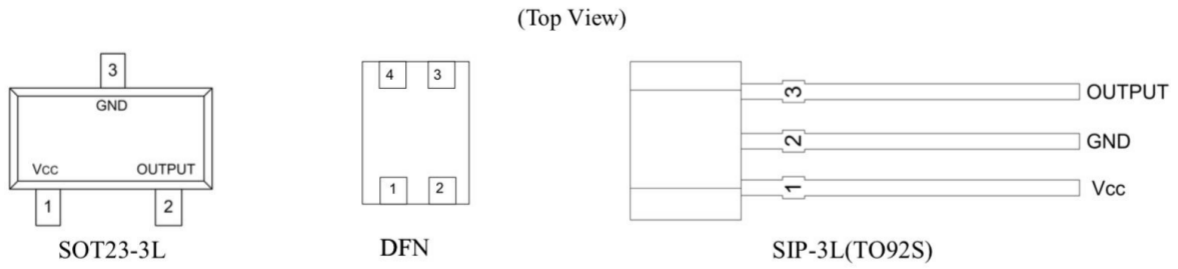

SOT Pin Number	SIP Pin Number	Pin Name	Function
1	1	VCC	Supply Voltage
2	3	OUT	CMOS Output
3	2	GND	Ground
4	NC		

SOT553

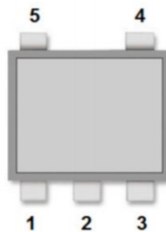

Pin Name	Pin No.	I/O	Pin Function
	SOT553		
VCC	4	P	Input Power Supply
GND	2	P	Ground
NC	1, 3	-	Not Connected
OUT	5	O	Output Pin

7. DESCRIPTION of OPERATIONS

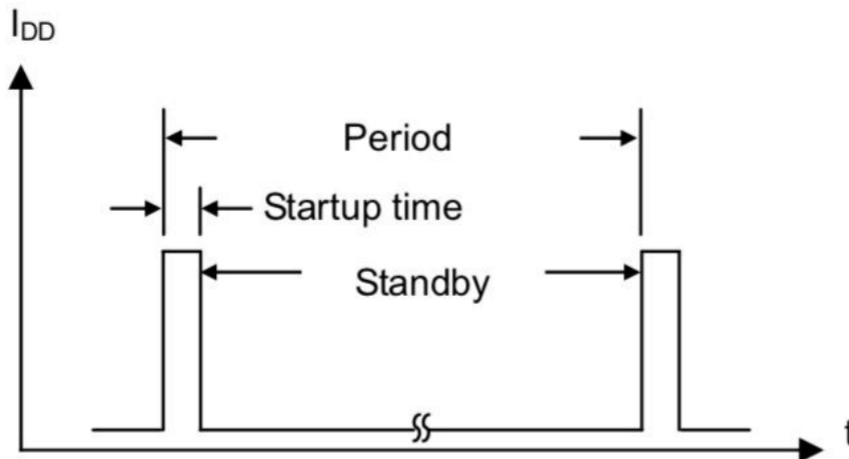

The unipolar detection Hall IC adopts an intermittent operation method to save energy. At startup, the Hall elements, amp, comparator and other detection circuit power ON and magnetic detection begins. During standby, the detection circuits power OFF, thereby reducing current consumption. The detection results are held while standby is active, and then output.

Reference period: 500us (MAX1ms) Reference startup time: 15 μ s

INTERMITTENT OPERATION at POWER ON

The unipolar detection Hall IC adopts an intermittent operation method in detecting the magnetic field during startup, as shown in Fig.5. It outputs to the appropriate terminal based on the detection result and maintains the output condition during the standby period. The time from power ON until the end of the initial startup period is an indefinite interval, but it cannot exceed the maximum period, 100ms. To accommodate the system design, the Hall IC output read should be programmed within 100ms of power ON, but after the time allowed for the period ambient temperature and supply voltage.

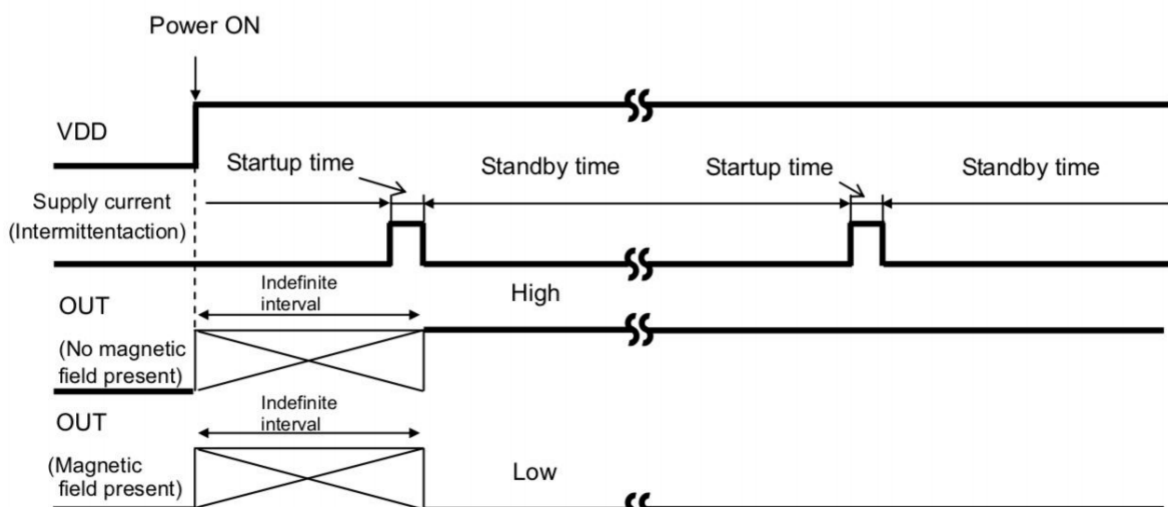

8. Typical Application Circuit

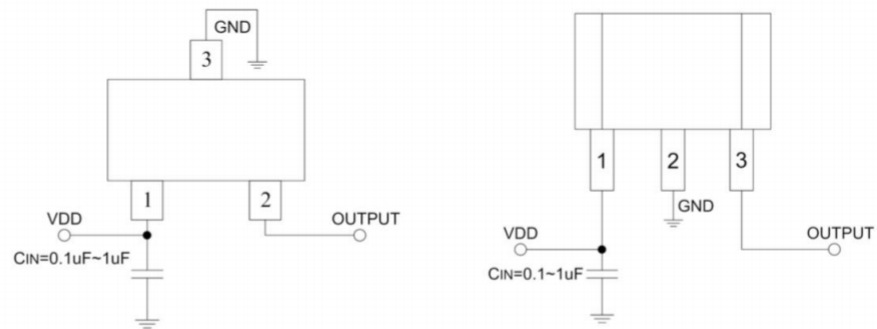

Note: C_{IN} is for power stabilization and to strengthen the noise immunity, the recommended capacitance is 0.1~1 μ F.

9. Absolute Maximum Ratings

Parameter	Symbol	Value	Units
Supply Voltage(operating)	V_{DD}	6	V
Supply Current	I_{DD}	1	mA
Output Voltage	V_{OUT}	6	V
Output Current	I_{OUT}	1	mA
Operating Temperature Range	T_A	-40 to 85	$^{\circ}$ C
Storage Temperature Rang	T_S	-50 to 150	$^{\circ}$ C
ESD Sensitivity	-	4000	V

Exceeding the absolute maximum ratings may cause permanent damage. Exposure to absolute-maximum rated conditions for extended periods may affect device reliability.

10. DC Electrical Characteristics

DC Operating Parameters: $T_A = 25^\circ\text{C}$, $V_{DD}=2.75\text{V}$.

Parameter	Symbol	Test Conditions	Min	Typ	Max	Units
Operating voltage	V_{DD}	Operating	1.65	3.3	5.5	V
Output High Voltage	V_{OH}	$B < BrpS$ $I_{OUT} = -0.5\text{mA}$	$V_{DD}-0.2$	-	-	
Output Low Voltage	V_{OL}	$BopS < B$ $I_{OUT} = +0.5\text{mA}$	-	-	0.2	
Supply current 1	$I_{DD1 (AVG)}$	$V_{DD}=1.8\text{V}$, Average	-	20	-	μA
Supply Current During Startup Time 1	$I_{DD1 (EN)}$	$V_{DD}=1.8\text{V}$, During Startup Time Value	-	0.7	-	mA
Supply Current During Standby Time 1	$I_{DD1 (DIS)}$	$V_{DD}=1.8\text{V}$, During Standby Time Value	-	1.4	-	μA
Supply current 1	$I_{DD1 (AVG)}$	$V_{DD}=3.0\text{V}$, Average	-	35	-	μA
Supply Current During Startup Time 1	$I_{DD1 (EN)}$	$V_{DD}=3.0\text{V}$, During Startup Time Value	-	0.8	-	mA
Supply Current During Standby Time 1	$I_{DD1 (DIS)}$	$V_{DD}=3.0\text{V}$, During Standby Time Value	-	2	-	μA
Awake mode time	T_{AW}	Operating	-	15	-	μS
Sleep mode time	T_{SL}	Operating	-	500	1000	μS

11. Magnetic Characteristics

Operating Parameters: $T_A = 25^\circ\text{C}$, $V_{DD} = 2.75V_{DC}$.

Symbol	Parameter	Test Conditions	Min.	Typ.	Max.	Units
B _{OPS}	Operated point	$T_A = 25^\circ\text{C}$	10	35	60	Gs
		$T_A = -40^\circ\text{C}$ to 85°C	-	37	-	
B _{OPN}		$T_A = 25^\circ\text{C}$	-60	-35	-10	
		$T_A = -40^\circ\text{C}$ to 85°C	-	-37	-	
B _{RPS}	Release point	$T_A = 25^\circ\text{C}$	10	23	60	
		$T_A = -40^\circ\text{C}$ to 85°C	-	25	-	
B _{RPN}		$T_A = 25^\circ\text{C}$	-60	-23	-10	
		$T_A = -40^\circ\text{C}$ to 85°C	-	-25	-	
B _{HYS}	Hysteresis	$T_A = 25^\circ\text{C}$	-	12	-	
		$T_A = -40^\circ\text{C}$ to 85°C	-	12	-	

12. Field Direction Definition

A positive magnetic field is defined as a south pole near the marked side of the package.

If the device is powered on with a magnetic field strength between B_{RP} and B_{OP}, then the device output is determinate High. For all packages, if the field strength is greater than B_{OP}, then the output is pulled low. If the field strength is less than B_{RP}, the output is released.

13. ESD Protection

Human Body Model (HBM) tests according to: Mil. Std. 883F method 3015.7

Parameter	Symbol	Limit Values		Unit	Notes
		Min	Max		
ESD Voltage	V _{ESD}		±4	kV	

14. Performance Characteristics

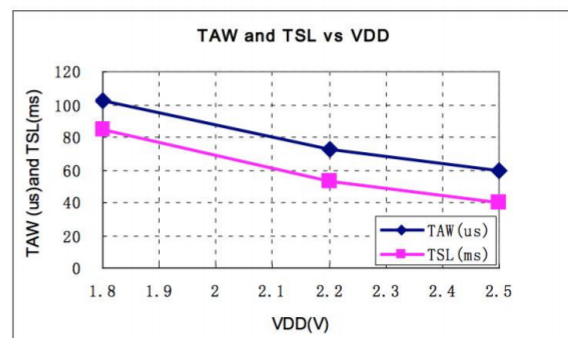
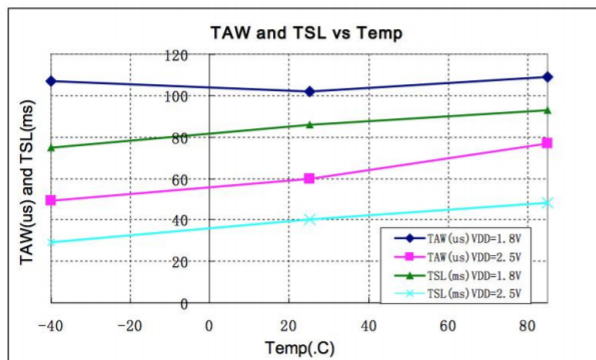
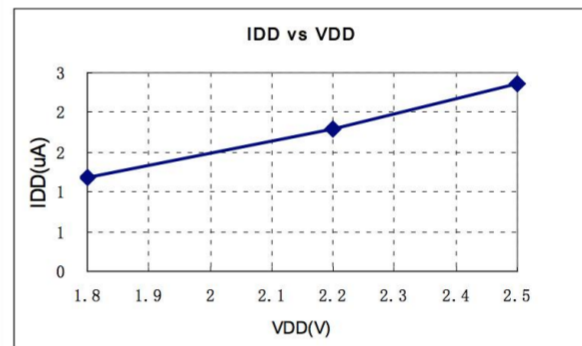
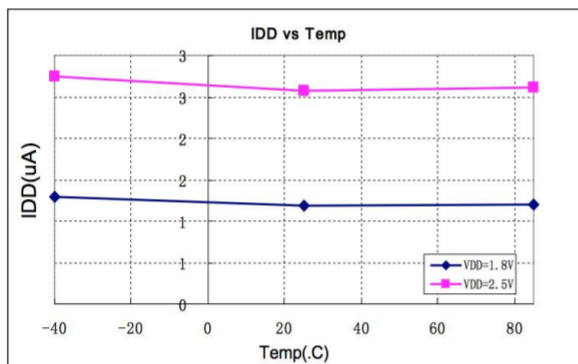
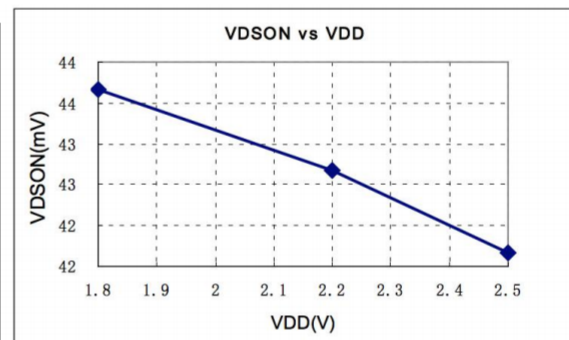
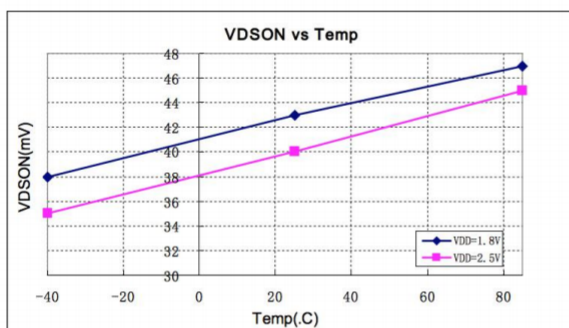
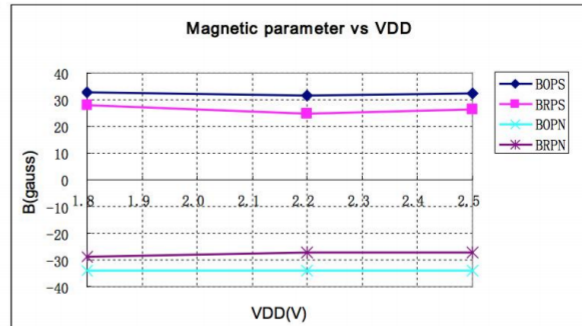
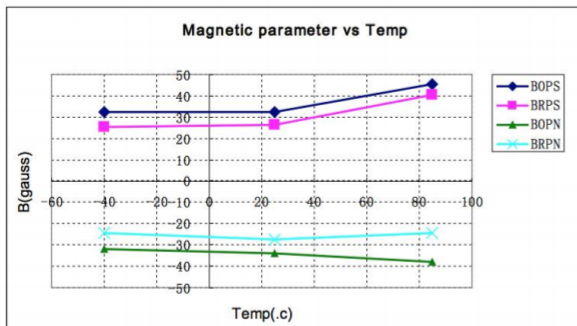

15. Unique Features

CMOS Hall IC Technology

The chopper stabilized amplifier uses switched capacitor techniques to eliminate the amplifier offset voltage, which, in bipolar devices, is a major source of temperature sensitive drift. CMOS makes this advanced technique possible. The CMOS chip is also much smaller than a bipolar chip, allowing very sophisticated circuitry to be placed in less space. The small chip size also contributes to lower physical stress and less power consumption.

Installation Comments

Consider temperature coefficients of Hall IC and magnetics , as well as air gap and life time variations.

Observe temperature limits during wave soldering. Typical IR solder-reflow profile:

- No Rapid Heating and Cooling.
- Recommended Preheating for max. 2minutes at 150 C
- Recommended Reflowing for max. 5seconds at 240 C

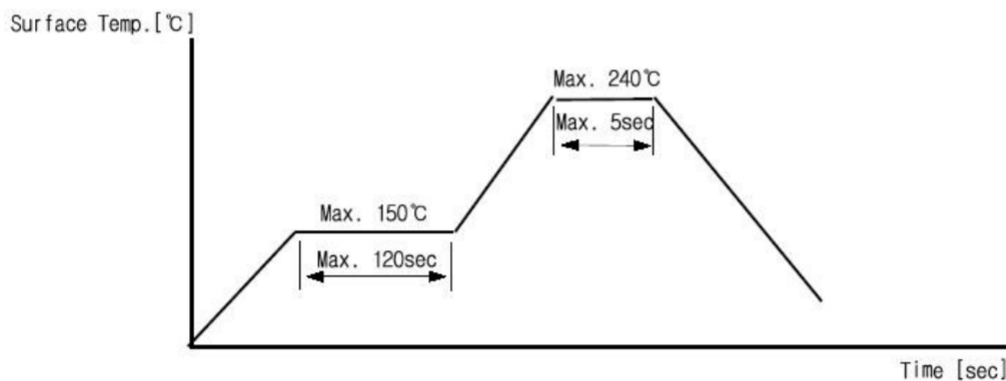

16. ESD Precautions

Electronic semiconductor products are sensitive to Electro Static Discharge (ESD). Always observe Electro Static Discharge control procedures whenever handling semiconductor products.

17. Package Information

17.1 SOT-23 Package Physical Characteristics

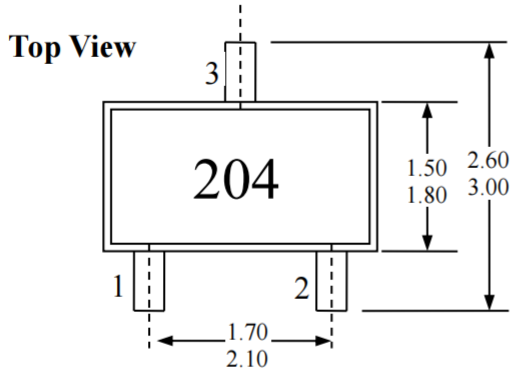

Notes:

- 1). PINOUT: **Pin 1 VDD**
 Pin 2 Output
 Pin 3 GND

2). All dimensions are in millimeters ;

Marking:

- 204** -- Code of Device (HAL204) ;
XX: production code

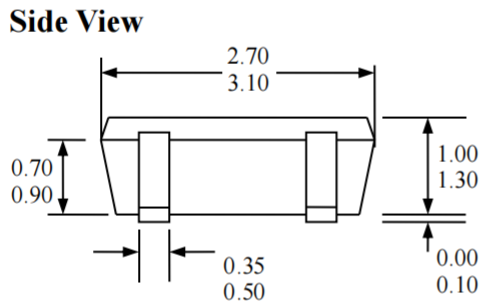

End View

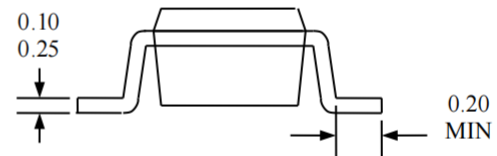

SOT-23 Package Hall Location

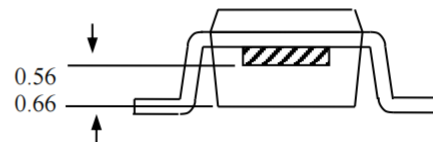
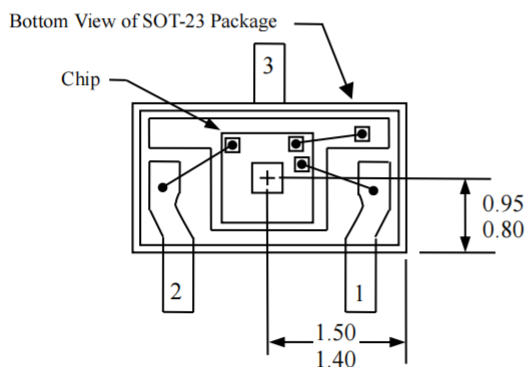

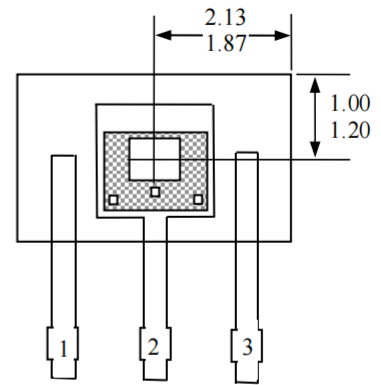
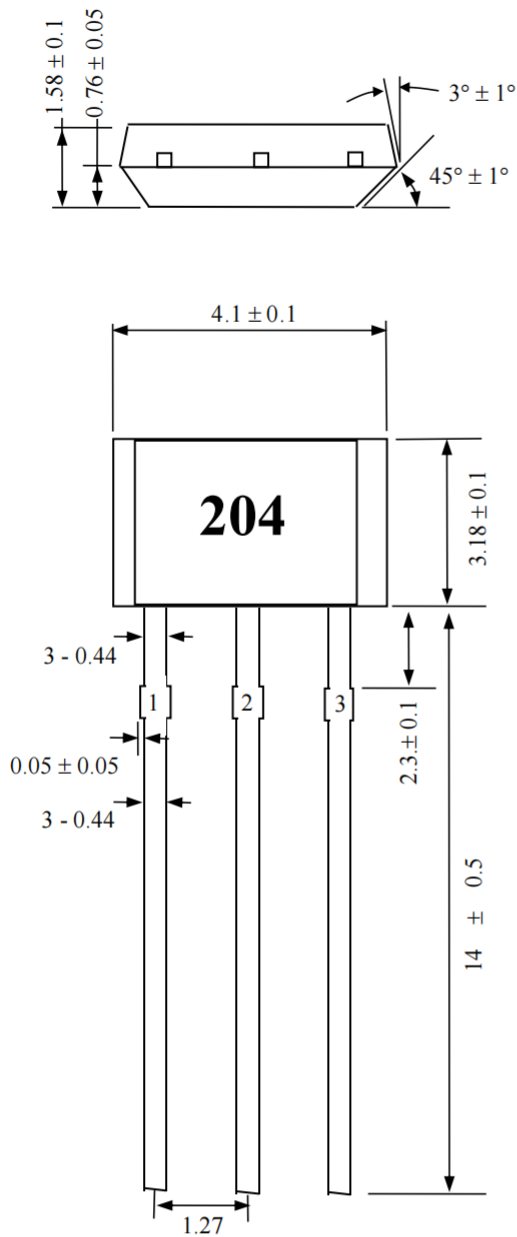
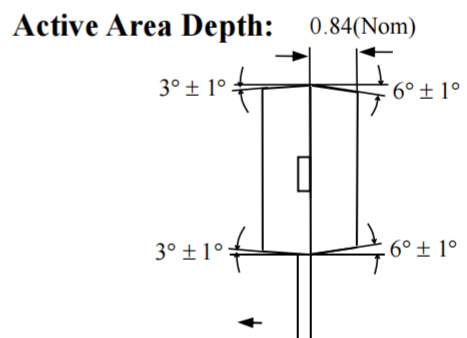
17.2 TO-92 Package Physical Characteristics

Sensor Location

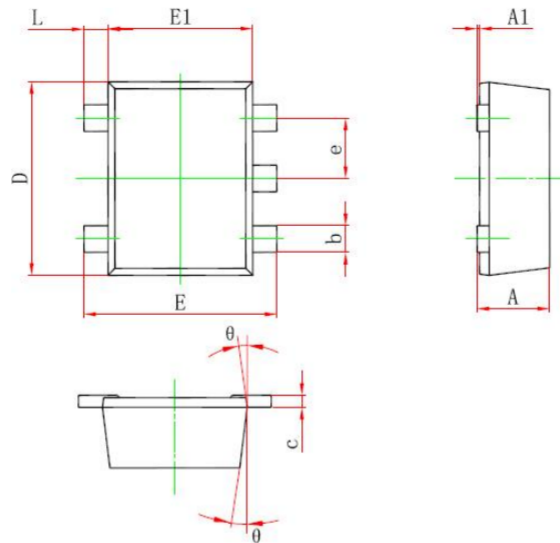
Notes:

- 1). Controlling dimension : mm ;
- 2). Leads must be free of flash and plating voids ;
- 3). Do not bend leads within 1 mm of lead to package interface ;
- 4). PINOUT: Pin 1 VDD
Pin 2 GND
Pin 3 Output

17.3 SOT553 Package Physical Characteristics

ymbol	Dimensions In Millimeters		Dimensions In Inches	
	Min.	Max.	Min.	Max.
A	0.525	0.600	0.021	0.024
A1	0.000	0.050	0.000	0.002
e	0.450	0.550	0.018	0.022
c	0.090	0.160	0.004	0.006
D	1.500	1.700	0.059	0.067
b	0.170	0.270	0.007	0.011
E1	1.100	1.300	0.043	0.051
E	1.500	1.700	0.059	0.067
θ	7°REF		7°REF	
L	0.100	0.300	0.004	0.012