

DO NOT
SCALE FROM
THIS PRINT

S1SSX-XX-XXX-XX-XX.XX-LX

FEP CABLE OPTION
-T: FEP INSULATION
LEAVE BLANK FOR PVC
(SEE NOTE 8)

No. OF POSITIONS
-02 THRU -20

WIRE GAUGE (AWG)
-28, -30

COLOR CODE
-C: COLOR CODE WIRE
(SEE TABLE 2, SHT 2)
LEAVE BLANK FOR STANDARD WIRE
(SEE TABLE 1, SHT 2)
NOT AVAILABLE FOR TEFLON OPTION,
TEFLON CABLE ONLY AVAILABLE IN
BLUE

PINOUT
(LEAVE BLANK FOR SINGLE END ASSEMBLY)
-1: LATCH DOWN, STRAIGHT
(PIN 1 TO PIN 1, SEE FIG 2, SHT 2)
-3: LATCH UP, STRAIGHT
(PIN 1 TO PIN N, SEE FIG 3, SHT 2)

LATCH OPTION
-L: PLASTIC LATCH

ASSEMBLED LENGTH
(SPECIFY IN INCHES) 01.80 IN MINIMUM

PLATING SPECIFICATION
* -T: BRIGHT ACID TIN CONTACT AND TAIL
-GF: 3µ" GOLD CONTACT AND TAIL

* = EXISTING CUSTOMERS ONLY

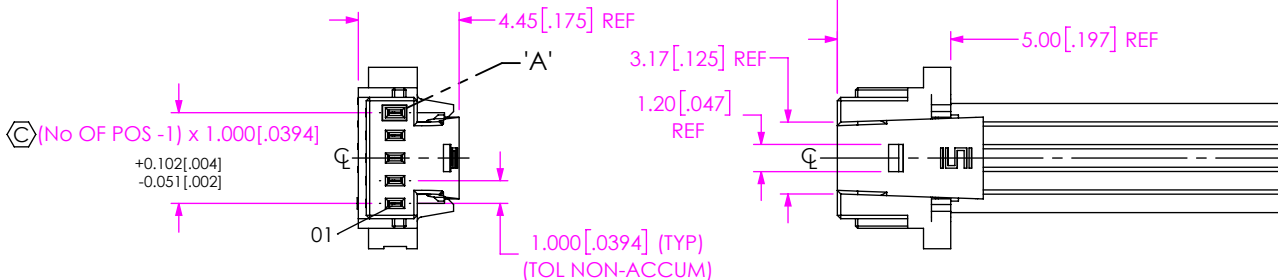
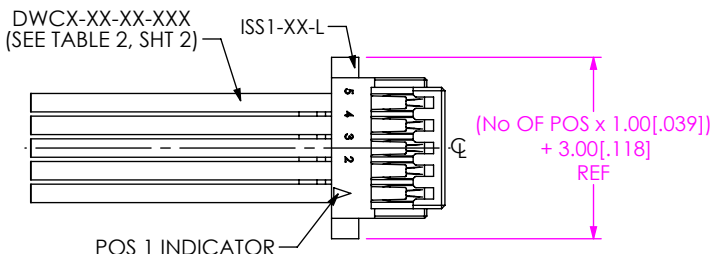
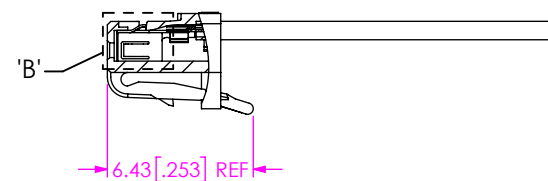
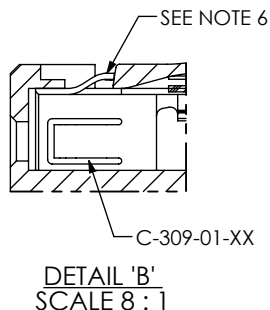
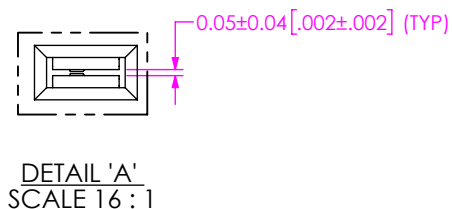

FIG 1
S1SS-05-XXX-XX-XX.XX-L SHOWN

NOTES:

1. Ⓢ REPRESENTS A CRITICAL DIMENSION.
2. MINIMUM PUSHOUT FORCE: SIGNAL: 4.445N [1.0 LB].
3. PARTS TO BE PACKAGED PER PACKAGING MANUAL.
4. FOR ASSEMBLED LENGTHS LESS THAN 13.00 IN, TOLERANCE SHALL BE ± 3.18 [.125], FOR OTHER LENGTHS, TOLERANCE SHALL BE ± 2%.
5. REFER TO CRIMP SPECIFICATIONS FOR CRIMP AND STRIP DIMENSIONS, TOLERANCES, TOOLING, AND ITS REQUIREMENTS.
6. CONTACT MUST BE INSERTED UNTIL RETENTION FEATURE LOCKS IN PLACE.
7. ASSEMBLIES TO BE ELECTRICAL TESTED INCLUDING HI-POT TEST @ 1000 VOLTS DC. AFTER FINAL ELECTRICAL TEST, MARK EACH ASSEMBLY PER INSTRUCTIONS REFERENCED IN CO-(AD-ID)-WI-3092-M.
8. ASSEMBLIES USING THE FEP OPTION ARE FOR CRIMP APPLICATIONS ONLY.

UNLESS OTHERWISE SPECIFIED,
DIMENSIONS ARE IN MILLIMETERS.

TOLERANCES ARE:

DECIMALS	ANGLES
X.X: ±0.3 [.01]	2°
X.XX: ±0.13 [.005]	
X.XXX: ±0.051 [.0020]	

PROPRIETARY NOTE

THIS DOCUMENT CONTAINS CONFIDENTIAL AND PROPRIETARY INFORMATION AND ALL DESIGN, MANUFACTURING, REPRODUCTION, USE, PATENT RIGHTS AND SALES RIGHTS ARE EXPRESSLY RESERVED BY SAMTEC, INC. THIS DOCUMENT SHALL NOT BE DISCLOSED, IN WHOLE OR PART, TO ANY UNAUTHORIZED PERSON OR ENTITY NOR REPRODUCED, TRANSFERRED OR INCORPORATED IN ANY OTHER PROJECT IN ANY MANNER WITHOUT THE EXPRESS WRITTEN CONSENT OF SAMTEC, INC.

MATERIAL: DO NOT SCALE DRAWING SHEET SCALE: 3:1

INSULATOR: NYLON, COLOR: LIGHT GREEN

CONTACT: PHOS BRONZE



520 PARK EAST BLVD, NEW ALBANY, IN 47150
PHONE: 812-944-6733 FAX: 812-948-5047
e-Mail: info@SAMTEC.COM code 53322

DESCRIPTION:
1MM CABLE ASSEMBLY

DWG. NO.
S1SSX-XX-XXX-XX-XX.XX-LX

BY: JESSIE W 8/22/2014 SHEET 1 OF 2

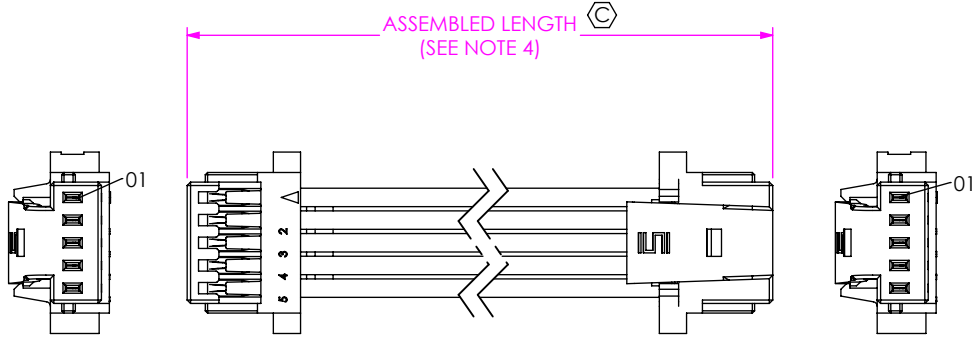
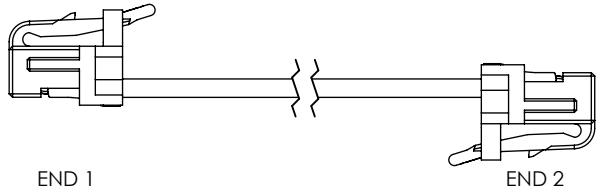

FIG 2
S1SS-05-XXX-XX-XX.XX-L1 SHOWN
(DIFFERENT AS SHOWN, OTHERWISE SAME AS FIG 1)

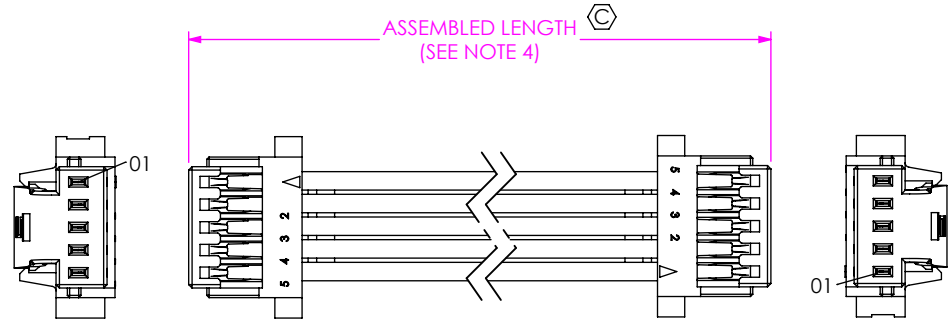
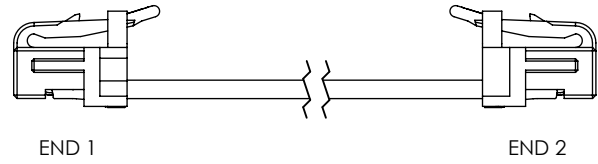

FIG 3
S1SS-05-XXX-XX-XX.XX-L3 SHOWN
(DIFFERENT AS SHOWN, OTHERWISE SAME AS FIG 1)

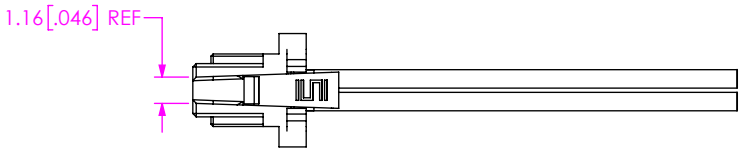

FIG 4
S1SS-02-XXX-XX-XX.XX-L SHOWN
(DIFFERENT AS SHOWN, OTHERWISE SAME AS FIG 1)
(FOR POSITIONS -02 THRU -04)

WIRE GAUGE	INSULATION	WIRE PART NUMBER
-28	PVC	DWC-28-10-300
	FEP	DWCT-28-01-TC
-30	PVC	DWC-30-10-300
	FEP	DWCT-30-01-TC

PIN #	COLOR									
	BROWN	RED	ORANGE	YELLOW	GREEN	BLUE	VIOLET	GRAY	WHITE	BLACK
	DWC-XX-01-300	DWC-XX-02-300	DWC-XX-03-300	DWC-XX-04-300	DWC-XX-05-300	DWC-XX-13-300	DWC-XX-07-300	DWC-XX-08-300	DWC-XX-09-300	DWC-XX-10-300
	1	2	3	4	5	6	7	8	9	10
	11	12	13	14	15	16	17	18	19	20

	LENGTH
-S: SINGLE END	.110 [2.79]
-D: DOUBLE END	.220 [5.59]

PROPRIETARY NOTE
THIS DOCUMENT CONTAINS CONFIDENTIAL AND PROPRIETARY INFORMATION AND ALL DESIGN, MANUFACTURING, REPRODUCTION, USE, PATENT RIGHTS AND SALES RIGHTS ARE EXPRESSLY RESERVED BY SAMTEC, INC. THIS DOCUMENT SHALL NOT BE DISCLOSED, IN WHOLE OR PART, TO ANY UNAUTHORIZED PERSON OR ENTITY NOR REPRODUCED, TRANSFERRED OR INCORPORATED IN ANY OTHER PROJECT IN ANY MANNER WITHOUT THE EXPRESS WRITTEN CONSENT OF SAMTEC, INC.

DO NOT SCALE DRAWING

SHEET SCALE: 3:1



520 PARK EAST BLVD, NEW ALBANY, IN 47150
PHONE: 812-944-6733 FAX: 812-948-5047
e-Mail info@SAMTEC.com code 55322

DESCRIPTION:
1MM CABLE ASSEMBLY

DWG. NO.
S1SSX-XX-XXX-XX-XX.XX-LX

BY: JESSIE W 8/22/2014 SHEET 2 OF 2