

编码器规格书

ENCODER SPECIFICATIONS

1 一般事项 General information	
1-1 适用型号 Applicable models	ED09D21MFB14.5A6C102016
1-2 使用环境温度 Usage environment temperature	- 30℃ ~ + 70℃
1-3 保存环境温度 Storage environment temperature	- 40℃ ~ + 70℃
1-4 测试条件 Test condition	温度: 5~35℃, 湿度: 45~85%HR Temperature:5~35℃, Moisture:45~85%HR
1-5 环保要求 Environmental requisition	本产品符合 RoHS 指令 This product is compliant with RoHS Directive
1-7 原产地 Country of origin	中国 China
2 构造 Construction	
2-1 外观 Appearance	各部件应完整, 无锈蚀、裂痕、电镀不良 Every part should finished, not exist rust flaw crack and bad plating
2-2 寸法 Measurements	依照图面规定 Under conditions prescribed by design drawing.
3 机械性能 Mechanical characteristics	
3-1 全回转角度 Total rotational angle	360°
3-2 回转力矩 Rotational torque	140~230gf.cm (旋转速度: 60° /1 秒) 0~+70℃ 140~230gf.cm (Rotational velocity : 60° /1 Sec.) 0~+70℃ 49.8 mN.m(500gf.cm Max): 0~-30℃ 旋转手感均匀, 定位点清晰, 一致性好 Feel even, positioning clear, good consistency
3-3 定位数 Number of detent	20 个定位 20 Detents
3-4 切换角度 Change-Over angle	18° ±3°
3-5 可焊性 Soldering	浸没面积至少达到 95%, 焊锡温度: 245±5℃, 焊锡时间: 3±0.5 秒 With being covered 95% min. of immersed area. Solder temperature:245±5℃, Solder dipping time: 3±0.5 sec
3-6 耐焊接热 Soldering heat-resistance	1、手工焊接温度最高 350℃±5℃, 5 秒; 2、自动焊接温度最高 260℃±5℃, 5 秒; 基板表面预热温度最高 100℃, 1 分钟以内; 3、以上过程均保证在 1 到 2 次; 4、不适用回流焊。 1. Soldering iron Max ,350℃±5℃ at 5 sec 2.Auto soldering 260℃±5℃ max. at 5 上 sec. Preheating temperature of board surface: 100℃ max. at within 1 minutes. 3. To guarantee the above process at 1 or 2 times. 4. No apply the reflow soldering.
3-7 轴压引强度 Pull-Push Strength of Shaft	98.1N Min(10Kgf Min).
3-8 螺母锁紧强度 Nut tightening strength	1.08N.m Max (11Kgf.cm Max).
3-9 轴摇晃度 Shaft wobble	在单个轴前端 0.5mm 以内位置施加压力 250gf, 轴径向偏移量小于: 1*轴长 L 尺寸 /30mm Pressure 250gf within a single shaft end of the location of the 0.5mm, Shaft radial deviant be smaller than: 1*shaft long L size/30mm
4 电气性能 Electrical characteristics	
4-1 额定电压 Voltage rating	DC 5V

4-2 额定电流 Current rating	1mA
4-3 耐电压 Voltage proof	AC 300V 1 分钟以上（端子和本体之间，端子和轴芯之间） 1 Minute at AC 300V (Between terminal – case, Between terminal –shaft).
4-4 最大使用电流 Maximum operating current	2.5mA
4-5 接触抵抗 Ratings power	10 Ω Max
4-6 绝缘抵抗 Insulation resistance	DC 250V 100M Ω 以上（端子和本体之间，端子和轴芯之间） 100M Ω min. At DC 250V (Between terminal – case, Between terminal –shaft).
4-7 分解能力 Resolution	10 个脉冲/旋转 1 周（360°） 10 pulses /Rotate a ring (360°)
4-8 输出信号 Output signal	<p>A、B 信号，相位差的输出如下： * 备注：A 信号（A-COM 间），B 信号（B-COM 间） Output of phase difference, signals A and B, is as follows. *Remark: A signal (Between A-common), B signal (Between B-common)</p>
4-9 相位差 Phase difference	<p>在没有定位的情况下 $T_d = T/4 \pm T/6$ * 备注：T=周期 In no detent circumstances $T_d = T/4 \pm T/6$ in case of no detent. *Remark: T= Cycle</p>
4-10 负荷比 Load Ratio	<p>在定位情况下: 50% ± 15% (18° ± 5.4°) In detent circumstances : 50% ± 15% (18° ± 5.4°)</p>
4-11 回转寿命 Rotational life	<p>无负荷情况下，每小时 600 周，连续旋转至 50,000 ± 200 周后： 1、接触抵抗 100 Ω 以下； 2、绝缘抵抗 10M Ω 以上 DC250V（端子和本体之间，端子和轴芯之间）； 3、耐电压 AC100V 1 分钟（端子和本体之间，端子和轴芯之间），绝缘阻抗无击穿； 4、回转力矩：≥80gf.cm； 5、外观和结构无损坏。 In no load circumstances, continuous rotation 50,000 ± 200 cycles after on 600 r/h: 1. Contact resistance:100 Ω max. 2. Insulation resistance:10M Ω min. At DC 250V. (Between terminal – case, Between terminal –shaft). 3. Withstanding voltage : AC 100V at 1 minute (Between terminal – case, Between terminal –shaft). No subversion on insulation resistance. 4. Rotational torque : ≥80gf.cm. 5. No damage on appearance and structure.</p>

5 开关的性能 Switch characteristics				
<input checked="" type="checkbox"/> 适用 Apply		<input type="checkbox"/> 不适用 No apply		
5-1 开关型式 Switch type	按压式, 2 个接点 Push type, Total two contact point			
5-2 开关回路、 Switch configuration, Contact point	单刀单掷 S.P.S.T			
5-3 开关定格电力 Switch working angle	DC 12, 0.5A			
5-4 开关按压行程 Switch push travel	0.5±0.3mm			
5-5 开关按压力 Switch push pressure	700±300gf			
5-6 开关接触电阻 Switch contact resistance	$\leq 100m\Omega$			
5-7 开关按压寿命 Operating life for momentary push switch	无负荷情况下, 每小时 600 周, 20,000±200 周后: 1、接触抵抗 1Ω 以下; 2、耐电压 AC100V 1 分钟 (开关端子和本体之间), 绝缘阻抗无击穿; 3、开关按压力: $\geq 300gf.cm$; 4、外观和结构无损坏。 In no load circumstances, after 20,000±200 cycles on 600 r/h: 1. Contact resistance: 1Ω max. 2. Withstanding voltage: AC 100V at 1 minute (Between switch terminal – case). No subversion on insulation resistance. 3. Switch push pressure: $\geq 300gf.cm$. 4. No damage on appearance and structure.			
6 防水性能 Waterproof standard characteristics				
6-1 防水标准 Waterproof standard	<input type="checkbox"/> 不适用 No apply <input checked="" type="checkbox"/> 七级防水 1.编码器轴芯轴套置于水中 1 米深处, 其它部件密封后暴露在标准大气压中, 30 分钟后电位器内部未进水; 2.管控 8~8.28 尺寸。 1.Grade -7 Of Waterproof standard Encoder's Shaft and Bush in 1M deep of water, Other component sealed after be exposed to the standard atmosphere, After 30 minutes no water into the inner of Encoder. 2.Control 8~8.28 Dimensions			
7 端子强度				
7-1 端子强度标准 Terminal strength	在端子贴近塑胶面处施加 4.9N (0.5Kgf), 停留 5 秒, (每个端子一次), 端子无脱落、破损, 以及外壳无破损, 试验后电气性能正常。 Applying the 4.9N (0.5Kgf), in the position of intersecting plastic surface and the terminals stay in 5 seconds, damage, terminals, and a shell without damage, electrical performance test after normal.			
备注 Remarks	声音参照客户样品。 Sound reference to customer samples.			
东莞市长泰尔电子有限公司 DONG GUAN CHANG TAI ER ELECTRONIC CO., LTD.		制作 Designed By	审核 Checked By	核准 Approved By
				

16 15 14 13 12 11 10 9 8 7 6 5 4 3 2 1

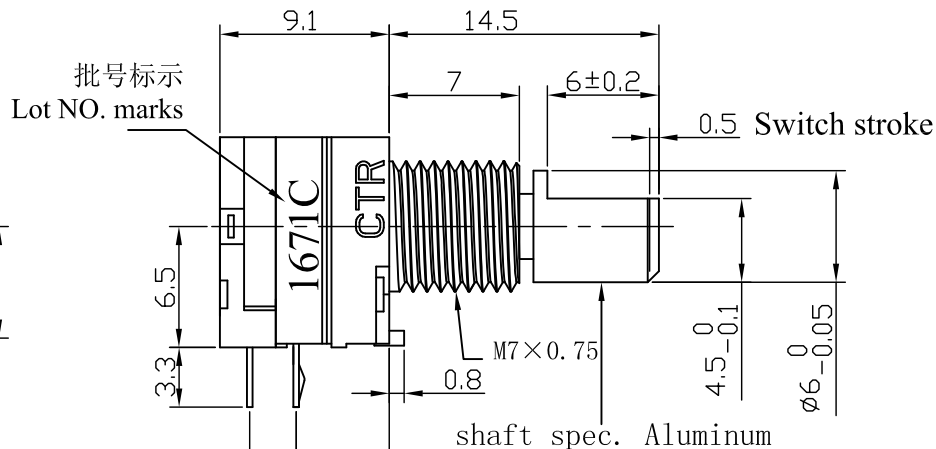
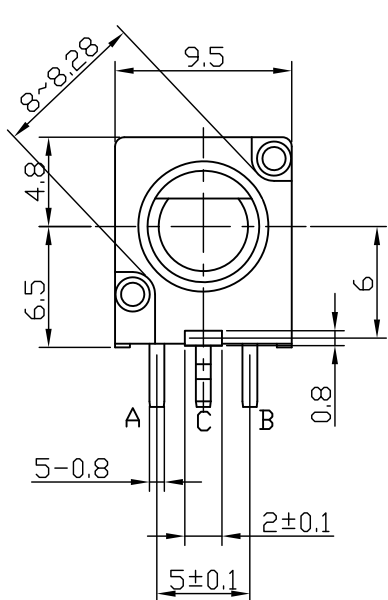
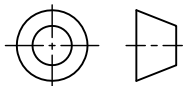

P. C. B. 安装孔详图:
P. C. B Mounting hole detail

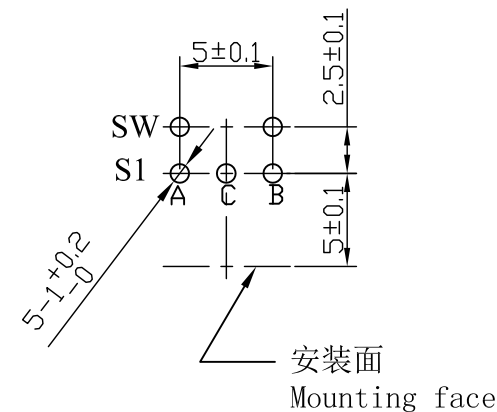

回路图:
Circuit diagram

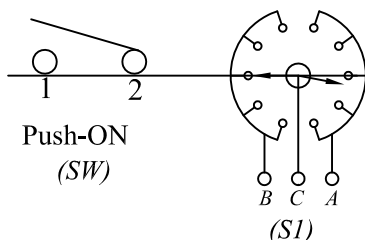

批号说明:
Lot NO. explanation

▽ 螺母锁紧强度: 1.08N.m Max
Nut tightening strength: 1.08N.m Max

配件(可选):
Fittings(Have choice)

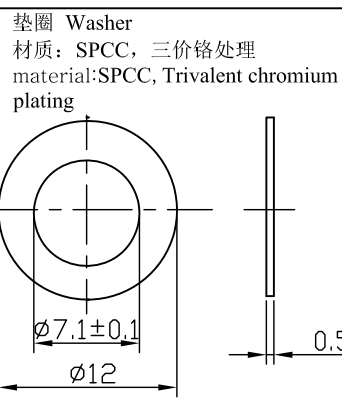
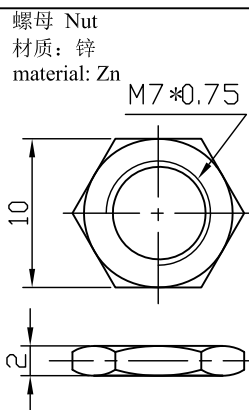

16 7 1 C
COUNTRY OF ORIGIN: C (CHINA)
WEEK CODE: 1 (1st Week) 、 2 (2nd Week) 、 ... 、 5 (5th Week)
MONTH CODE: 1 (Jan.) 、 2 (Feb.) ... O(Oct.) 、 N (Nov.) 、 D (Dec.)
YEAR CODE: 10 (2010) 、 11 (2011) 、 12 (2012) ... 19 (2019) 、 20 (2020)

▽	批号说明
▽	螺母锁紧强度由0.981N.m Min变更为1.08N.m Max
标记	变更内容
	未注尺寸公差 Gen.tolerance
	L≤1.0: ±0.1
	1.0<L≤10: ±0.3
	10<L≤30: ±0.5
	30<L≤100: ±1.0
	比例 Scale
	2.5:1
	版本 Edition
	1.2
	单位 Unit
	mm
	品名 Type Name
	编码器 ENCODER
	图号 Dwg. NO.
	ED09D21MFB14.5A6C102016

东莞市长泰尔电子有限公司
DONG GUAN CHANG TAI ER ELECTRONIC CO., LTD.

设计 Designed By	审核 Checked By	批准 Approved By
工程部 2016.07.23 谢敏	工程部 2016.07.23 喻钊	工程部 2016.07.23 彭先炎

16 15 14 13 12 11 10 9 8 7 6 5 4 3 2 1

16 15 14 13 12 11 10 9 8 7 6 5 4 3 2 1

外箱:
Outer carton Box:

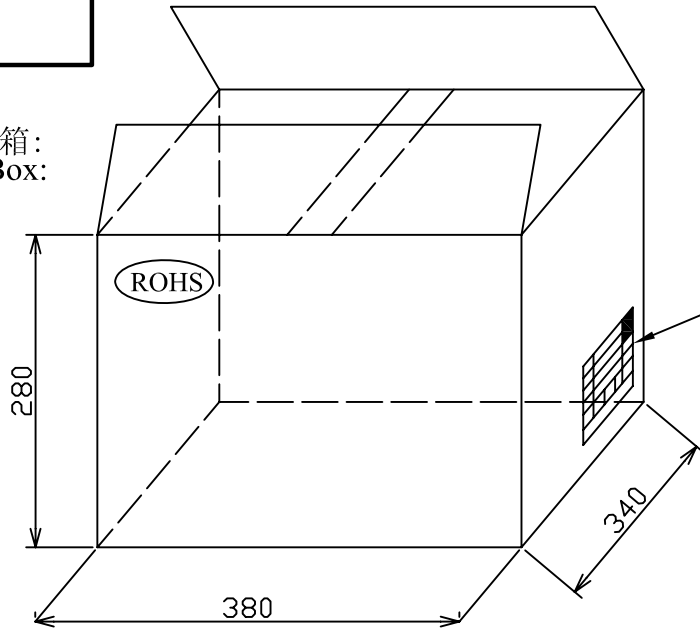

包装标签:
Packing Label:

装箱单 Packing list			
Customer 客户名称			RoHS 符合
Customer P/N 客户料号			
Type 型号规格			PO NO. 箱号
Q.T.Y 数量			Date 日期
Carton NO. 箱号	Total Carton Q.T.Y 总箱数	QC 检验	
DONG GUAN CHANG TAI ER ELECTRONIC CO.,LTD 东莞市长泰尔电子有限公司			

包装标签:
Packing Label:

Supplier 供应商			ROHS
Customer P/N 客户料号			
Type 型号			
Q.T.Y 数量	Date 日期		
Lot NO. 批号			

内箱:
Inner carton Box:

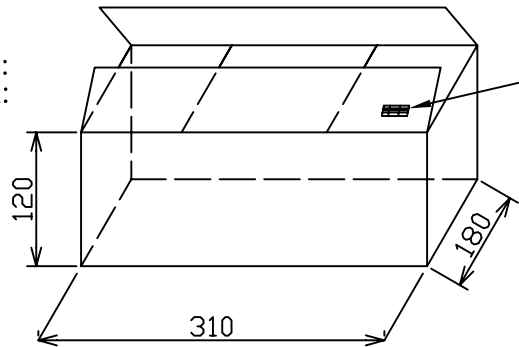

包装盒:
Parking Tray:

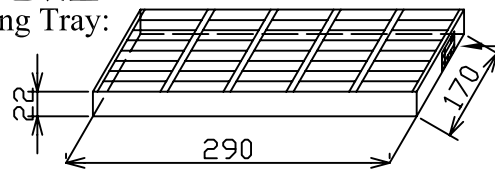

包装标签:
Packing Label:

Part NO. 料号			RoHS
TYPE 型号			
LOT NO. 批号	QTY 数量		

包装物名称 Packing name	容量 Measure
外箱 Outer carton Box	1个外箱装4个内箱 An outside carton Box put 4PCS inner carton Box
内箱 Inner carton Box	1个内箱装9块包装盒 An inner carton Box put 9PCS Tray
包装盒 Parking Tray	1块包装盒装80只产品 A tray put 80PCS Product

东莞市长泰尔电子有限公司 DONG GUAN CHANG TAI ER ELECTRONIC CO., LTD.						
单位 Unit	毫米 mm	版本 Edition	1.0	设计 Designed By	审核 Checked By	批准 Approved By
品名 Type Name	编码器 ENCODER			工程部 2014.07.16 李昌平	工程部 2014.07.16 廖金华	工程部 2014.07.16 辛文涛
图号 Dwg.NO.	ED09D21MFB14.5A6C102016					

16 15 14 13 12 11 10 9 8 7 6 5 4 3 2 1