

规格书 Specification

1. 一般事项

General in formations

1-1 适用范围

Applying range

此种规格编码器应用于电子机器。

This specification applies to encoder with carbon composition, using in electronic equipment

1-2 使用温度范围

Operating temperature range

- 2 0 ~ + 7 0 °C

1-3 试验状态

Test condition

温度 5 ~ 3 5 °C、湿度 4 5 ~ 8 5 % R H 标准状态

As our standard conditions :Temperature 5~35°C, Moisture :45~85%RH

2. 外观寸法

Appearance and dimensions

2-1 外观

Appearance

产品外观无生锈，割伤，裂缝及电镀不良等。

No harmful rust, cracks, scratches and poor plating under functioning.

2-2 尺寸

Dimensions

参考附件图号 ED09D21M-FB25.5C10-C10-2015

refer to the attached drawing No. ED09D21M-FB25.5C10-C10-2015

3. 定格

Electrical ratings

3-1 定格电压

Rated voltage

DC5V

3-2 定格电流

Rated current

1 mA. 端子应承受 2mA (负荷情况下)

1 mA. (note) Common terminal shall be withstanded at 2mA(Resistance loading)

3-3 最大使用电流

Max. Operating current

2.5 mA. 端子应承受 5mA (负荷情况下)

2.5 mA. (note) Common terminal shall be withstanded at 5mA(Resistance loading)

4. 电气的特性

Electrical characteristics

项目 Items	规格 Specifications	条件 Conditions
4-1 接触抵抗 Contact resistance	200Ω 以下 (初期值) 200Ω max .(Initial) (测量方法) 在定位点位置用我们的标准仪器测量 B-COM 和 A-COM 之间保障 200 Ω。在有疑问的情况下再测量 B-COM 之间的定位。 (Measurement condition) To guarantee 200 Ω between B-COM by our standard measurement instrument at detent position between A-COM. To measure between detents(B-COM) in case of hawing interrogation	开放电压 : DC5V 以下 电流 : 200Ω : 1mA 20MΩ: 1uA Open voltage : DC5V max Current : 200Ω range : 1mA 20MΩ range: 1uA
4-2 振动 Chattering	10ms 以下 10mc max	用 15 r.p.m 回转速度来测量每个定位之间的定格电压和定格电流。 To measure at 15 r.p.m. cycle speed supplying voltage and current for each bits.

东莞市长泰尔电子有限公司
DONG GUAN CHANG TAI ER ELECTRONICS CO.,LTD

制作
Designed By

研发工程部
2023.04.14
李阳

审核
Checked By

研发工程部
2023.04.14
喻钊

核准
Approved By

研发工程部
2023.04.14
彭先炎

项目 Items	规格 Specifications	条件 Conditions
4-3 出力信号 Output signals	A、B 2 信号，相位差的输出如下 Output of phase difference, signals A and B, is as follows. A 信号 (A—COM 间) A signal Between A-common B 信号 (B—COM 间) B signal Between B-common A 信号 (A—COM 间) A signal Between A-common B 信号 (B—COM 间) B signal Between B-common	
4-4 分解能力 Resolution	10 个脉冲(360 度旋转) 10 pulses (endless)	旋转 1 周输出脉冲 Output pulse at 1 cycle
4-5 定位数 Number of detent	20 个定位 在定位点位置时, A-COM 之间是 ON 或是 OFF. 不在定位点位置时, B-COM 之间是 ON 或是 OFF. 20 detents. Between A-common is ON or OFF at detent position. Between B-Common is ON or OFF not Specified at detent position.	
4-6 位相差 Phase difference	在没有定位的情况下 $T_d = T/4 \pm T/6$ $T_d = T/4 \pm T/6$ in case of no detent. A 信号 (A—COM 间) A signal Between A-common B 信号 (B—COM 间) B signal Between B-common	参考如下 Refer to the following. 定速 Constant speed
4-7 耐电压 Dielectric strength	绝缘阻抗无击穿 No subversion on insulated resistance.	AC300V 1 分钟。 端子与本体之间 端子与轴芯之间 AC 300V at 1 minute. Between terminal—case. Between terminal—shaft
4-8 角度 Duty ratio	在定位情况下 $50 \pm 15\%$ ($18 \pm 5.4^\circ$) $50 \pm 15\%$ ($18 \pm 5.4^\circ$) In case of detent.	

东莞市长泰尔电子有限公司 DONG GUAN CHANG TAI ER ELECTRONICS CO.,LTD	制作 Designed By	审核 Checked By	核准 Approved By
	研发工程部 2023.04.14 李阳	研发工程部 2023.04.14 喻钊	研发工程部 2023.04.14 彭先炎

规格书 Specification

5. 机械的特性 Mechanical characteristics		
项 目 Items	规 格 Specifications	条 件 Conditions
5-1 回转力矩 rotational torque	7.8~29.4 mN·m (80~300gf.cm) :0~+70℃ 49.1mN·m 以下 (500gf.cm max.) :0~-20℃ 定位感的情况下 7.8~29.4 mN·m (80~300gf.cm) :0~+70℃ 49.1mN·m max (500gf.cm max.) :0~-20℃ (with detent feeling)	
5-2 切换角度 Change over angle	18±3°	
5-3 端子强度 Terminal strength	端子没有脱落,本体没破损. 端子无弯曲. 试验后,电气性能无异常. No damage to case and terminal, such as terminal's falling off. Bent terminal shall be acceptable. Without abnormality in electrical characteristics after testing.	端子顶端垂直方向施用 4.9N (0.5kgf)的静荷重 5秒. (1个端子1次) Static load of 4.9N (0.5kgf) shall be applied to the tip of terminals for 5 sec. in vertical direction (1 time/terminal)
5-4 强度 strength	轴拉 : 98.1N min.(10kgf 以上) 轴推 : 98.1N min.(10kgf 以上) 螺母旋紧度 : 0.981N·m 以上 (10kgf.cm 以上) Shaft pull : 98.1N min.(10kgf min.) Shaft push : 98.1N min.(10kgf min.) Nut tightening : 0.981N·m min (10kgf.cm min.)	静荷重 Static load
5-5 可焊性 Solderability	浸渍部分覆盖面要超过 75% With being covered 75% min .of immersed area.	焊接温度: 230±5℃ 浸渍时间 :3±0.5 sec Solder temperature : 230±5℃ Solder dipping time :3±0.5 sec
5-6 耐焊接热 Soldering heat-resistance	满足电气性能。 机械性能无异常。 Electrical characteristics shall be satisfied. No mechanical abnormality such as a excessive play.	烙铁: 350±5℃ 3秒以内 Soldering iron : Max.3 sec .at 350±5℃
5-7 轴摇晃和弯曲 Shaft wobble and bend	径向: 1.0×(轴长/30)mm 以下 :1个轴型 横向: 0.5mm 以下. * 轴顶端加压 2.5N (250gf) Radial : 0.5×(shaft/30)mm max :single shaft Thrust: 0.5mm max. * Tip of the shaft applied 2.5N (250gf)	

东莞市长泰尔电子有限公司 DONG GUAN CHANG TAI ER ELECTRONICS CO.,LTD	制作 Designed By	审核 Checked By	核准 Approved By
			

规格书 Specification

6. 耐久性

Durability characteristics

项目 Items	规格 Specifications	条件 Conditions
6-1 无负荷试验 Without loading test	接触抵抗 1KΩ 以下 绝缘抵抗 10MΩ 以上 DC250V (端子和本体之间) (端子和轴芯之间) 耐电压 AC100V 1 分钟 (端子和本体之间) (端子和轴芯之间) 绝缘阻抗无击穿 回转力矩: 满足第 5-1 项 外观和结构无损坏 Contact resistance : 1KΩ max. Insulation resistance : 10MΩ min. at DC 250V. (Between terminal – case) (Between terminal –shaft)	无负荷下 50, 000 周 运转速度: 600 回/小时 50,000 cycles without loading. 600 continuous cycles per 1 hour.
6-2 负荷试验 loading test	Withstanding voltage : AC 100V at 1 minute (Between terminal – case) (Between terminal –shaft) No subversion on insulation resistance. Rotational torque : shall not deviate from item No. 5-1. No damage on appearance and structure.	定格负荷下 50, 000 周 运转速度: 600 回/小时 50,000 cycles with loading. 600 continuous cycles per 1 hour.

7. 耐候性

Endurance characteristics

项目 Items	规格 Specifications	条件 Conditions
7-1 耐寒性 Cold resistance	接触抵抗 200Ω 以下 绝缘抵抗 10MΩ 以上 DC 250V (端子和本体之间) (端子和轴芯之间) 耐电压 AC100V 1 分钟 (端子和本体之间) (端子和轴芯之间)	-20℃ 1 小时 (无负荷放置) 常温常湿中放 1 小时后测定. -20℃ 1 hour left without loading . To be measured after atmospheric conditions for 1 hour.
7-2 耐热性 Heat resistance	绝缘阻抗无击穿 回转力矩: 满足第 5-1 项 外观和结构无损坏 Contact resistance : 200Ω max. Insulation resistance : 10MΩ min. at DC 250V. (Between terminal – case) (Between terminal –shaft)	70℃ 240 小时 (无负荷放置) 常温常湿中放 1 小时后测定. 70℃ 240 hours left without loading. To be measured after atmospheric conditions for 1 hour.
7-3 耐湿性 Damp heat	Withstanding voltage : AC 100V at 1 minute (Between terminal – case) (Between terminal –shaft) No subversion on insulation resistance. Rotational torque : shall not deviate from item No. 5-1. No damage on appearance and structure	40℃ 90~95%RH 96 小时 (无负荷放置) 常温常湿中放 1 小时后测定. 40℃ 90~95%RH 96 hours left without loading To be measured after atmospheric conditions for 1 hour.

东莞市长泰尔电子有限公司
DONG GUAN CHANG TAI ER ELECTRONICS CO.,LTD

制作
Designed By

研发工程部
2023.04.14
李阳

审核
Checked By

研发工程部
2023.04.14
喻钊

核准
Approved By

研发工程部
2023.04.14
彭先炎

规格书 Specification

8. 保存温度 - 4 0 ~ + 7 0 °C
Storage temperature

9. 高-涂层
High-coating

10. 防水
Sealability

产品安装好后，放在 1 米深的水中 30 分钟，轴套和轴芯没浸水。
After mounting a pot product, No leak on bushing and shaft at 9.8 kPa
(0.1kgf · m²) by a hydraulic pressure for 30 min.

11. 焊接条件
Recommended conditions of
dip soldering

A 、 焊接过程要求确认

Requires confirmation at your dip soldering process.

- ①使用基板 : t=1.6mm 一边铜箔
Board One sided copper foil.
- ② 助焊剂 : 比重 0.82 以上，板的一半厚度应由发泡熔性标准来
测量其发泡表面，溶液不能流到板上。

Fluxing

To use the of min. 0.82 density, half of the board
Thickness should be standard for foaming surface
measured by foaming - fluxed, and never flow over
on the board surface.

- ③ 预热 : 基板表面温度 100°C 以下 2 分以内。
Preheating Temperature of board surface 100°C max .at within 2
minutes .

- ④ 焊接 : 260°C 以下 3 秒以内。
Soldering 260°C max. at within 3 sec.

以上过程均保证在 1 到 2 次，无铅焊接。

To guarantee the above process at 1 or 2 times, , Pb- free soldering.

B、 手工焊接温度最高 350°C ± 5°C，3 秒，无铅焊接。

Soldering iron Max ,350°C ± 5°C at 3 sec, Pb- free soldering.

<p>东莞市长泰尔电子有限公司 DONG GUAN CHANG TAI ER ELECTRONICS CO.,LTD</p>	制作 Designed By	审核 Checked By	核准 Approved By
			

规格书 Specification

13. 开关规格 Switch specification	(S 2)
13-1 形式 Switch type	
13-2 种类 接点数 Switch configuration	单联单投 S. P. S. T.
13-3 定格 Switch rating	DC 12V - 0.5A
13-4 开关行程 Switch stroke	0.5 ± 0.3 mm
13-5 开关力矩 Switch torque	9.8 N以下 (1Kgf 以下) 9.8N max. (1Kgf max.)
13-6 回转寿命 Switch life	无负荷状态下 10,000 周 10,000 cycles without load
13-7 接触抵抗 (DC5V、1A 电压降下法) Switch contact resistance (Measured by DC5V, 1A voltage drop method)	50mΩ 以下 50mΩ max. 200 mΩ 以下(10,000 周) 200 mΩ max. after 10,000 cycles
备注 Remarks	

东莞市长泰尔电子有限公司 DONG GUAN CHANG TAI ER ELECTRONICS CO.,LTD	制作 Designed By	审核 Checked By	核准 Approved By
			

16 15 14 13 12 11 10 9 8 7 6 5 4 3 2 1

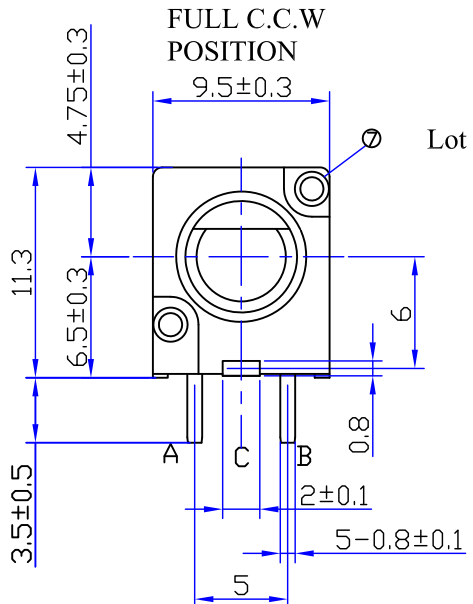
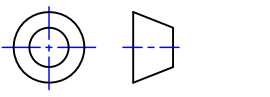

FULL C.C.W POSITION

批号标示
Lot NO. marks

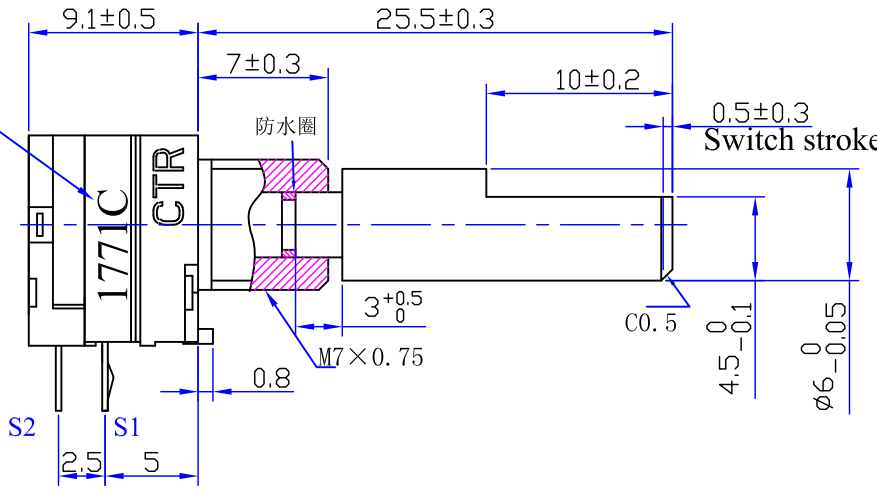

P.C.B. 安装孔详图:
P.C.B Mounting hole detail
未注公差 ±0.1
Gen. tolerance ±0.1

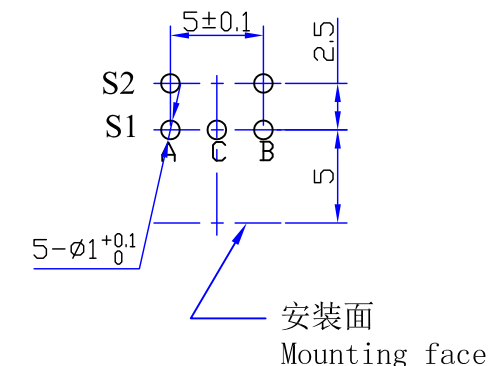

回路图:
Circuit diagram

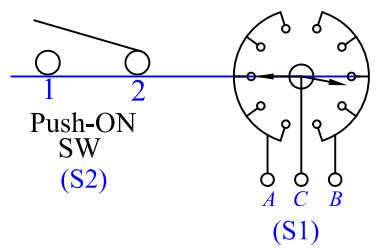

东莞市长泰尔电子有限公司 DONG GUAN CHANG TAI ER ELECTRONIC CO., LTD.								
比例 Scale	2.5:1	版本 Edition	1.0	单位 Unit	mm	设计 Designed By	审核 Checked By	批准 Approved By
品名 Type Name	ED09D21M 安装尺寸 MOUNT DIMENSION					研发工程部 2023.04.14 李阳	研发工程部 2023.04.14 喻钊	研发工程部 2023.04.14 彭先炎
图号 Dwg. NO.	ED09D21M-FB25. 5C10-C10-2015							
1.2版本 新图框	李昌平							
未注尺寸公差 Gen.tolerance	±0.2							

16 15 14 13 12 11 10 9 8 7 6 5 4 3 2 1

1、产地及生产时间 Marking detail

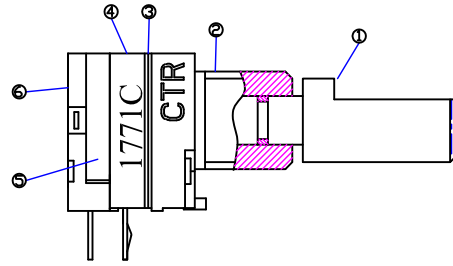

17 7 1 C

产地: C (中国)
Country of origin: C (China)

WEEK CODE: 1 (1st Week)、2 (2nd Week)、3 (3rd Week)、4 (4th Week)、5 (5th Week)

月份: 1 (1月)、2 (2月)、... O(10月)、N (11月)、D (12月)
Month code: 1 (Jan.)、2 (Feb.)、... O(Oct.)、N (Nov.)、D (Dec.)

年份: 11 (2011)、12 (2012)、13 (2013)、... 18 (2018)、19 (2019)、20 (2020)
Year Code: 11 (2011)、12 (2012)、13 (2013)、... 18 (2018)、19 (2019)、20 (2020)

2、材质 Materials

序号 NO.	部件名称 COMPONENT PART NAME	材质 MATERIAL	数量 QTY	颜色 COLOR	供应商 SUPPLIER
1	轴芯 Shaft	黄铜 Brass	1	金黄色 Gold Yellow	中国 China
2	轴套 Bushing	锌合金 Zinc alloy	1	灰色 Gery	中国 China
3	隔板 Clapboard	磷铜 Phosphor Bronze	2	棕色 Ivoy	中国 China
4	碳片塑料壳 Carbon plastic shell	Switch gasket PA66	1	蓝色 Blue	中国 China
5	开关塑壳 Switch plastic shell	POM	1	白色 White	中国 China
6	开关本体 Switch body	PBT	1	白色 White	中国 China
7	铆钉 Rivet	紫铜镀镍 Red copper plate Nickel	2	银白色 Silvery white	中国 China
	止动片 Stopping	锌合金 Zinc alloy	1	灰色 Gery	中国 China
	簧片 Reed	磷铜 Phosphor Bronze	1	棕色 Ivoy	中国 China
	电刷 Brush	锌白铜 Znic White copper	1	银白色 Silvery white	中国 China
	动臂 Boom	POM	1	黑色 Black	中国 China
	卡环 Clasp	不锈钢 Stainless steel	1	金属色 Metallic	中国 China
	开关弹片 Switch shrapnel	不锈钢镀银 Stainless steel silver	1	银白色 Silvery white	中国 China
	防水圈 Seal ability	硅胶 Silicone	1	黑色 Black	中国 China
	开关垫片 Switch gasket	PET	1	白色 White	中国 China

东莞市长泰尔电子有限公司
DONG GUAN CHANG TAI ER ELECTRONICS CO.,LTD.

版本 Edition	1.0	设计 Designed By	审核 Checked By	批准 Approved By
品名 Type Name	ED09D21M- 材质 MATERIAL	研发工程部 2023.04.14	研发工程部 2023.04.14	研发工程部 2023.04.14
图号 Dwg. NO.	ED09D21M-FB25.5C10-C10-2015	李阳	喻钊	彭先炎

外箱:
Outer carton box:
1箱放4个内箱
A box put 4 Inner carton box

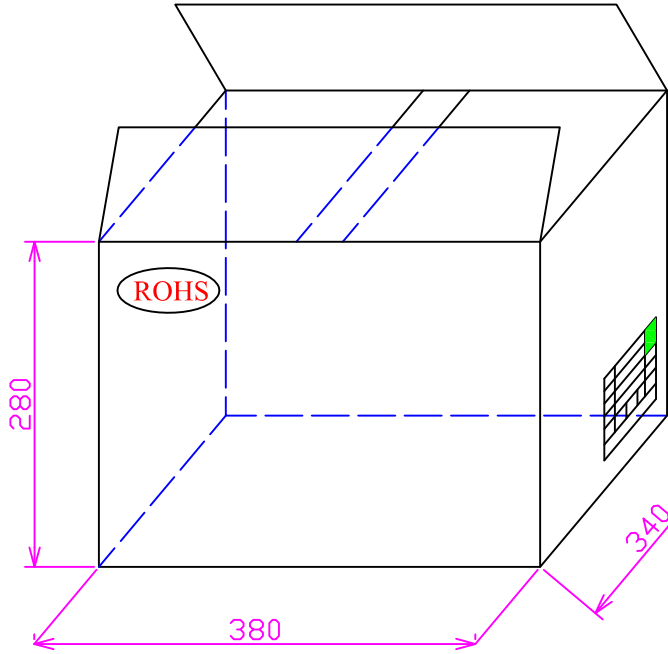

装箱标签
(packing label)

装箱单 Packing list			
Customer 客户名称			RoHS 符合
Customer NO. 客户料号			
Type 型号规格		PO No. 订单号码	
Q.T.Y 数量		Date 日期	
Box No. 箱号	Total Box QTY 总箱数	QC 检验	
DONG GUAN CHANG TAI ER ELECTRONICS CO.,LTD 东莞市长泰尔电子有限公司			

产品标签
(Item label)

Part No. 料号		RoHS
TYPE 型号		
LOT NO 批号	QTY 数量	

内箱:
Inner carton box:
1箱放9层包装盒
A box put 9 layer tray

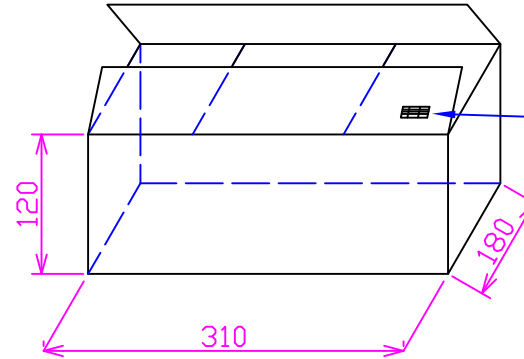

装箱标签
(Packing label)

SUPPLIER 供应商		RoHS
PART No. 料号		
TYPE 型号		
QTY 数量	DATE 日期	
LOT No. 批号		

包装盒:
Tray:
1盒放40PCS产品
A tray put 40 pcs

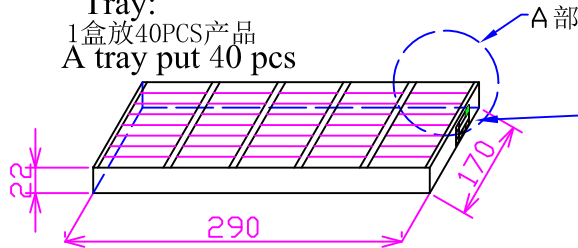

螺母、垫片包装:

Washer & nut package:

螺母、垫片分别用塑料袋装料封口;

配套装箱数量与产品数量相符合。

Washer & nut should be sealed in plastic bag respectively;

It should be packaged in every corresponding box,

Its Quantity should be equal to product quantity.

东莞市长泰尔电子有限公司
DONG GUAN CHANG TAI ER ELECTRONICS CO., LTD

单位 Unit	毫米 mm	版本 Edition	1.0	设计 Designed By	审核 Checked By	批准 Approved By
品名 Type Name	ED09D21M包装 ED09D21M Packing			研发工程部 2023.04.14	研发工程部 2023.04.14	研发工程部 2023.04.14
图号 Dwg.NO.	ED09D21M-FB25.5C10			李阳	喻钊	彭先炎