

编码器规格书

SPECIFICATIONS

适用型号 : ED08C050-SP17.4S11.5-A16-1004
APPLICABLE MODELS: ED08C050-SP17.4S11.5-A16-1004

1. 一般事项 General information

1-1 适用范围: 本规格书适用于车载机器、AV 机器、收音机、通讯设备用之 8 型金属轴编码器.

Applying range: This specification is applied to 8mm size metal shaft type encoder used in vehicle, audio-visual, radio and communication equipment.

1-2 使用温度范围 Operating temperature range $-40^{\circ}\text{C} \sim +85^{\circ}\text{C}$

1-3 储存温度范围 Storage temperature range $-40^{\circ}\text{C} \sim +85^{\circ}\text{C}$

1-4 试验的状态 温度 $5 \sim 35^{\circ}\text{C}$ 、 $45 \sim 85\% \text{RH}$ 、气压 $86 \sim 106 \text{kPa}$ 的标准状态. 当判定有疑问时, 则在以下基准状态下进行: 温度 $20 \pm 1^{\circ}\text{C}$ 、 $63 \sim 67\% \text{RH}$ 、气压 $86 \sim 106 \text{kPa}$

Test condition As our standard condition: Temperature $5 \sim 35^{\circ}\text{C}$ 、Moisture: $45 \sim 85\% \text{RH}$ 、air pressure: $86 \sim 106 \text{kPa}$. Should any doubt arise in judgment, tests shall be conducted at the following conditions:

Temperature $20 \pm 1^{\circ}\text{C}$ 、Moisture: $63 \sim 67\% \text{RH}$ 、air pressure: $86 \sim 106 \text{kPa}$.

2. 外观尺寸

Appearance and dimensions

2-1 外观 外观无锈蚀, 电镀不良, 破裂和明显变形.

Appearance No harmful rust, cracks, scratches and poor under functioning

2-2 尺寸 见附图

Dimensions Refer to attached drawing

3. 额定参数

Electrical ratings

3-1 定格电压 DC 5V

Rated voltage

3-2 定格电流 1mA(备注): 有负载的情况下, 公共端为 4mA

Rated current

1mA(Note) Common terminal shall be withstanding at 4 mA (Resistance loading)

3-3 最大使用电流 2.5mA(备注): 有负载的情况下, 公共端为 10 mA

Max. operating current

2.5mA(Note) Common terminal shall be withstanding at 10mA (Resistance loading)

4. 电气特性

Electrical characteristics

项目 Items	规格 Specifications	条件 Condition
4-1 接触抵抗 Contact resistance	接触抵抗(ON): 1Ω 以下 Contact resistance (ON) $1 \Omega \text{ max}$ 接触抵抗(OFF): $1 \text{M} \Omega$ 以上 Contact resistance (OFF) $1 \text{M} \Omega \text{ min}$	定位点位置 Detent position
4-2 耐电压 Dielectric strength	绝缘材料无击穿 No subversion on insulad resistance	AC300V 1minute 施加位置: 所有端子与接地(外壳)间 Applied position: Between all terminals and ground(frame)
4-3 绝缘电阻 Insulation resistance	$100 \text{M} \Omega$ 以上 $100 \text{M} \Omega \text{ MIN}$	DC250V 1min $\pm 5\text{S}$ 施加位置: 所有端子与接地(外壳)间 Applied position: Between all terminals and ground(frame) Applied position: Between all terminals and ground(frame)
4-4 滑动噪音 Sliding noise (BOUNCE)	3ms 以下 3ms max.	旋转速度: 600 周/H 600 continuous cycles per 1 hour

5. 机械特性 Mechanical characteristics

项目 Items	规格 Specifications	条件 Condition
----------	-------------------	--------------

型号 Model	ED08C050-SP17.4S11.5-A16-1004	版本 Edition	1.0	CT-QR2215	页码 Page	1/3
-------------	-------------------------------	---------------	-----	-----------	------------	-----

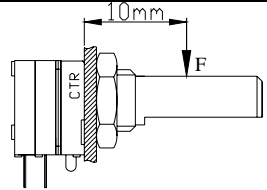
5-1 定位点力矩 Detent torque (gf.cm)	9.8 to 49.1 mN.m(100 to 500 gf.cm) : 0~+85℃ 98.1 mN.m max (1000gf.cm max): 0~-40℃ 初始值: 常温 (+25℃) 24.5 mN.m 以上 (250gf.cm 以上) Initial value: 24.5 mN.m min (250gf.cm min)	
5-2 切换角度 Switching angle	20° ±3°	
5-3 全旋转角度 Total rotational angle	300° ±5°	
5-4 端子强度 Terminal strength	端子焊接部位无松动、损坏、脱落。试验后, 端子可能弯曲,但是应满足第 4 项规定的电气参数要求。 Shall be free from terminal looseness damage and breakage of terminal holding portion.terminals may be bent after test.Electrical performance requirements specified in item 4 shall be satisfied.	在端子前端的垂直方向施加 4.9N(0.5kgf)的静载荷 15 秒钟。(每个端子 1 次) A static load of 4.9N(0.5kgf) shall be applied to the tip of terminal for 15S in a desired direction.The test shall be done once perterminal
5-5 强度 Strength	轴向拉力: 98.1N min (10kgf min) 轴向推力: 98.1N min (10kgf min) 螺母锁紧强度: 0.981N.m min (10kgf.cm min) Shaft pull: 98.1N min (10kgf min) Shaft push: 98.1N min (10kgf min) Nut tightening: 0.981N.m min (10kgf.cm min) 轴垂直押压强度:78.5N min (8kgf.cm min) Shaft vertical push: 78.5N min (8kgf.cm min)	静荷重 Static load  在 10mm 位置垂直于轴方向施加 78.5N(8kgf)并保持 10 秒。 Apply 78.5N(8kgf) static load for vertical direction of shaft for 15 seconds.
5-6 可焊性 Solderability	被浸入表面均匀的焊锡涂层, 应达到 75% 以上。 With being covered 75% min. of Immersed area.	焊锡温度: 235 ±5℃ 焊锡时间: 3 ±0.5 秒 Solder temperature: 235 ±5℃ Solder dipping time: 3 ±0.5sec
5-7 耐焊接热 Resistance to soldering heat	不应有外观及操作异常发生, 电气性能符合规格第 4 项要求。 NO abnormalities shall be observed in appearance and operation. The electrical performance requirements specified in item 4 shall be satisfied. 被浸入表面均匀的焊锡涂层, 应达到 95% 以上。 A new uniform coating of solder shall cover a minimum of 95% of the surface being immersed.	手工焊接温度最高 350℃ ±5℃, 3 秒; Soldering iron Max ,350℃ ±5℃ at 3 sec 自动焊接温度最高 260℃ ±5℃, 3 秒; Auto soldering max, 260℃ ±5℃. at 3 Sec.
5-8 轴回转止动强度 Shaft stopper strength	0.3 N.m 以上 (3kgf.cm 以上) 0.3 N.m min (3kgf.cm min)	
5-9 轴偏摆 Shaft wobble	轴柄长轴偏摆 Bush length Wobble(mm) (mm p-p 以下 less) 5 0.7×L/30 7 0.6×L/30 10 以上 MIN 0.5×L/30 L: :距轴套安装面的测量点 L: Measurement point from mounting surface of bushing.	在距安装面 30mm 轴柄的位置, 施加弯曲力矩 2.5N.m.(250gf) Bending moment of 2.5N (250gf) to be applied to the shaft at 30 mm from the mounting surface.

6.耐久性 Durability				
项目 Items	规格 Specifications	条件 Condition		
6-1 无负荷寿命 Life and no load	接触抵抗(ON): 10Ω 以下 Contact resistance (ON) 10Ω max 接触抵抗(OFF): 1MΩ 以上 Contact resistance (OFF) 1MΩ min 动作力: 7.8mN.m (80gf.cm) Min Operating force: 7.8mN.m (80gf.cm) Min 其它 4-2 项、4-3 项须满足 Shall not deviate from item No.4-2 and No.4-3	无负荷, 速度: 600 周/小时: 15,000 次 Encodet shall be operated 15, 000 cyeles at 600 cycles /H without load after which measurement shall be made.		
6-2 耐寒性 Cold resistance	符合初始规格 4-1、4-3 及 5-1 的要求。 Specification in clause 4-1、4-3 and 5-1 shall be satisfied.	-40℃ 96 小时(无负荷放置) -40℃ 96 hours left without loading.		
6-3 耐热性 Heat resistance		85℃ 240 小时(无负荷放置) 85℃ 240 hours left without loading.		
6-4 耐湿性 Damp heat	符合初始规格 4-1、4-3 及 5-1 的要求。 Specification in clause 4-1、4-3 and 5-1 shall be satisfied. 绝缘阻抗: DC250V, 3MΩ 以上 Insulation resistance: 3MΩ min at DC250V	40℃ 90-95%RH 96 小时(无负荷放置) 40℃ 90-95%RH 96 hours left without loading.		
7. 电气图表 Circuit diagram	参照所附图面 Refer to the attached drawing			
8. 表示 Marking	以下项目须在样品上或者产品包装上标示清楚。 The following items shall be marked indelibly and legibly on the specimen or each unit pack. 1. 制造厂商名称或商标: <u>CTR</u> Manufacturer's name (abbreviated manufacturer's name permitted) or trademark: <u>CTR</u> 2. 制造年月或批号: Month and year of production or code (including lot number). 3. 原产国: 中国 Country of oring: China			
9. 轴说明 Shaft specification	材质 : 不锈钢 Materials : Stainless steel			
10. 防水标准 Waterproof standard	七级防水 产品轴芯轴套置于水中 1 米深处, 其它部件密封后暴露在标准大气压中, 30 分钟后产品内部未进水。 Grade -7 Of Waterproof standard The product's Shaft and Bush in 1M deep of water, Other component sealed after be exposed to the standard atmosphere, after 30 minutes no have water into the product's inner.			
11. 注意事项 Attention item	1. 产品改良改进时须预先通知我们。 Modified for improvements without prior notice. 2. 使用场合及方法与正常方式有差异时请联络我司售后服务。 When you use the product in a different way from the usual use, please contact our sales.			
12. 本产品符合 ROHS 指令 This product is compliant with ROHS Directive				
备注 Remarks				
东莞市长泰尔电子有限公司 DONG GUAN CHANG TAI ER ELECTRONICS CO.,LTD		制作 Designed	审核 Checked	核准 Approved
		工程 2021.04.16 韦德权	工程 2021.04.16 喻判	工程 2021.04.16 彭先炎

型号 Model	ED08C050-SP17. 4S11. 5-A16-1004	版本 Edition	1.0	CT-QR2215	页码 Page	3/3
-------------	---------------------------------	---------------	-----	-----------	------------	-----

16 15 14 13 12 11 10 9 8 7 6 5 4 3 2 1

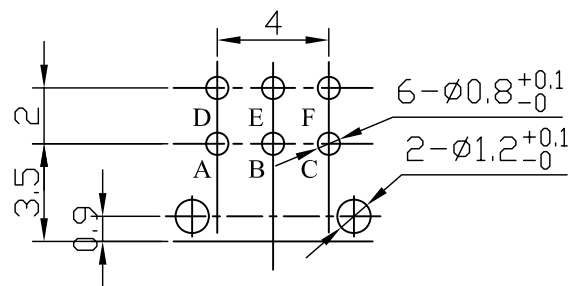
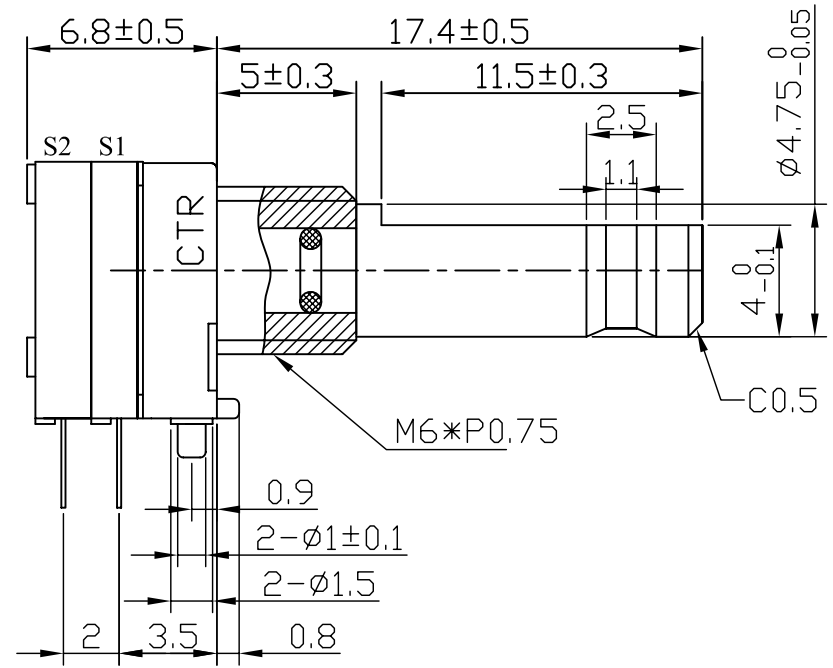
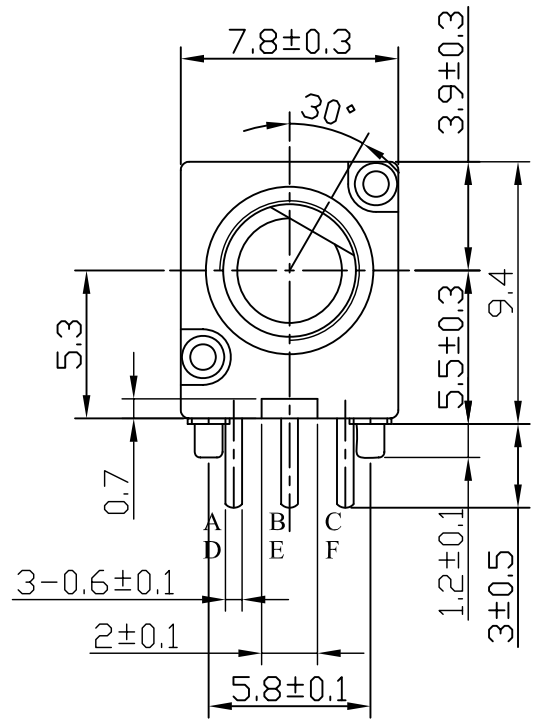
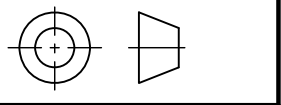

PCB Mounting Hole Detail

Detent position		A-E	E-C	D-E	E-F
FULL CCW	1	●	○	●	○
CW ↓	2	○	○	●	○
	3	○	○	○	○
	4	●	○	○	○
	5	●	●	○	○
	6	○	●	○	○
	7	○	●	●	○
	8	●	●	●	○
	9	●	●	●	●
	10	●	○	●	●
	11	○	○	●	●
	12	○	○	○	●
	13	●	○	○	●
	14	●	●	○	●
	15	○	●	○	●
	16	○	●	●	●

切换角度:20° 回转角度:300°
Switching angle Rotational angle

未注尺寸公差 Gen.tolerance ±0.2

东莞市长泰尔电子有限公司
DONG GUAN CHANG TAI ER ELECTRONICS CO.,LTD.

比例 Scale	3:1	版本 Edition	1.0	单位 Unit	mm	设计 Designed By	审核 Checked By	批准 Approved By
品名 Type Name	ED08C- 安装尺寸 MOUNT DIMENSION					工程 2021.04.16 韦德权	工程 2021.04.16 喻钊	工程 2021.04.16 彭先炎
图号 Dwg.NO.	ED08C050-SP17.4S11.5-A16-1004							

16 15 14 13 12 11 10 9 8 7 6 5 4 3 2 1

外箱:
Outer carton box:
1箱放30扎
A box put 30 Inner carton box

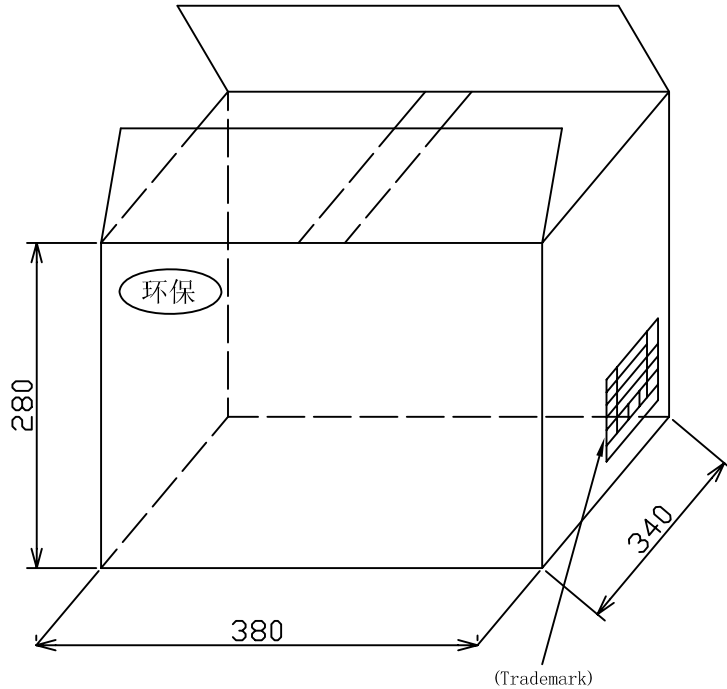

(Trademark)

装箱单			
Customer 客户名称			RoHS 符合
Model No 客户料号			
Type 型号规格			C / NO 订单号码
Q.T.Y 数量			Date 日期
Boxing No 箱号	Total Boxing QTY 总箱数		QC 检验
HONG TAI (DONG GUAN) ELECTRONICS CO.,LTD 虹泰电子(东莞)有限公司			

螺母、垫片包装:

Washer & nut package:

螺母、垫片分别用塑料袋装料封口;

配套装箱数量与产品数量相符合。

Washer & nut should be sealed in plastic bag respectively;

It should be packaged in every corresponding box,

Its Quantity should be equal to product quantity.

包装条:
Inner carton box:
1扎捆20条
A box put 20 layer box

(Trademark)

SUPPLIER 供应商			环保
ITEM CODE 料号			环保
TYPE 型号			
QTY 数量	DATE 日期		
LOTNO 批号			

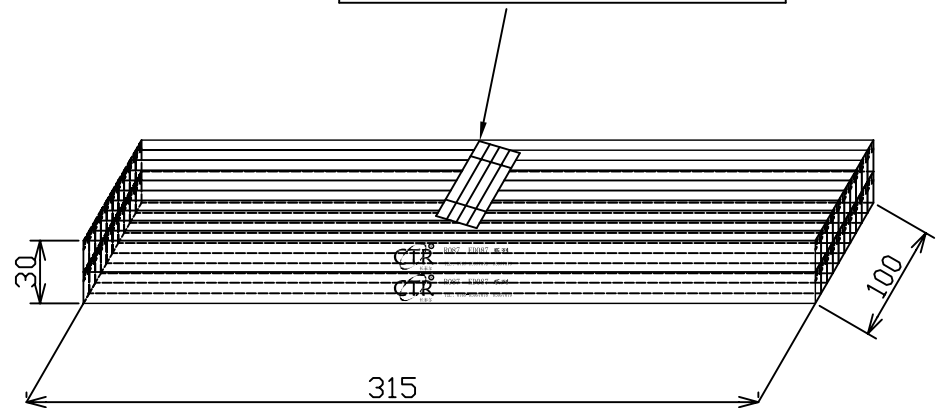

包装条:

Box:

1条放10PCS产品

A box put 10 pcs

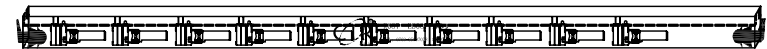

东莞市长泰尔电子有限公司
DONG GUAN CHANG TAI ER ELECTRONICS CO., LTD

单位 Unit	毫米 mm	版本 Edition	1.0	设计 Designed By	审核 Checked By	批准 Approved By
品名 Type Name	ED08C-包装 ED08C- Packing			工程部 2021.04.16	工程部 2021.04.16	工程部 2021.04.16
图号 Dwg.NO.	ED08C050-SP17.4S11.5-A16-1004			韦德权	喻钊	彭先炎