

NH6375 Series
Low Dropout Regulator



INTRODUCTION

The NH6675 series are a group of positive voltage regulators manufactured by CMOS technologies with low power consumption and low dropout voltage, which provide large output currents even when the difference of the input-output voltage is small. The NH6675 series can deliver 150mA output current and allow an input voltage as high as 50V. The series are very suitable for the battery-powered equipments, such as RF applications and other systems requiring a quiet voltage source.

INTERNAL BOX DIAGRAM

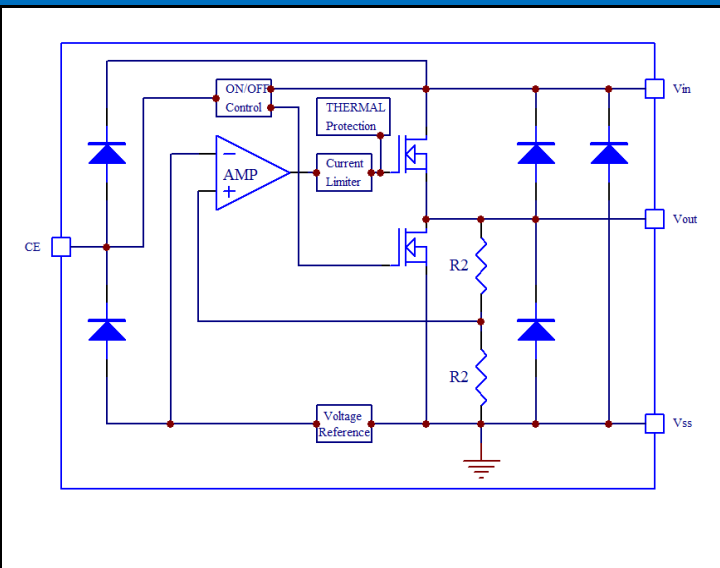

FEATURES

- Low Quiescent Current: 3uA
- Operating Voltage Range: 2.5V~50V
- Output Current: 150mA
- Low Dropout Voltage:
 - 500mV@50mA(VOUT=3.3V)
- Output Voltage: 1.2~ 12V
- High Accuracy: ±2%/±1%(Typ.)
- High Power Supply Rejection Ratio:
 - 80dB@1kHz
- Low Output Noise:
 - 27xV_{OUT} μVRMS (10Hz~100kHz)
- Excellent Line and Load Transient Response
- Built-in Current Limiter, Short-Circuit Protection
- Over-Temperature Protection
- Wireless Communication Equipments
- Portable Audio Video Equipments
- Car Navigation Systems
- LAN Cards
- Ultra Low Power Microcontroller

MODEL DEFINITION

NH6375①②③④

DESIGNATOR	SYMBOL	DESCRIPTION
①	A B	Without EN With Shutdown Function
②	Integer	Output Voltage, e.g: 3.3V=33, 5.0V=50 12V=120
③	M/ MC/ MY MF/MR	Package: SOT-23-3 Package: SOT-23-5
④	- 1	2% Accuracy 1% Accuracy

APPLICATIONS

- Cordless Phones
- Radio control systems
- Laptop, Palmtops and PDAs
- Single-lens reflex DSC
- PC peripherals with memory

MARKING

Model	Marking
NH6375①②③④	Model code+YW

NH6375 Series

Low Dropout Regulator



PIN Diagram Discription

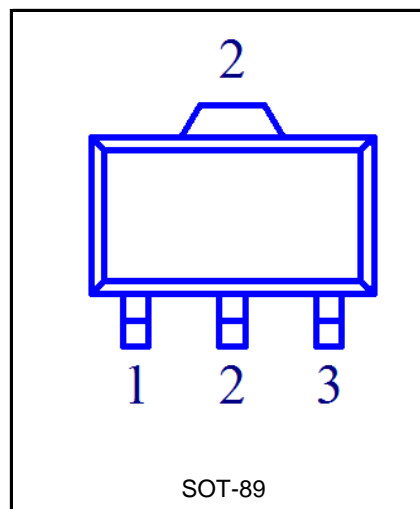
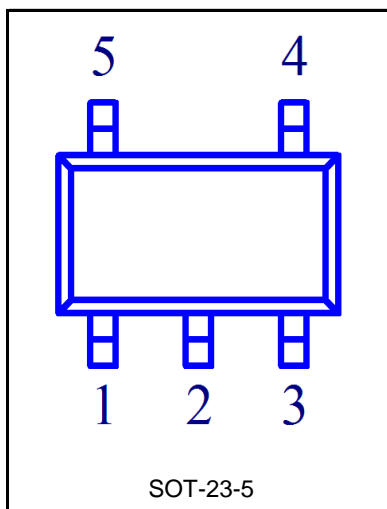
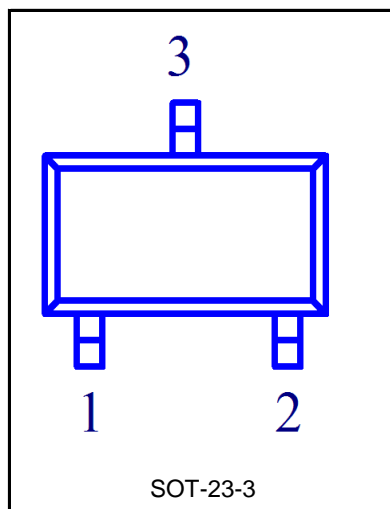

NH6375Axx Series Pin Function Discription

PIN NUMBER						PIN NAME	FUNCTION DISCIPTION
SOT-23-3			SOT-89-3				
M	MC	MY	P	PT	PL		
1	3	3	1	2	2	V_{SS}	Ground
2	2	1	3	1	3	V_{OUT}	Output
3	1	2	2	3	1	V_{IN}	Power input

NH6375Bxx Series Pin Function Discription

PIN NUMBER		PIN NAME	FUNCTION DISCIPTION
SOT-23-5			
1		V_{IN}	Power input Pin
2		V_{SS}	Ground
3		CE	Chip Enable Pin
4		NC	NO Connection
5		V_{OUT}	Output

NH6375 Series
 Low Dropout Regulator

ABSOLUTE MAXIMUM RATINGS (Note 1)

Parameter	Symbol	RATINGS	Unit	
Input Voltage (Note 2)	V_{IN}	-0.3~65	V	
Output Voltage (Note 2)	V_{out}	-0.3~15		
CE Pin Voltage (Note 2)	V_{ce}	-0.3~ $V_{in}+0.3$		
Output Current	I_{out}	400	mA	
Maximum Power Dissipation	P_D	SOT-23	0.4	W
		SOT-89	0.6	
ESD rasting (Note 3)	HBM	2	KV	
	MM	200	V	

THERMAL CHARACTERISTICS

Parameter	Symbol	Max.	Unit
Junction Temperature	T_j	-40 to +125	°C
Storage Temperature	T_{Stg}	-40 to +125	°C
Lead Temperature(Soldering, 10 sec)	T_{SOLDER}	260	°C

Note:

- Stresses beyond those listed under absolute maximum ratings may cause permanent damage to the device. These are stress ratings only, and functional operation of the device at these or any other conditions beyond those indicated under recommended operating conditions is not implied. Exposure to absolute-maximum-rated conditions for extended periods may affect device reliability.
- All voltages are with respect to network ground terminal.
- ESD testing is performed according to the respective JESD22 JEDEC standard. The human body model is a 100 pF capacitor discharged through a 1.5k resistor into each pin. The machine model is a 200pF capacitor discharged directly into each pin.

RECOMMENDED OPERATING CONDITIONS

Parameter	min.	nom.	max.	Unit
Supply voltage at V_{IN}	2.5		50	V
Operating junction temperature range, T_j	-40		125	°C
Operating free air temperature range, T_A	-40		85	°C

NH6375 Series

Low Dropout Regulator



ELECTRICAL CHARACTERISTICS(V_{IN}=V_{OUT}+1V, C_{IN}=C_{OUT}=1μF, T_A=25°C, unless otherwise specified)

PARAMETER	Condition	Symbol	Min.	Typ.(Note5)	Max.	Unit	
Input Voltage	N/A	V _{IN}	2.5	-	50	V	
Output Voltage Range	N/A	V _{OUT}	1.2	-	12	V	
DC Output Accuracy	I _{OUT} =1mA		-2	-	2	%	
			-1	-	1	%	
Dropout Voltage(note 6)	I _{OUT} =50mA, V _{OUT} =3.3V	V _{DIF}	-	500	-	mV	
Supply Current	I _{OUT} =0mA V _{IN} ≤5.0V	I _{SS}	-	3	6	μA	
	I _{OUT} =0mA V _{IN} ≥5.0V		5	10			
Line Regulation	I _{OUT} =10mA V _{OUT} +1V≤V _{IN} ≤18V	$\frac{\Delta V_{out}}{(V_{out} \times \Delta V_{IN})}$	-	0.01	0.3	%/V	
Load Regulation	V _{IN} =V _{OUT} +1V, 1mA≤I _{OUT} ≤100mA	ΔV _{out}	-	10	-	mV	
Temperature Coefficient	I _{OUT} =10mA, -40°C<T _A <125°C	$\frac{\Delta V_{out}}{(V_{out} \times \Delta T_A)}$	-	50	-	ppm/°C	
Output Current Limit	V _{OUT} =0.5×V _{OUT(Normal)} , V _{IN} =5V	I _{LIM}	150	250	-	mA	
Short Current	V _{OUT} =V _{SS}	I _{SHORT}	-	20	-	mA	
Power Supply Rejection Ratio	I _{OUT} =50mA	PSRR	100Hz	-	75	-	dB
			1KHZ	-	80	-	
			10KHZ	-	60	-	
			100KHZ	-	45	-	
Output Noise Voltage	BW=10Hz to 100kHz	V _{ON}	-	27×V _{OUT}	-	μV _{RMS}	
Thermal Shutdown Temperature	N/A	T _{SD}	-	170	-	°C	
Thermal Shutdown Hysteresis	N/A	ΔT _{SD}	-	20	-	°C	
CE"High"Voltage	N/A	V _{CE} "H"	1.5		V _{IN}	V	
CE"Low"Voltage	N/A	V _{CE} "L"			0.3	V	

NH6375 Series
Low Dropout Regulator



TYPICAL APPLICATION CIRCUIT

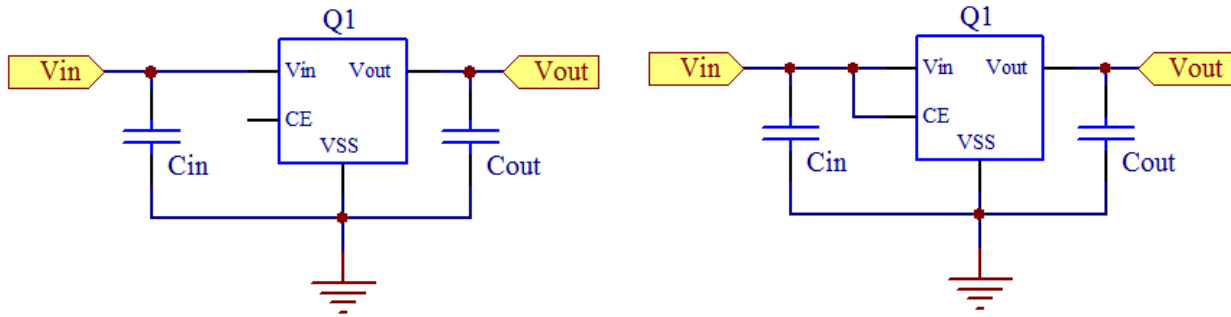

SELECTION OF INPUT/OUTPUT CAPACITORS

Phase compensation is provided to secure operation even when the load current is varied. For this purpose, use a 1.0uF or more output capacitor (C_{out}) with good frequency characteristics and proper ESR (Equivalent Series Resistance). Connect a 1.0uF or more input capacitor (C_{in}) between the V_{in} pin and the V_{ss} pin as close as possible to the pins. The value of the output overshoot or undershoot transient response varies depending on the value of the output capacitor. When selecting the output capacitor, perform sufficient evaluation, including evaluation of temperature characteristics on the actual device.

In the design of portable devices the ceramic capacitors are often chosen because of their small size, low equivalent series resistance (ESR) and high RMS current capability. Also designers have been looking to ceramic capacitors due to shortages of tantalum capacitors.

Unfortunately, using ceramic capacitors for input filtering can cause problems. Applying a voltage step to a ceramic capacitor causes a large current surge that stores energy in the inductances of the power leads. A large voltage spike is created when the stored energy is transferred from these inductances into the ceramic capacitor. These voltage spikes can easily be twice the amplitude of the input voltage step. (See "Ceramic Input Capacitors Can Cause Overvoltage Transients"—Linear Technology application note 88, March 2001)

Many types of capacitors can be used for input bypassing, however, caution must be exercised when using multilayer ceramic capacitors (MLCC). Because of the self-resonant and high Q characteristics of some types of ceramic capacitors, high voltage transients can be generated under some start-up conditions, such as connecting the LDO input to a live power source. Adding a 3Ω resistor in series with an X5R ceramic capacitor will minimize start-up voltage transients.

NH6375 Series
Low Dropout Regulator



RATING AND CHARACTERISTIC CURVES

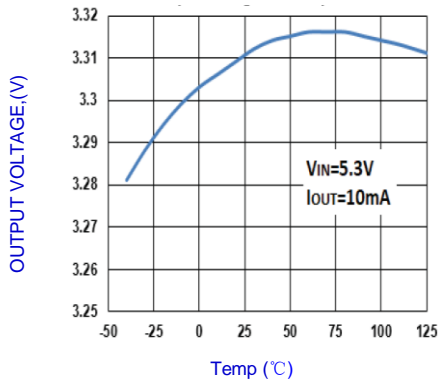

Fig.1-OUTPUT VOLTAGE VS. TEMPERATURE

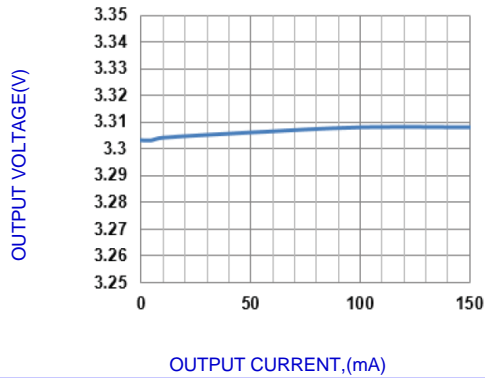

Fig.2-OUTPUT VOLTAGE VS. OUTPUT CURRENT

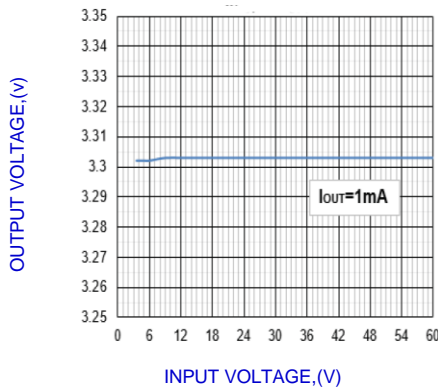

Fig.3-OUTPUT VOLTAGE VS. INPUT VOLTAGE

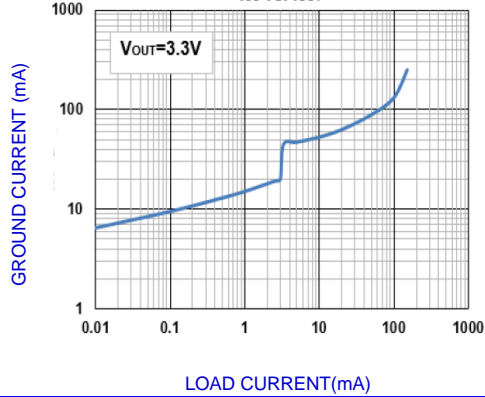

Fig.4-GROUND CURRENT VS. LOAD CURRENT

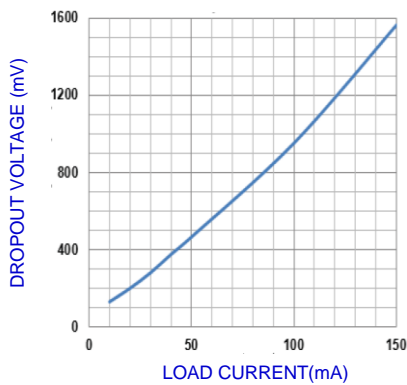

Fig.5-MAX. DROPOUT VOLTAGE VS. LOAD CURRENT

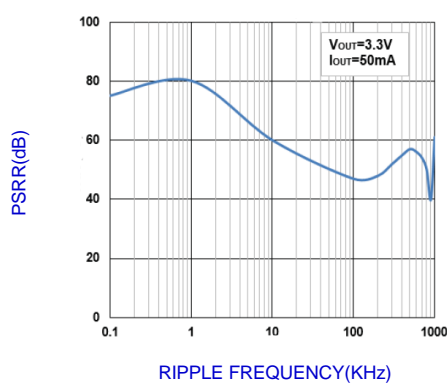

Fig.6-PSRR VS. FREQUENCY

NH6375 Series
Low Dropout Regulator



RATING AND CHARACTERISTIC CURVES

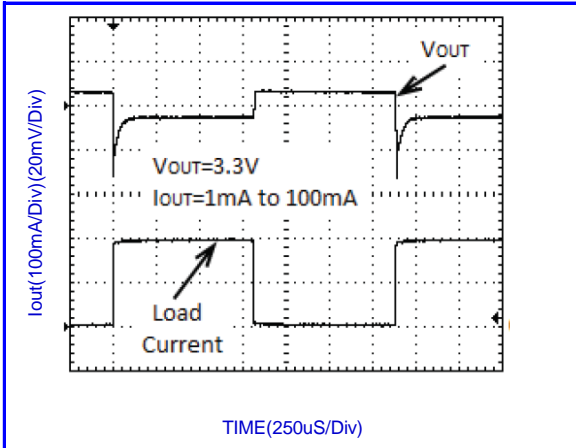

Fig.7-LOAD TRANSIENT RESPONSE

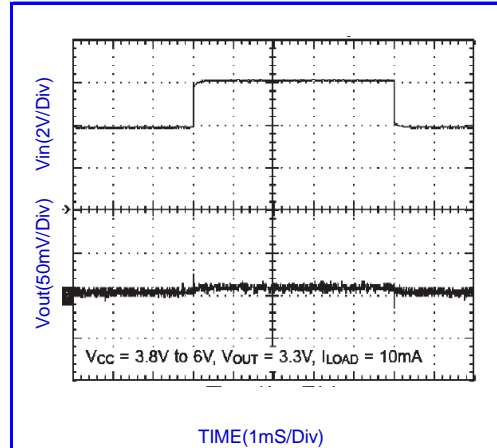

Fig.8- LINE TRANSIENT RESPONSE

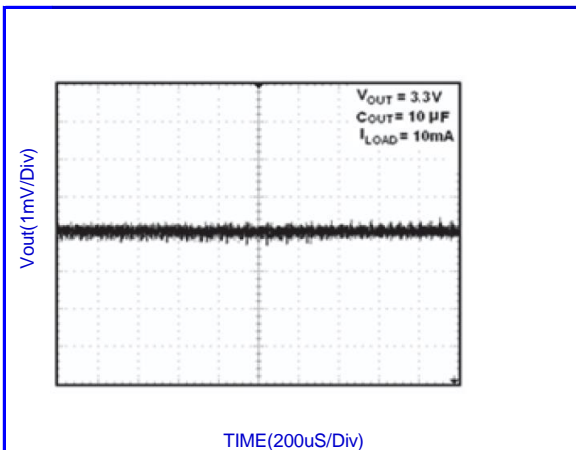

Fig.9- OUTPUT NOISE 10Hz to 100KHz

NH6375 Series
Low Dropout Regulator



OUTLINE DRAWINGS

SOT-23-3

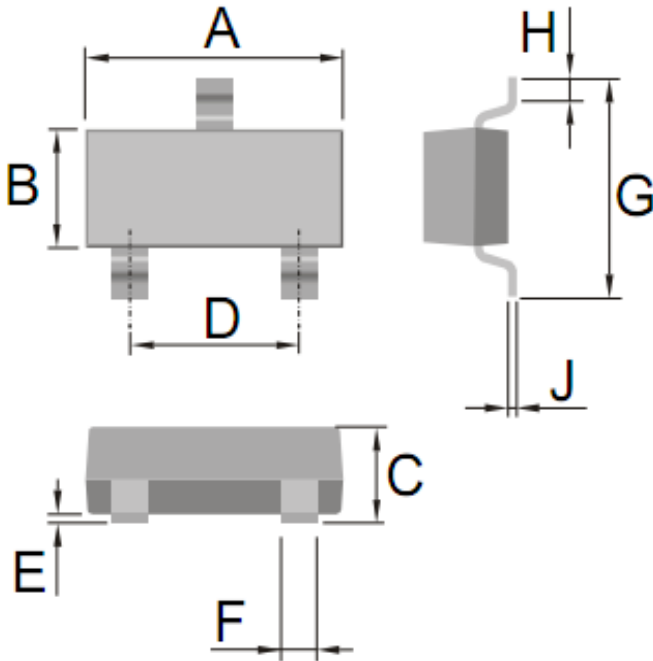

OUTLINE DIMENSIONS

Dim.	Millimeters			Inches		
	Min.	Typ.	Max.	Min.	Typ.	Max.
A	2.820	-	3.020	0.1110	-	0.1189
B	1.500	-	1.700	0.0591	-	0.0669
C	1.050	-	1.250	0.0413	-	0.0492
D	1.800	-	2.000	0.0709	-	0.0787
E	0.000	-	0.100	0.0000	-	0.0039
F	0.300	-	0.500	0.0118	-	0.0197
G	2.650	-	2.950	0.1043	-	0.1161
H	0.300	-	0.600	0.0118	-	0.0236
J	0.100	-	0.200	0.0039	-	0.0079

OUTLINE DRAWINGS

SOT-23-3

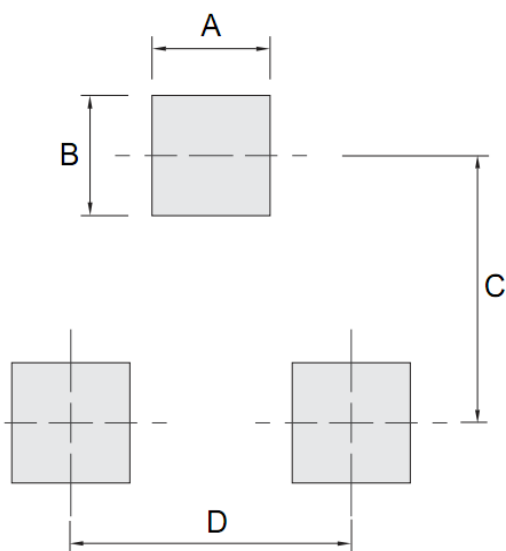

OUTLINE DIMENSIONS

Dim.	Millimeters			Inches		
	Min.	Typ.	Max.	Min.	Typ.	Max.
A	-	0.800	-	-	0.0315	-
B	-	0.900	-	-	0.0354	-
C	-	2.400	-	-	0.0945	-
D	-	1.900	-	-	0.0748	-

NH6375 Series
Low Dropout Regulator



OUTLINE DRAWINGS

SOT-23-5

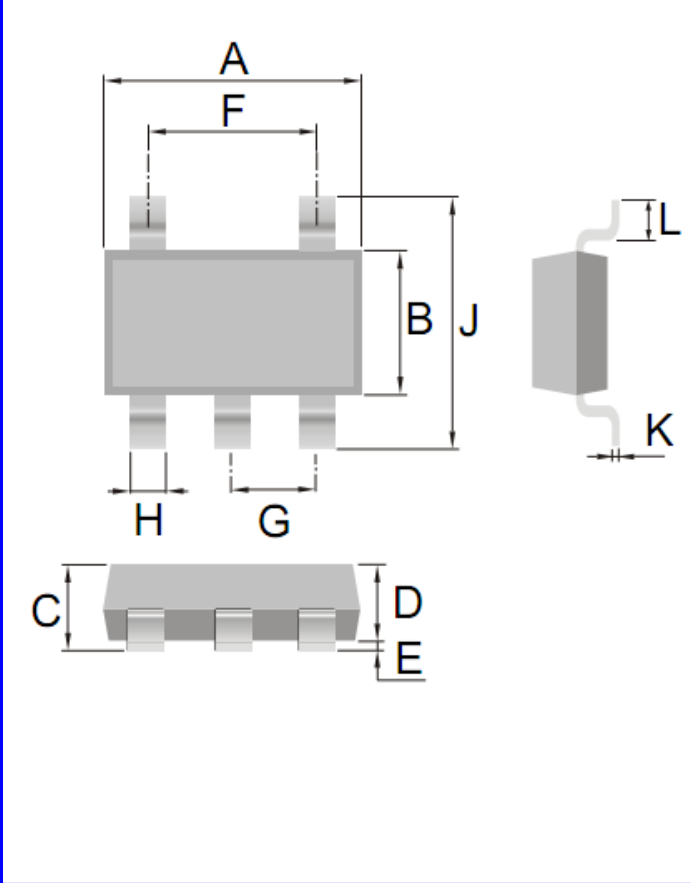

OUTLINE DIMENSIONS						
Dim.	Milimeters			Inches		
	Min.	Typ.	Max.	Min.	Typ.	Max.
A	2.820	-	3.020	0.1110	-	0.1189
B	1.500	-	1.700	0.0591	-	0.0669
C	1.050	-	1.250	0.0413	-	0.0492
D	1.050	-	1.150	0.0413	-	0.0453
E	0.000	-	0.100	0.0000	-	0.0039
F	1.800	-	2.000	0.0709	-	0.0787
G	0.900	-	1.000	0.0354	-	0.0394
H	0.300	-	0.500	0.0118	-	0.0197
J	2.650	-	2.950	0.1043	-	0.1161
K	0.100	-	0.200	0.0039	-	0.0079
L	0.300	-	0.600	0.0118	-	0.0236

OUTLINE DRAWINGS

SOT-23-5

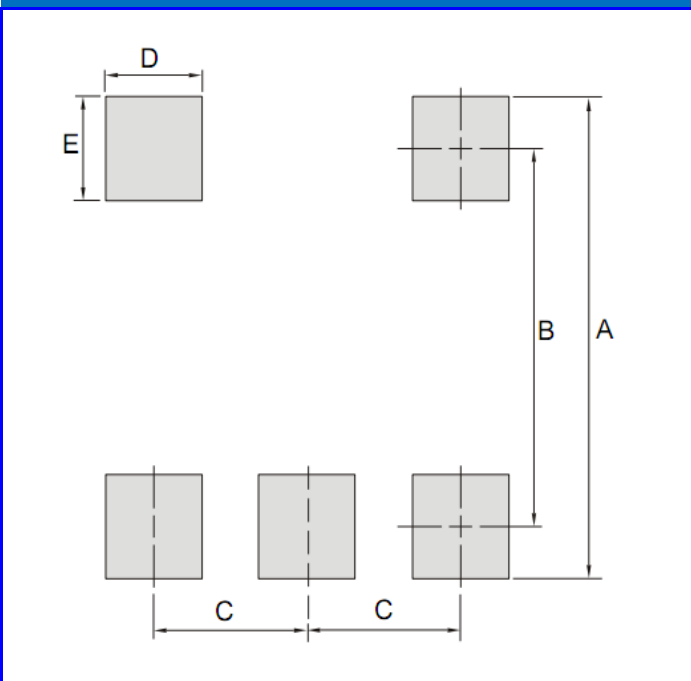

RECOMMENDED MOUNTING PAD DIMENSIONS						
Dim.	Milimeters			Inches		
	Min.	Typ.	Max.	Min.	Typ.	Max.
A	-	3.200	-	-	0.1260	-
B	-	2.250	-	-	0.0886	-
C	-	0.950	-	-	0.0374	-
D	-	0.600	-	-	0.0236	-
E	-	0.950	-	-	0.0374	-

NH6375 Series
Low Dropout Regulator



OUTLINE DRAWINGS

SOT-89

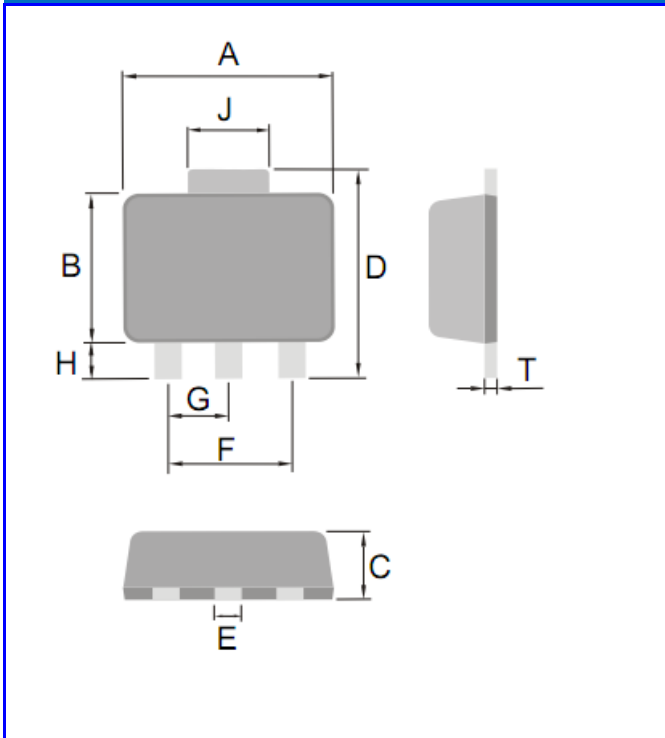

OUTLINE DIMENSIONS						
Dim.	Millimeters			Inches		
	Min.	Typ.	Max.	Min.	Typ.	Max.
A	4.400	-	4.600	0.1732	-	0.1811
B	2.300	-	2.600	0.0906	-	0.1024
C	1.400	-	1.600	0.0551	-	0.0630
D	3.940	-	4.250	0.1551	-	0.1673
E	0.320	-	0.520	0.0126	-	0.0205
F	-	3.000	-	-	0.1181	-
G	-	1.500	-	-	0.0591	-
H	0.900	-	1.200	0.0354	-	0.0472
T	0.350	-	0.440	-	#VALUE!	-

RECOMMENDED LAYOUT DRAWINGS

SOT-23

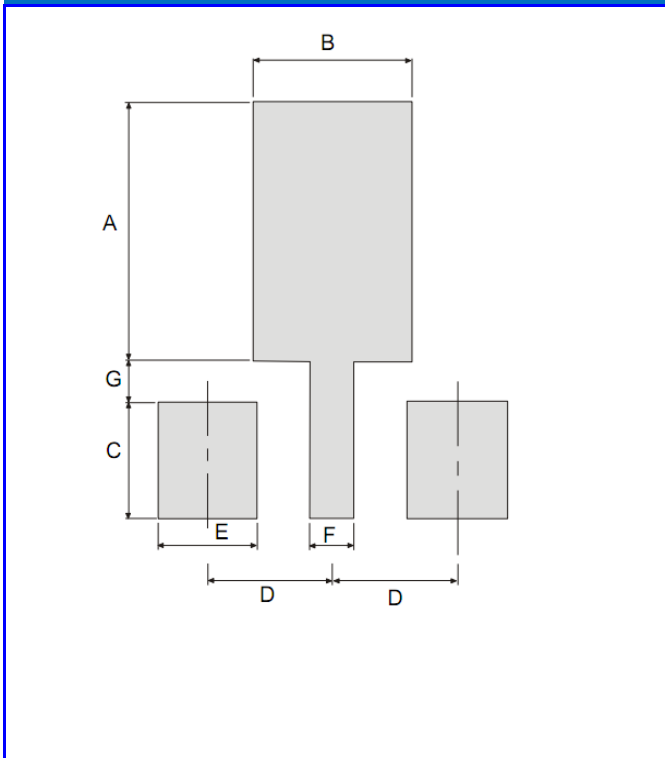

RECOMMENDED MOUNTING PAD DIMENSIONS						
Dim.	Millimeters			Inches		
	Min.	Typ.	Max.	Min.	Typ.	Max.
A	-	4.000	-	-	0.1575	-
B	-	2.400	-	-	0.0945	-
C	-	1.800	-	-	0.0709	-
D	-	1.900	-	-	0.0748	-
E	-	1.500	-	-	0.0591	-
F	-	0.700	-	-	0.0276	-
G	-	0.600	-	-	0.0236	-

NH6375 Series
Low Dropout Regulator



Recommended wave soldering condition

Product	Peak Temperature	Soldering Time
Pb-free devices	260 +0/-5 °C	5 +1/-1 seconds

Recommended temperature profile for IR reflow

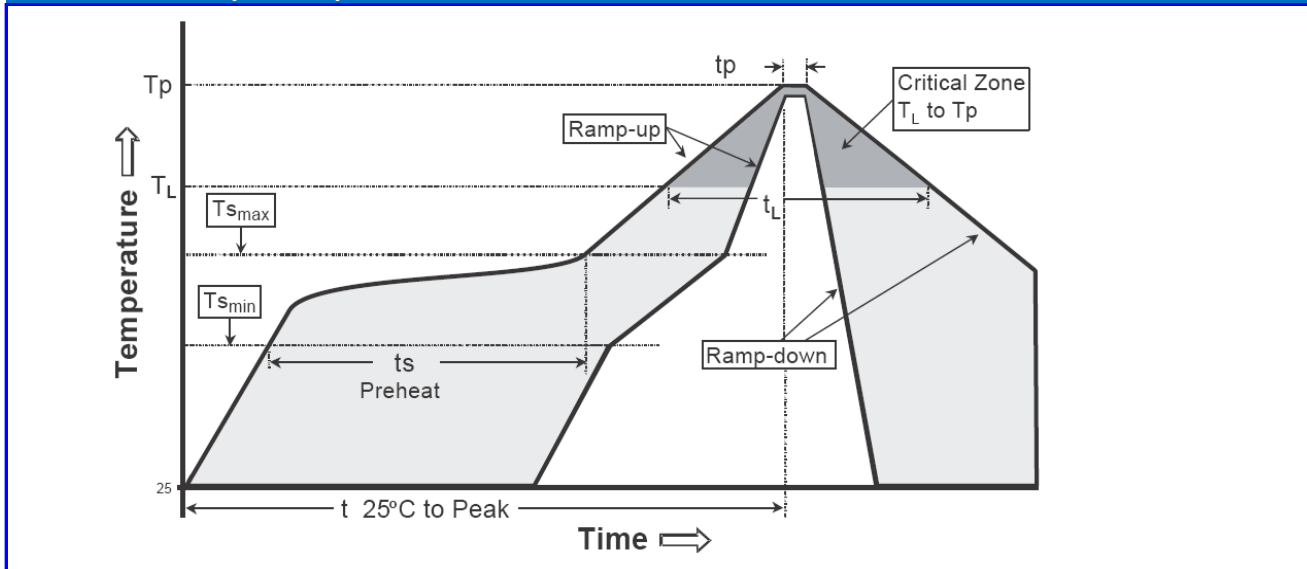

Profile feature	Sn-Pb eutectic Assembly	Pb-free Assembly
Average ramp-up rate (T _{sm} to Tp)	3°C/second max.	3°C/second max.
Preheat -Temperature Min(TS min) -Temperature Max(TS max) -Time(ts min to ts max)	100°C 150°C 60-120 seconds	150°C 200°C 60-180 seconds
Time maintained above: -Temperature (TL) - Time (tL)	183°C 60-150 seconds	217°C 60-150 seconds
Peak Temperature(TP)	240 +0/-5 °C	260 +0/-5 °C
Time within 5°C of actual peak temperature(tp)	10-30 seconds	20-40 seconds
Ramp down rate	6°C/second max.	6°C/second max.
Time 25 °C to peak temperature	6 minutes max.	8 minutes max.

Note : All temperatures refer to topside of the package, measured on the package body surface.

NH6375 Series

Low Dropout Regulator



Disclaimer

- Reproducing and modifying information of the document is prohibited without permission from niuhang Electronics co., LTD
- Niuhan Electronics co., LTD. reserves the rights to make changes of the content herein the document anytime without notification.
- Niuhan Electronics co., LTD. disclaims any and all liability arising out of the application or use of any product including damages incidentally and consequentially occurred.
- Niuhan Electronics co., LTD. does not assume any and all implied warranties, including warranties of fitness for particular purpose, non-infringement and merchantability.
- Applications shown on the herein document are examples of standard use and operation. Customers are responsible in comprehending the suitable use in particular applications. Niuhan Electronics co., LTD. makes no representation or warranty that such applications will be suitable for the specified use without further testing or modification.
- The products shown herein are not designed and authorized for equipments requiring high level of reliability or relating to human life and for any applications concerning life-saving or life-sustaining, such as medical instruments, transportation equipment, aerospace machinery et cetera. Customers using or selling these products for use in such applications do so at their own risk and agree to fully indemnify Niuhan Electronics co., LTD. for any damages resulting from such improper use or sale.
- When the appearance of the product and chip size does not change, in order to product the customer quality, change the internal structure and the production process Niuhan can not notify