



General Purpose CMOS Analog Switches

General Description

Maxim's DG381-DG390 and DG381A-DG390A CMOS dual and quad analog switches combine low power operation with fast switching times and superior DC and AC switch characteristics. On resistance is less than 50Ω and is essentially constant over the analog signal range. Device specifications are ideal for battery powered circuitry.

These switches are available in a variety of formats as outlined below in the Pin Configurations section. The switch control logic inputs are fully TTL and CMOS compatible. Also featured are "break-before-make" switching and low charge injection.

Maxim's DG381-DG390 and DG381A-DG390A families are electrically compatible and pin compatible with the original manufacturer's devices. All devices will operate with power supplies ranging from ±5V to ±18V. Single supply operation is implemented by connecting V⁻ to GND.

Applications

- Portable Instruments
- Low Power Sample/Holds
- Power Supply Switching
- Programmable Gain Amplifiers
- SPDT and DPDT Functions
- Process Control and Telemetry

Features

- ◆ Monolithic Low Power CMOS
- ◆ Latch-Up Proof Construction
- ◆ Fully Compatible 2nd Source
- ◆ Low On Resistance, <50Ω
- ◆ Fast Switching Time
- ◆ V⁺ to V⁻ Analog Signal Range
- ◆ Single Supply Capability

Ordering Information

PART	TEMP. RANGE	PACKAGE
DG381C/D	0°C to +70°C	Dice
DG381CJ	0°C to +70°C	14 Lead Plastic DIP
DG381CWE	0°C to +70°C	16 Lead Wide SO
DG381CK	0°C to +70°C	14 Lead CERDIP
DG381BWE	-25°C to +85°C	16 Lead Wide SO
DG381BK	-25°C to +85°C	14 Lead CERDIP
DG381BA	-25°C to +85°C	10 Lead Metal Can
DG381AK	-55°C to +125°C	14 Lead CERDIP
DG381AA	-55°C to +125°C	10 Lead Metal Can

(Ordering Information is continued on last page.)

Pin Configurations

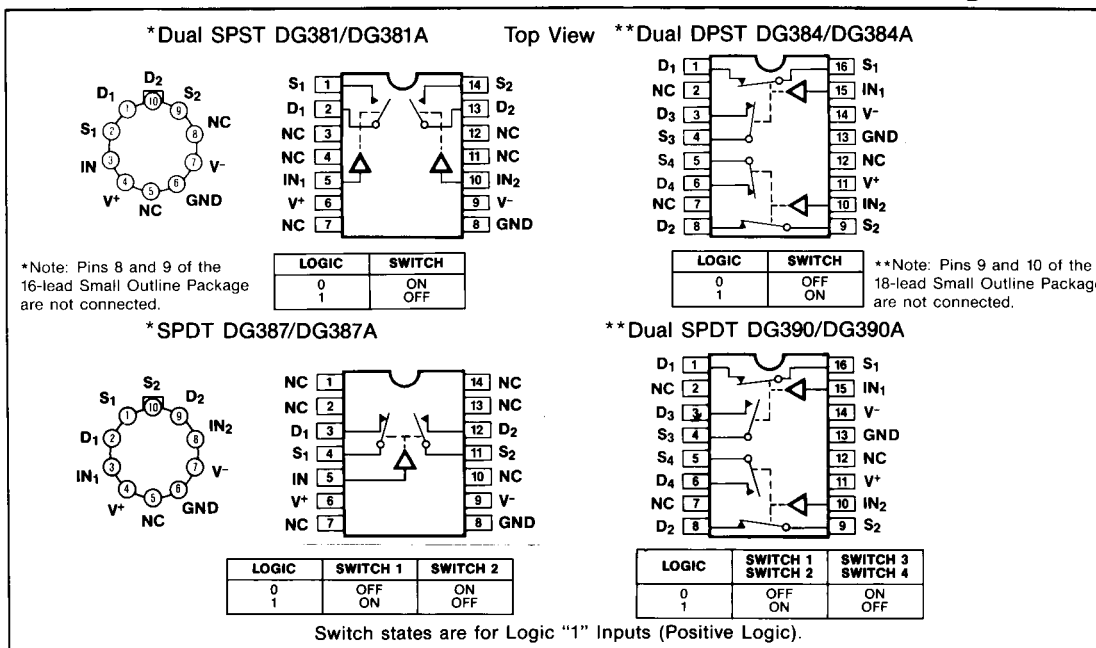

DG381(A)/DG384(A)/DG387(A)/DG390(A)



Maxim Integrated Products 1

For free samples & the latest literature: <http://www.maxim-ic.com>, or phone 1-800-998-8800

General Purpose CMOS Analog Switches

ABSOLUTE MAXIMUM RATINGS

Voltages Referenced to V ⁻	Operating Temperature (A Suffix)	-55°C to 125°C
V ⁺ (DG381-DG390)	(B Suffix)	-25°C to 85°C
V ⁺ (DG381A-DG390A)	(C Suffix)	0°C to 70°C
GND	Lead Temperature (Soldering 10 sec.)	+300°C
Digital Inputs, V _S , V _D (Note 1)	Power Dissipation*	
-4V to (V ⁺ + 4V) or	CerDip (K) (Derate 11mW/°C above 75°C)	825mW
30mA, whichever occurs first.	Plastic DIP (J) (Derate 6.5mW/°C above 25°C)	470mW
Current, Any Terminal Except S or D	Metal Can (A) (Derate 6mW/°C above 75°C)	450mW
30mA		
Continuous Current, S or D		
30mA		
(Pulsed at 1msec, 10% duty cycle max)		
100mA		
Storage Temperature (A & B Suffix)		
-65°C to 150°C		
(C Suffix)		
-65°C to 125°C		

Stresses listed under "Absolute Maximum Ratings" may be applied (one at a time) to devices without resulting in permanent damage. These are stress ratings only, and functional operation of the device at these or any other conditions above those indicated in the operational sections of the specifications is not implied. Exposure to absolute maximum ratings conditions for extended periods may affect device reliability.

ELECTRICAL CHARACTERISTICS (V⁺ = +15V, V⁻ = -15V, GND = 0V, T_A = 25°C, unless otherwise indicated)

PARAMETER	SYMBOL	TEST CONDITIONS	DG381-DG390A DG381A-DG390AA			DG381-DG390B/C DG381A-DG390AB/C			UNITS	
			MIN	TYP	MAX	MIN	TYP	MAX		
Analog Signal Range	V _{ANALOG}	I _S = 10mA, V _{in} = 0.8V or 4.0V	-15		15	-15		15	V	
SWITCH	Drain-Source ON Resistance	r _{DS(on)}	I _S = -10mA, V _D = 10V		30	50	30	50	Ω	
			I _S = 10mA, V _D = -10V		30	50	30	50		
	Source OFF Leakage Current	I _{S(off)}	V _{in} = 0.8V or 4.0V	V _S = 14V, V _D = -14V		0.1	1	0.1	5	nA
				V _S = -14V, V _D = 14V		-1	-0.1	-5	-0.1	
	Drain OFF Leakage Current	I _{D(off)}		V _S = -14V, V _D = 14V		0.1	1	0.1	5	
				V _S = 14V, V _D = -14V		-1	-0.1	-5	-0.1	
Drain ON Leakage Current	I _{D(on)}	V _D = V _S = 14V		0.1	1	0.1	5			
		V _D = V _S = -14V		-2	-0.1	-5	-0.1			
INPUT	Input Current/Voltage High	I _{INH}	V _{in} = 5.0V		-1	-0.001	-1	-0.001	μA	
			V _{in} = 15V		0.001	1	0.001	1		
	Input Current/Voltage Low	I _{INL}	V _{in} = 0V		-1	-0.001	-1	-0.001		
	Turn-ON Time	t _{on}	See Switching Time Test Circuit		150	300	150	300	ns	
	Turn-OFF Time	t _{off}			130	250	130	250		
	Break-Before-Make Interval	t _{on} -t _{off}	See Break-Before-Make Time Test Circuit DG387(A)/DG390(A) Only		50		50			
	Charge Injection	Q	C _L = 10nF, R _{gen} = 0Ω, V _{gen} = 0V		12		12		pC	
	Source OFF Capacitance	C _{S(off)}	f = 1MHz, V _{in} = 0.8V or 4.0V	V _S = 0V		14		14	pF	
	Drain OFF Capacitance	C _{D(off)}		V _D = 0V		14		14		
	Channel ON Capacitance	C _{D(on)} + C _{S(on)}		V _S = V _D = 0V		40		40		
	Input Capacitance	C _{in}		f = 1MHz		6		6		
					V _{in} = 0V	7		7		
	Off Isolation (Note 4)				V _{in} = 0V, R _L = 1kΩ	62		62	dB	
	Crosstalk (Channel to Channel)				V _S = 1 V _{RMS} , f = 500kHz	74		74		

(See Notes next page).

General Purpose CMOS Analog Switches

ELECTRICAL CHARACTERISTICS (Continued)

(V⁺ = +15V, V⁻ = -15V, GND = 0V, T_A = 25°C, unless otherwise indicated)

	PARAMETER	SYMBOL	TEST CONDITIONS	DG381-DG390A DG381A-DG390AA		DG381-DG390B/C DG381A-DG390AB/C		UNITS
				MIN (Note 2)	TYP (Note 3)	MAX (Note 3)	MIN (Note 2)	
SUPPLY	Positive Supply Current	I ⁺	V _{in} = 4V (One Input) (All Others = 0)	0.23	0.5	0.23	0.5	mA
	Negative Supply Current	I ⁻		-10	-0.001	-100	-0.001	
	Positive Supply Current	I ⁺	V _{in} = 0.8V (All Inputs)	0.001	10	0.001	100	μA
	Negative Supply Current	I ⁻		-10	-0.001	-100	-0.001	

ELECTRICAL CHARACTERISTICS (Over Temperature)

(V⁺ = +15V, V⁻ = -15V, GND = 0V, T_A = Over Temperature Range, unless otherwise indicated)

	PARAMETER	SYMBOL	TEST CONDITIONS	DG381-DG390A DG381A-DG390AA		DG381-DG390B/C DG381A-DG390AB/C		UNITS
				MIN (Note 2)	TYP (Note 3)	MAX (Note 3)	MIN (Note 2)	
SWITCH	Analog Signal Range	V _{ANALOG}	I _S = 10mA, V _{in} = 0.8V or 4.0V	-15	15	-15	15	V
	Drain-Source ON Resistance	r _{DS(on)}	V _{in} = 0.8V or 4.0V	I _S = -10mA, V _D = 10V	75	75	75	Ω
				I _S = 10mA, V _D = -10V	75	75	75	
	Source OFF Leakage Current	I _{S(off)}		V _S = 14V, V _D = -14V	100	100	100	nA
				V _S = -14V, V _D = 14V	-100	-100	-100	
				V _S = -14V, V _D = 14V	100	100	100	
	Drain OFF Leakage Current	I _{D(off)}		V _S = 14V, V _D = -14V	-100	-100	-100	
V _D = V _S = 14V				100	100	100		
Drain ON Leakage Current	I _{D(on)}	V _D = V _S = -14V	-200	-200	-200			
INPUT	Input Current/ Voltage High	I _{INH}	V _{in} = 5.0V	-1	-10	-10	μA	
			V _{in} = 15V	1	10	10		
	Input Current/ Voltage Low	I _{INL}	V _{in} = 0V	-1	-10	-10		
SUPPLY	Positive Supply Current	I ⁺	V _{in} = 4V (One Input) (All Others = 0)	1	1.5	1.5	mA	
	Negative Supply Current	I ⁻		-100	-200	-200		
	Positive Supply Current	I ⁺	V _{in} = 0.8V (All Inputs)	100	200	200	μA	
	Negative Supply Current	I ⁻		-100	-200	-200		

Note 1: Signals on S_x, D_x, or IN_x exceeding V⁺ or V⁻ will be clamped by internal diodes. Limit diode forward current to maximum current ratings.

Note 2: The algebraic convention whereby the most negative value is a minimum, and the most positive value is a maximum is used in this data sheet.

Note 3: Typical values are for DESIGN AID ONLY, not guaranteed nor subject to production testing.

Note 4: OFF isolation = 20 log $\frac{V_S}{V_D}$, V_S = input to OFF switch, V_D = Output.

General Purpose CMOS Analog Switches

Typical Operating Characteristics

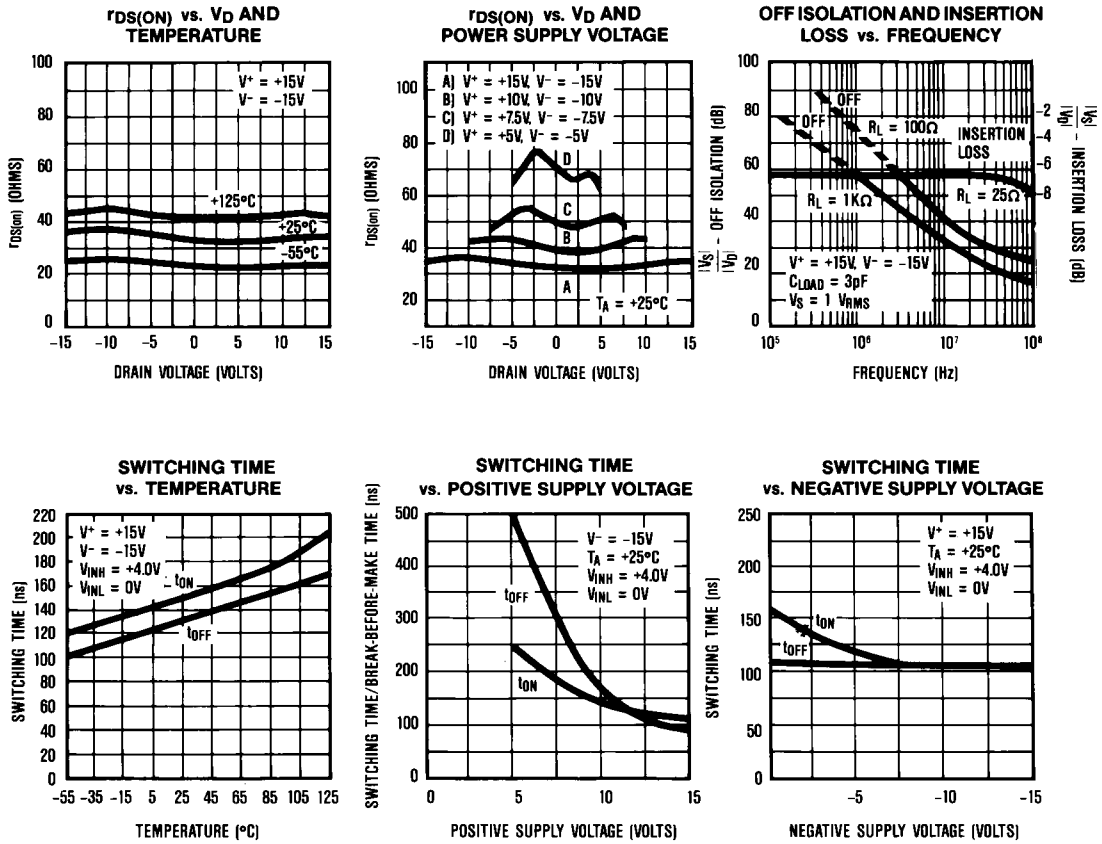

Test Circuits

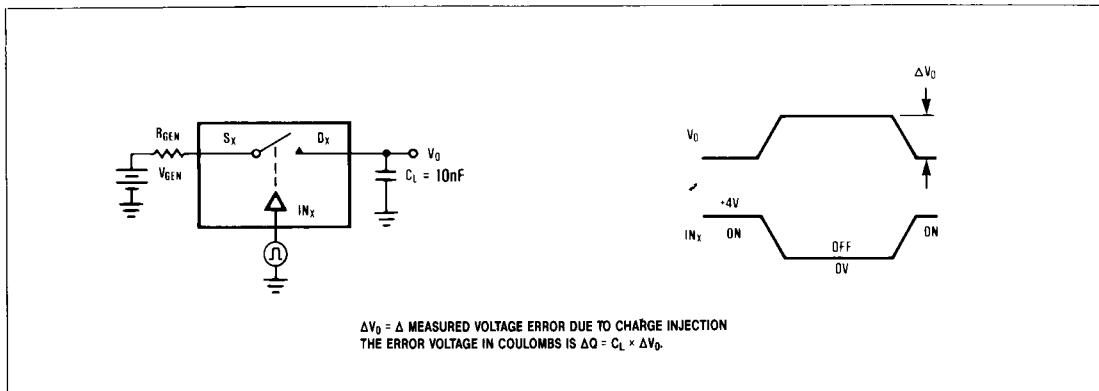

Figure 1. Charge Injection Test Circuit.

General Purpose CMOS Analog Switches

Test Circuits (Continued)

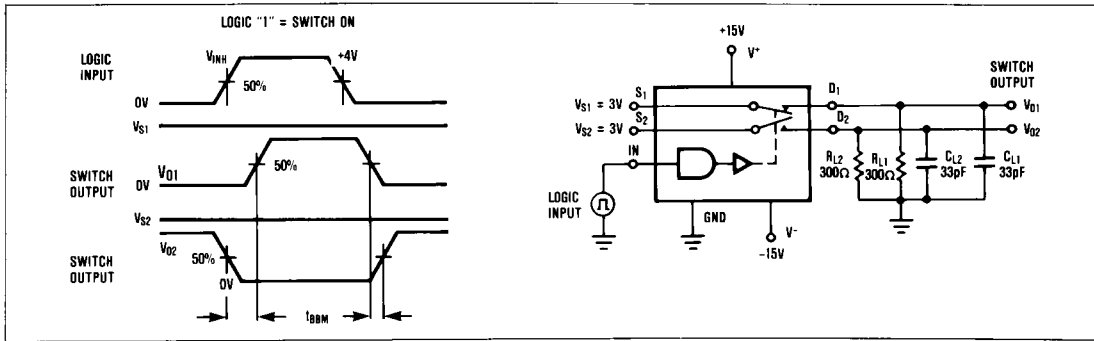

Figure 2. Break-Before-Make Time Test Circuit SPDT (DG387(A)/DG390(A)).

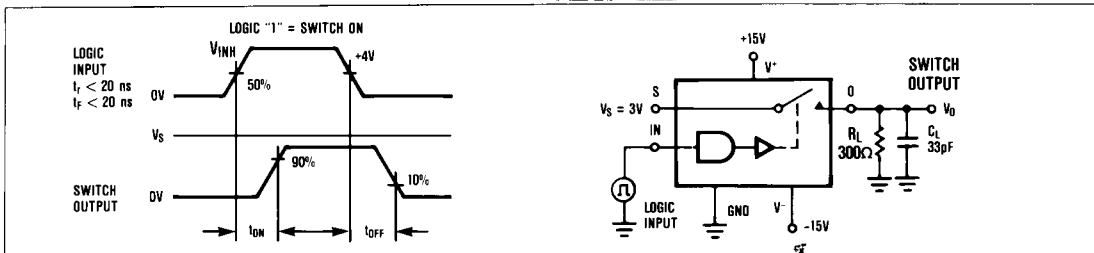

Figure 3. Switching Time Test Circuit.

Application Information

All DG381 family switches will operate with ± 5 to ± 15 V power supplies. They can also be used with single ended power supplies ranging from +10V to +30V where the V^- terminal is connected to ground. In either case analog signals ranging from V^+ to V^- can be switched.

The on resistance variation with analog signal and supply voltage is shown in the Typical Operating Characteristics graphs. The temperature coefficient of R_{ON} is typically 0.5%/°C. Typical on resistance matching from channel to channel is 10%. In addition, Table 1 outlines some typical parameters for single supply operation.

Table 1. Typical Single Supply Parameters

	V^+ SUPPLY VOLTAGE ($V^- = 0V$)			
	+10V	+15V	+20V	+30V
Switching Time ($R_L = 1k\Omega$)				
t_{ON}	190ns	150ns	110ns	70ns
t_{OFF}	40ns	40ns	40ns	40ns
On Resistance				
$V_{SIGNAL} = +1V$	71 Ω	51 Ω	42 Ω	31 Ω
$V_{SIGNAL} = V^+/2$	77 Ω	54 Ω	43 Ω	30 Ω
$V_{SIGNAL} = V^+$	84 Ω	63 Ω	54 Ω	43 Ω
Input Logic Levels	0.8V, 4.0V	0.8V, 4.0V	0.8V, 4.0V	0.8V, 4.5V

The charge injection test circuit is shown in Figure 1. Table 2 lists the typical injected charge for DG381 series switches with various input voltages.

Table 2. Charge Injection ($\pm 15V$ Supplies)

ANALOG INPUT	INJECTED Q
+10V	4pC
+5V	8pC
0V	12pC
-5V	8pC
-10V	5pC

DG381(A)/DG384(A)/DG387(A)/DG390(A)

DG381(A)/DG384(A)/DG387(A)/DG390(A)

General Purpose CMOS Analog Switches

Chip Topography

Ordering Information (continued)

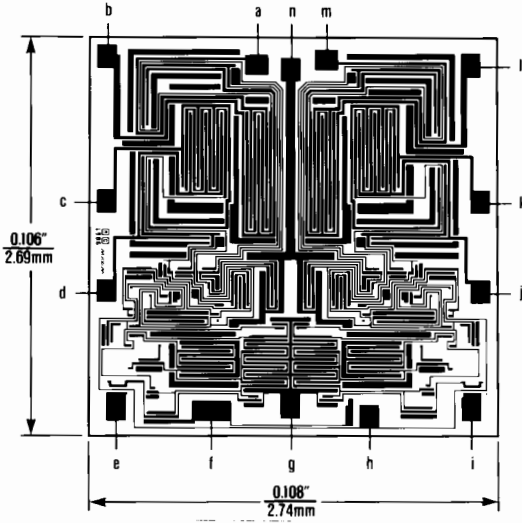

DIE PAD	DG381 DG381A	DG387 DG387A	DG384/390 DG384A/390A
a	N.C.	N.C.	S3
b	D1	D1	D3
c	D1	S1	D1
d	S1	IN1	S1
e	IN1	IN1	IN1
f	V ⁺	V ⁺	V ⁺
g	GND	GND	GND
h	V ⁻	V ⁻	V ⁻
i	IN2	GND	IN2
j	S2	V ⁻	S2
k	D2	S2	D2
l	D2	D2	D4
m	N.C.	N.C.	S4
n	V ⁺	V ⁺	V ⁺

Ordering Information (continued)

PART	TEMP. RANGE	PACKAGE
DG381AC/D	0°C to +70°C	Dice
DG381ACJ	0°C to +70°C	14 Lead Plastic DIP
DG381ACWE	0°C to +70°C	16 Lead Wide SO
DG381ACK	0°C to +70°C	14 Lead CERDIP
DG381ABWE	-25°C to +85°C	16 Lead Wide SO
DG381ABK	-25°C to +85°C	14 Lead CERDIP
DG381ABA	-25°C to +85°C	10 Lead Metal Can
DG384C/D	0°C to +70°C	Dice
DG384CJ	0°C to +70°C	16 Lead Plastic DIP
DG384CWE	0°C to +70°C	16 Lead Wide SO
DG384CK	0°C to +70°C	16 Lead CERDIP
DG384BWE	-25°C to +85°C	16 Lead Wide SO
DG384BK	-25°C to +85°C	16 Lead CERDIP
DG384AK	-55°C to +125°C	16 Lead CERDIP
DG384AC/D	0°C to +70°C	Dice
DG384ACJ	0°C to +70°C	16 Lead Plastic DIP
DG384ACWE	0°C to +70°C	16 Lead Wide SO
DG384ACK	0°C to +70°C	16 Lead CERDIP
DG384ABWE	-25°C to +85°C	16 Lead Wide SO
DG384ABK	-25°C to +85°C	16 Lead CERDIP
DG387C/D	0°C to +70°C	Dice
DG387CJ	0°C to +70°C	14 Lead Plastic DIP
DG387CWE	0°C to +70°C	16 Lead Wide SO
DG387CK	0°C to +70°C	14 Lead CERDIP
DG387BWE	-25°C to +85°C	16 Lead Wide SO

PART	TEMP. RANGE	PACKAGE
DG387BK	-25°C to +85°C	14 Lead CERDIP
DG387BA	-25°C to +85°C	10 Lead Metal Can
DG387AK	-55°C to +125°C	14 Lead CERDIP
DG387AA	-55°C to +125°C	10 Lead Metal Can
DG387AC/D	0°C to +70°C	Dice
DG387ACJ	0°C to +70°C	14 Lead Plastic DIP
DG387ACWE	0°C to +70°C	16 Lead Wide SO
DG387ACK	0°C to +70°C	14 Lead CERDIP
DG387ABWE	-25°C to +85°C	16 Lead Wide SO
DG387ABK	-25°C to +85°C	14 Lead CERDIP
DG387ABA	-25°C to +85°C	10 Lead Metal Can
DG390C/D	0°C to +70°C	Dice
DG390CJ	0°C to +70°C	16 Lead Plastic DIP
DG390CWE	0°C to +70°C	16 Lead Wide SO
DG390CK	0°C to +70°C	16 Lead CERDIP
DG390BWE	-25°C to +85°C	16 Lead Wide SO
DG390BK	-25°C to +85°C	16 Lead CERDIP
DG390AK	-55°C to +125°C	16 Lead CERDIP
DG390AC/D	0°C to +70°C	Dice
DG390ACJ	0°C to +70°C	16 Lead Plastic DIP
DG390ACWE	0°C to +70°C	16 Lead Wide SO
DG390ACK	0°C to +70°C	16 Lead CERDIP
DG390ABWE	-25°C to +85°C	16 Lead Wide SO
DG390ABK	-25°C to +85°C	16 Lead CERDIP

General Purpose CMOS Analog Switches

Package Information

DG381(A)/DG384(A)/DG387(A)/DG390(A)

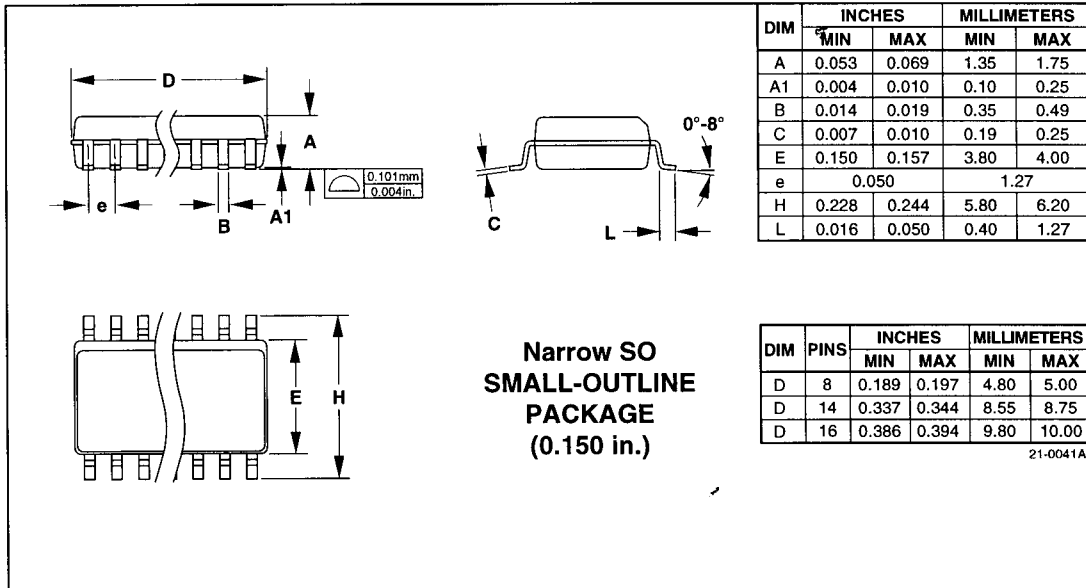
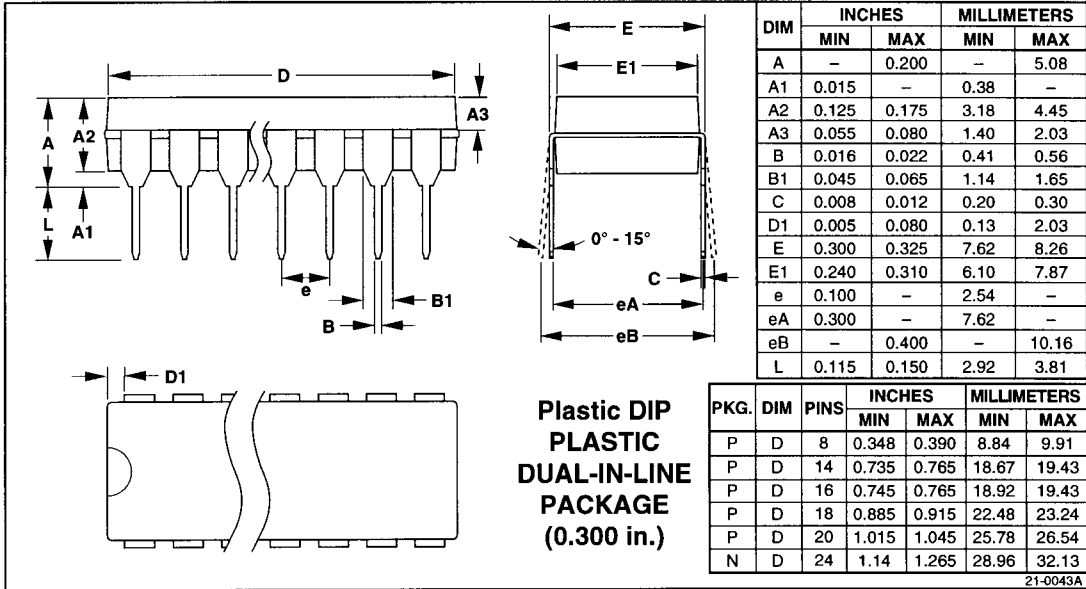

General Purpose CMOS Analog Switches

DG381(A)/DG384(A)/DG387(A)/DG390(A)

Package Information (continued)

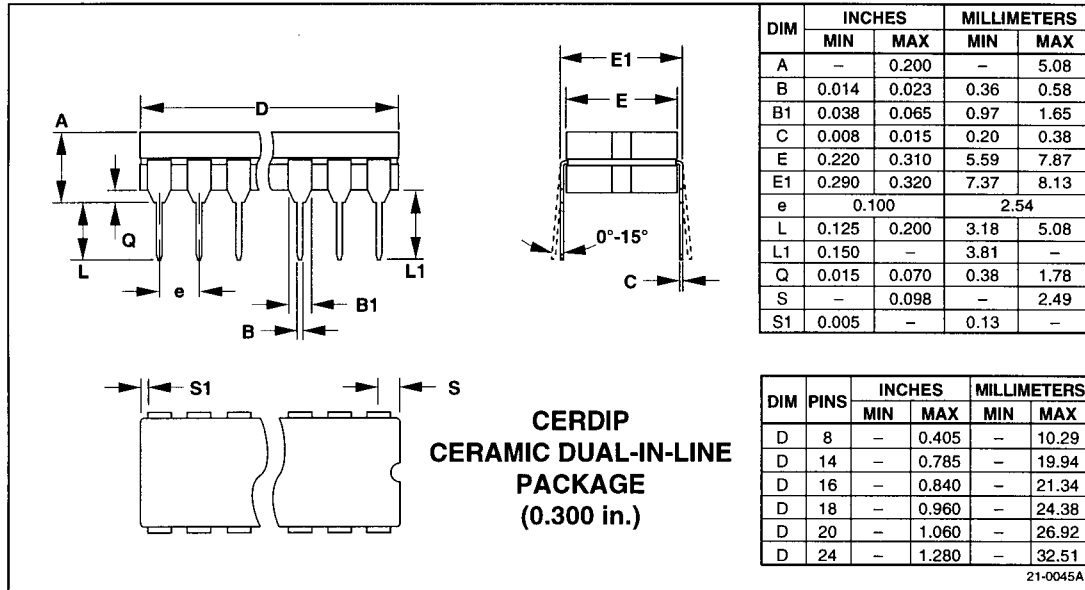

Maxim cannot assume responsibility for use of any circuitry other than circuitry entirely embodied in a Maxim product. No circuit patent licenses are implied. Maxim reserves the right to change the circuitry and specifications without notice at any time.

8 **Maxim Integrated Products, 120 San Gabriel Drive, Sunnyvale, CA 94086 (408) 737-7600**

© 1995 Maxim Integrated Products

Printed USA

MAXIM is a registered trademark of Maxim Integrated Products.

[DG381A](#)

Part Number Table

Notes:

1. See the [DG381A QuickView Data Sheet](#) for further information on this product family or download the [DG381A full data sheet](#) (PDF, 312kB).
2. Other options and links for purchasing parts are listed at: <http://www.maxim-ic.com/sales>.
3. [Didn't Find What You Need?](#) Ask our applications engineers. Expert assistance in finding parts, usually within one business day.
4. Part number suffixes: T or T&R = tape and reel; + = RoHS/lead-free; # = RoHS/lead-exempt. More: See [full data sheet](#) or [Part Naming Conventions](#).
5. * Some packages have variations, listed on the drawing. "PkgCode/Variation" tells which variation the product uses.

Part Number	Free Sample	Buy Direct	Package: TYPE PINS SIZE DRAWING CODE/VAR *	Temp	RoHS/Lead-Free? Materials Analysis
DG381AC/D					RoHS/Lead-Free: No
DG381ACK			Ceramic DIP;14 pin;.300" Dwg: 21-0045A (PDF) Use pkgcode/variation: J14-3*	0C to +70C	RoHS/Lead-Free: No Materials Analysis
DG381ABK			Ceramic DIP;14 pin;.300" Dwg: 21-0045A (PDF) Use pkgcode/variation: J14-3*	-20C to +85C	RoHS/Lead-Free: No Materials Analysis

DG381AAK	Ceramic DIP;14 pin;.300" Dwg: 21-0045A (PDF) Use pkgcode/variation: J14-3*	-55C to +125C	RoHS/Lead-Free: No Materials Analysis
DG381AAK/883B	Ceramic DIP;14 pin;.300" Dwg: 21-0045A (PDF) Use pkgcode/variation: J14-3*	-55C to +125C	RoHS/Lead-Free: No Materials Analysis
DG381ACA	Gold Can -TO;10 pin; Dwg: 21-0023A (PDF) Use pkgcode/variation: G100-10*	0C to +70C	RoHS/Lead-Free: No Materials Analysis
DG381ABA	Gold Can -TO;10 pin; Dwg: 21-0023A (PDF) Use pkgcode/variation: G100-10*	-20C to +85C	RoHS/Lead-Free: No Materials Analysis
DG381AAA	Gold Can -TO;10 pin; Dwg: 21-0023A (PDF) Use pkgcode/variation: G100-10*	-55C to +125C	RoHS/Lead-Free: No Materials Analysis
DG381AAA/883B	Gold Can -TO;10 pin; Dwg: 21-0023A (PDF) Use pkgcode/variation: G100-10*	-55C to +125C	RoHS/Lead-Free: No Materials Analysis
DG381ACJ	PDIP;14 pin;.300" Dwg: 21-0043D (PDF) Use pkgcode/variation: P14-4*	0C to +70C	RoHS/Lead-Free: No Materials Analysis
DG381ACJ+	PDIP;14 pin;.300" Dwg: 21-0043D (PDF) Use pkgcode/variation: P14+4*	0C to +70C	RoHS/Lead-Free: Yes Materials Analysis
DG381ACWE	SOIC;16 pin;.300" Dwg: 21-0042B (PDF) Use pkgcode/variation: W16-2*	0C to +70C	RoHS/Lead-Free: No Materials Analysis
DG381ACWE-T	SOIC;16 pin;.300" Dwg: 21-0042B (PDF) Use pkgcode/variation: W16-2*	0C to +70C	RoHS/Lead-Free: No Materials Analysis
DG381ACWE+	SOIC;16 pin;.300" Dwg: 21-0042B (PDF) Use pkgcode/variation: W16+2*	0C to +70C	RoHS/Lead-Free: Yes Materials Analysis

DG381ACWE+T

SOIC;16 pin;300"

0C to +70C

RoHS/Lead-Free: [Yes](#)

Dwg: [21-0042B](#) (PDF)

[Materials Analysis](#)

Use pkgcode/variation: W16+2*

[Didn't Find What You Need?](#)

[CONTACT US: SEND US AN EMAIL](#)

Copyright 2007 by Maxim Integrated Products, Dallas Semiconductor • [Legal Notices](#) • [Privacy Policy](#)