

# 承 認 書

## SPECIFICATION FOR APPROVAL

*客戶名稱 <b>Customer name</b>	: 立创
*產品名稱 <b>Product Description</b>	: DIN插座
*產品型號 <b>Product part number</b>	: DIN-603
*客戶料號 <b>Customer's material number</b>	:
*數量 <b>Quantity</b>	:
*日期 <b>Date</b>	:

供應商負責人簽名		客戶負責人確認簽回	
製作人	莫丽琴	承認人	
審核	郭远维	審核	
批准	王瑞宝	批准	

皓宇(香港)有限公司  
HAOYU (HONG KONG) LIMITED  
东莞市弘皓电子有限公司  
DONGGUAN HOOYA ELECTRONICS CO. LTD  
東莞市石碣鎮四村第一工業區  
Sicun 1st Industrial park, Sicun,  
Shijie Town, Dongguan  
電 話 : (86) 769-82310511-2  
Tel No  
傳 真 : (86) 769-82310510  
Fax No  
郵 箱 : [haoyu888@21cn.com](mailto:haoyu888@21cn.com)  
E - mail

核 准 :  
Approved



皓宇(香港)有限公司  
HAOYU (HONG KONG) LIMITED

---

## 索引(INDEX)

1)承认书首页(HOME PAGE)-----	1
2) 索引 (INDEX) -----	2
3)规格书(SPECIFICATION)-----	3-5
4)工程图(DRAWING) -----	

皓宇(香港)有限公司 HAOYU (HONG KONG) LIMITED	文件編號	HY-WI-32
	發行日期	2019-9-9
SPECIFICATION 承認書	第 B-3 版	第 1 頁 共 3 頁

SERIES 產品系列	DIN SOCKET DIN 端子	TYPE 產品型號	環保
DRAWN 設計	Li Yue Xin	APVD 審批	Li Yue Xin
1 · RATING (額定值): DC12V 2A	CONSTRUCTION DIMENSION 結構尺寸		Apply to the appended drawing. 符合附加圖紙
2 · OPERATING TEMPERATURE RANGE 操作溫度範圍	-25°C~85°C	PRESERVATIVE TEMPERATURE RANGE 儲存溫度範圍	5°C~40°C
ITEM 項目	TEST CONDITIONS 測試條件	SPECIFICATIONS 規格	
3 · ELECTRICAL PERFORMANCE (電氣性能規格):			
3A	CONTACT RESISTANCE 接觸電阻	MEASURED BY THE CONTACT RESISTANCE APPARATUS OR mΩ METER AT 0.1A DC5V .THE RESULT IS THE AVERAGE OF5 SUCCESSIVE MEASUREMENTS. 在電壓為 5V，直流電流為 0.1A 時，用接觸電阻測量儀或毫歐表測量。結果取測量 5 次後的平均值。	50mΩ max 50 毫歐以下
3B	INSULATION RESISTANCE 絕緣阻抗	A VOLTAGE OF250V DC SHALL BE APPLIED FOR 1 MIN. AFTER WHICH MEASUREMENT SHALL BE MADE. BETWEEN TERMINALS BETWEEN INDIVIDUAL TERMINALS AND FRAME 輸入 250V DC 電壓 1 分鐘,按以下接觸方法測試 (1) 接觸端子之間 (2) 插座本體與端子之間	100MΩ min 100 兆歐以上.
3C	DIELECTRIC STRENGTH 耐電壓	A VOLTAGE OF250V AC SHALL BE APPLIED FOR 1 MIN. AFTER WHICH MEASUREMENT SHALL BE MADE. BETWEEN TERMINALS BETWEEN INDIVIDUAL TERMINALS AND FRAME 輸入 250V AC 電壓 1 分鐘,按以下接觸方法測試 (3) 接觸端子之間 (4) 插座本體與端子之間	WITHOUT DAMAGE TO PARTS ARCING OR BREAKDOWN ETC 沒有損傷 變形絕緣破壞等異常.
4.MECHANICAL PERFORMANCE(機械性能規格)			
4A	INSERTION AND WITHDRAW FORCE 插拔力	Being measure at across spring piece and across matching plug for ergometer 用測力計在插頭與彈片之間進行測量。(空插三次後測試)	Insertion and extraction force 5-35N 插拔力 5-35 牛頓
4B	TERMINAL STRENGTH 端子強度	A STATIC LOAD OF 5 N(500gf) SHALL BE APPLIED TO THE TIP OF THE TERMINALS FOR 60 SEC. IN ANY DIRECTION 在任意一個方向的先端上加力度 5N(500gf)60 秒鐘	ELECTRICAL CHARACTERISTICS SHALL BE SATISFIED.WITHOUT DAMAGE OR EXCESSIVE LOOSEN-ESS OF ACTUATOR 在端子中沒有裂開\鬆動等異常 滿足於電器性能.

皓宇(香港)有限公司 HAOYU (HONG KONG) LIMITED	文件編號	HY-WI-32
	發行日期	2019-9-9
SPECIFICATION 承認書	第 B-3 版	第 2 頁 共 3 頁

5 · DURABILITY (持久性)			
5A	SOLDERABILITY TEST 可焊性試驗	THE TOP OF THE TERMINALS SHALL BE DIPPED 2mm IN THE SOLDER BATH OF $245 \pm 5^{\circ}\text{C}$ FOR 5S+0/-0.5S . 端子頂部被浸入焊錫池中 2mm 深，溫度為 $245 \pm 5^{\circ}\text{C}$ ，時間為 5 秒+0/-0.5 秒。	THE AREA OF SOLDERABILITY SHOULD BE OVER 95% 焊接面積要有 95%以上
5B	RESISTANCE TO SOLDERING HEAT TEST 耐焊性試驗	Wave-soldering is to be performed within $5 \pm 0.5$ seconds at $260 \pm 5^{\circ}\text{C}$ 波峰焊接溫度 $260 \pm 5^{\circ}\text{C}$ 時間 $5 \pm 0.5$ 秒。 Hand welding to be performed within 3 seconds at $380 \pm 5^{\circ}\text{C}$ . 手工焊接溫度為 $380 \pm 5^{\circ}\text{C}$ ，時間為 $3 \pm 0.5$ 秒。 注：本產品只適合用手焊、波峰焊。	WITHOUT DEFORMATION OF CASE OR EXCESSIVE LOOSENESS OF TERMINALS ELECTRICAL CHARACTERISTICS SHALL BE SATISFIED. 本體無變形，能滿足於機械、電氣性能。
5C	LIFE TEST. 壽命試驗	WITHOUT LOAD (IT IS TESTED BY MACHINE ,ACTING FORCE MUST BE PARALLEL TO THE WAY OF PUSHING) : AN ACTUATOR SHALL BE SUBJECT TO 5000 CYCLES AT A SPEED OF 30 CYCLES FOR 1 MIN 無負荷（只限於機器測試，作用力平行於插拔方向）： 操作者以每分鐘 30 次的頻率作 5000 回之無負荷測試。	(1) CONTACT RESISTANCE SHALL BE $200\text{m}\Omega$ max (2) MECHANICAL AND ELECTRICAL CHARACTERISTICS SHALL BE SATISFIED . (1) 接觸電阻不能超於 $200\text{m}\Omega$ (2) 其他滿足於機械電器性能。
5D	HEAT TEST. 耐熱試驗	$85 \pm 2^{\circ}\text{C}$ FOR 96 HOURS AFTER TEST KEEP IN NORMAL CONDITION FOR 30 MINUTES. 在 $85 \pm 2^{\circ}\text{C}$ 環境中放 96 小時，再放在正常環境中 30 分鐘後進行測試。	THERE SHALL BE NO DAMAGE ON APPEARANCE . MECHANICAL AND ELECTRICAL CHARACTERISTICS SHALL BE SATISFIED 外觀無異常，滿足於機械，電器性能。
5E	HUMIDITY TEST. 耐濕試驗	$40 \pm 2^{\circ}\text{C}$ 90-96%RH FOR 96 HOURS, TEST AFTER KEEPING IN NORMAL CONDITION FOR 30 MIN. 在 $40 \pm 2^{\circ}\text{C}$ 90-96%RH 環境中放 96 小時，再放在正常環境中，30 分鐘後進行測試。	
5F	COLD TEST. 耐冷試驗	At $-40 \pm 2^{\circ}\text{C}$ for 48 HRS. AFTER TEST KEEP IN NORMAL CONDITION FOR 30 MIN. 在 $-40 \pm 2^{\circ}\text{C}$ 環境中放 48 小時，再置於正常環境中 30 分鐘後進行測試。	
5G	SALT SPRAY TEST 噴霧試驗	AT 5% NaCl LIQUOR FOR 24 HOURS, AFTER WASHING, KEEP IN NORMAL CONDITION FOR 30 MIN. 5%的 NaCl 溶液中噴霧 24 小時，用水清洗並在室溫下放置 30 分鐘	WITHOUT EXCESSIVE CORROSION OR CRACK IN APPEARANCE (EXCEPT THE RIVETING POSITION) 表面無明顯腐蝕或鍍層脫落現象（铆压位置除外）

皓宇(香港)有限公司 HAOYU (HONG KONG) LIMITED	文件編號	HY-WI-32
	發行日期	2019-9-9
SPECIFICATION 承認書	第 B-3 版	第 3 頁 共 3 頁

6 · 注意事項 ( APPLICATION NOTES: )

1、在耐焊接過程中,不得把松香等絕緣、有腐蝕性物質浸入產品內。

( ROSIN AND OTHER INSULATING AND CAUSTIC MATERIAL CAN NOT BE DIPPED INTO THE ROCKET DURING SOLDERING. )

2、產品焊接後不能用氣槍吹或用溶劑沖洗。

( PRODUCTS CAN NOT BE BLOWN WITH AIR GUN OR CLEANED WITH A SOLVENT AFTER SOLDERING. )

3、產品焊接前各零件不能被溶化。

( ALL PARTS OF THE PRODUCTS CAN NOT BE DISSOLVED BEFORE SOLDERING. )

4、避免儲藏於高溫、潮濕及腐蝕的場所。

( AVOID STORING THE PRODUCTS IN A PLACE AT HIGH TEMPERATURE, HIGH HUMIDITY AND IN CORROSIVE GASES. )

5、貯存期限:自發貨之日起,貯存期不超過 180 天, 且产品需要 PE 袋密封保存。

( SHELF LIFE IS LESS THAN 180 DAYS SINCE THE GOODS WARE SENT OUT FROM OUR FACTORY. PRODUCTS NEED TO SEAL PRESERVATION PE BAG. )

6、本產品如有不良事件, 望廠家及時回饋, 以便及時記錄、查核、改善、跟蹤。

( PLEASE FEEL FREE TO REPORT TO US IF YOU DISCOVER THE INFERIOR GOODS, SO THAT WE CAN TAKE NOTE, CHECK, TRACK AND IMPROVE THEM. THANKS. )

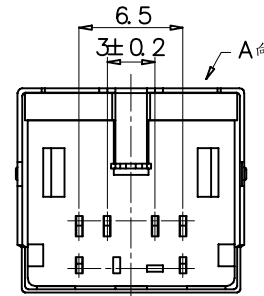
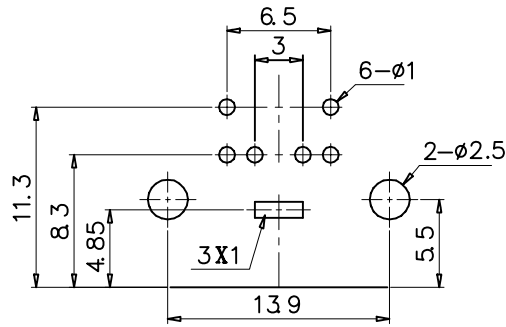
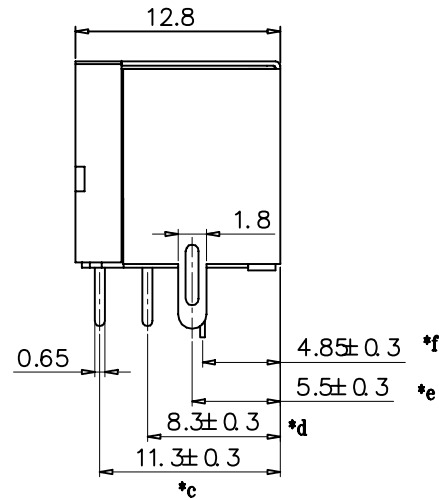
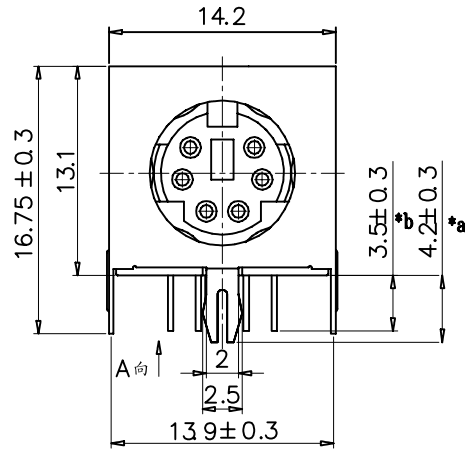

P.C.B. LAYOUT

10	铜后盖	BRASS	1	Sn-PLATED
9	铜前盖	BRASS	1	Sn-PLATED
8	右中针	BRASS	1	Sn-PLATED
7	左中针	BRASS	1	Sn-PLATED
6	右长针	BRASS	1	Sn-PLATED
5	左长针	BRASS	1	Sn-PLATED
4	右短针	BRASS	1	Sn-PLATED
3	左短针	BRASS	1	Sn-PLATED
2	盖子	PBT	1	
1	基座	PBT	1	
NO.	PART NAME	MATERIAL	QTY	FINISHING

TOLERANCE UNLESS SPECIFIED						
UP TO 5mm: ±0.1	ANGULAR	A1	2018.3.29	更新图面		
ABOVE 5mm: ±0.2	±1°	NO	DATE	REVISIONS	BY	APPD
TITLE: DIN JACK			UNIT : MM	ROHS	DWN	
MODEL: DIN-603			SCALE: 1:1	COMPLIANT	CHK'D	
 <b>HAOYU(HONGKONG)LIMITED</b> 皓宇(香港)有限公司				APPD		
				PRO.AGL:		