

G-Switch USB-C Specification:

1. Current rated: 5A on vbus/1.25A on vconn/0.25A on other
Voltage rating: 24V AC
2. Withstanding voltage: 100V AC/minute
3. Contact resistance: 40mΩ Max
4. Insulation resistance: 100MΩ Min
5. Operating temperature: -40°C ~ +85°C
6. Mating force: 5N~20N
7. Unmating force: 8N~20N
8. Durability cycle: 10,000 cycles
9. Waterproof grade: IP-X8

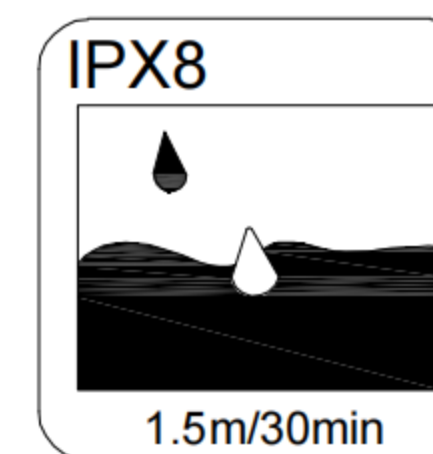
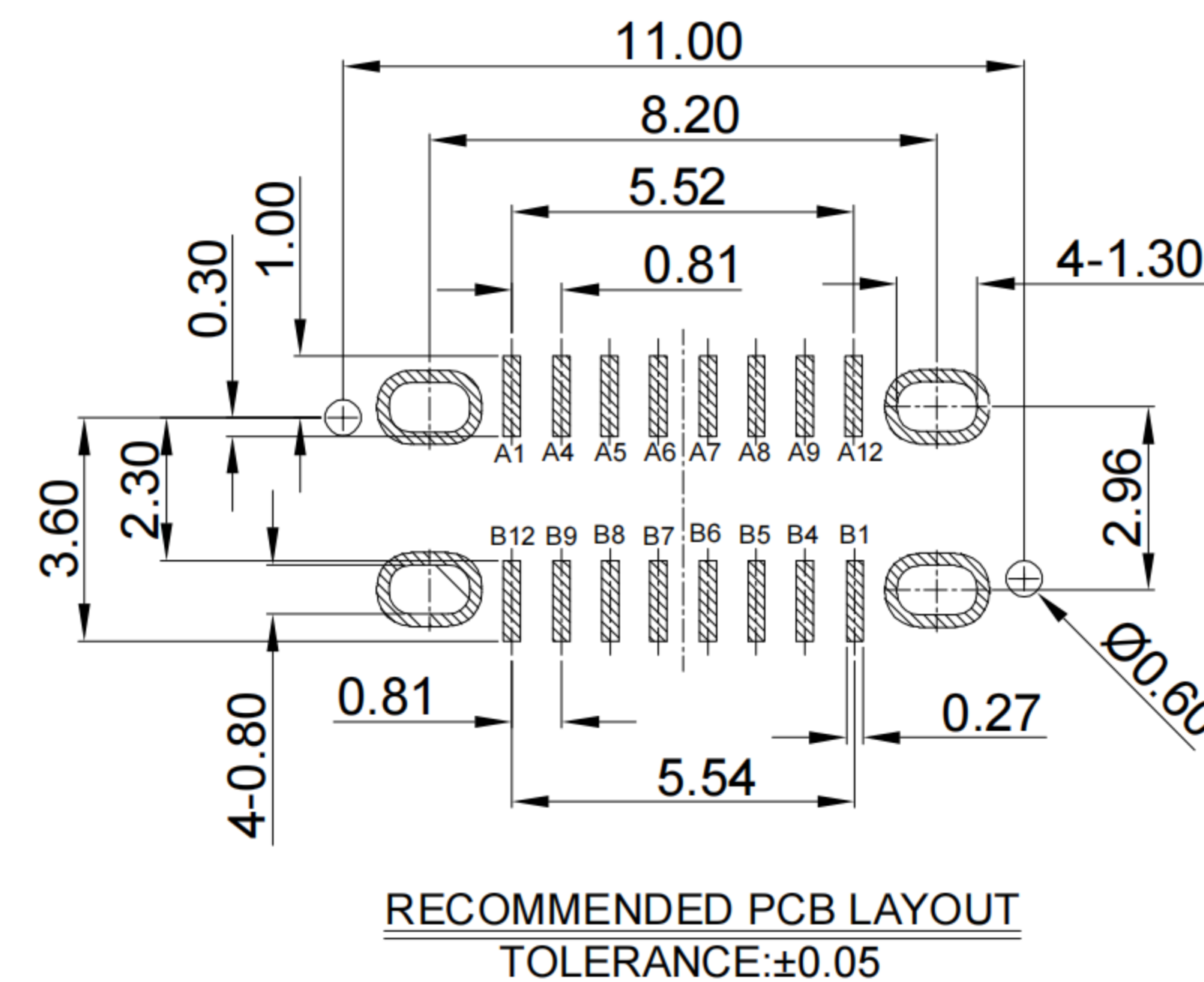
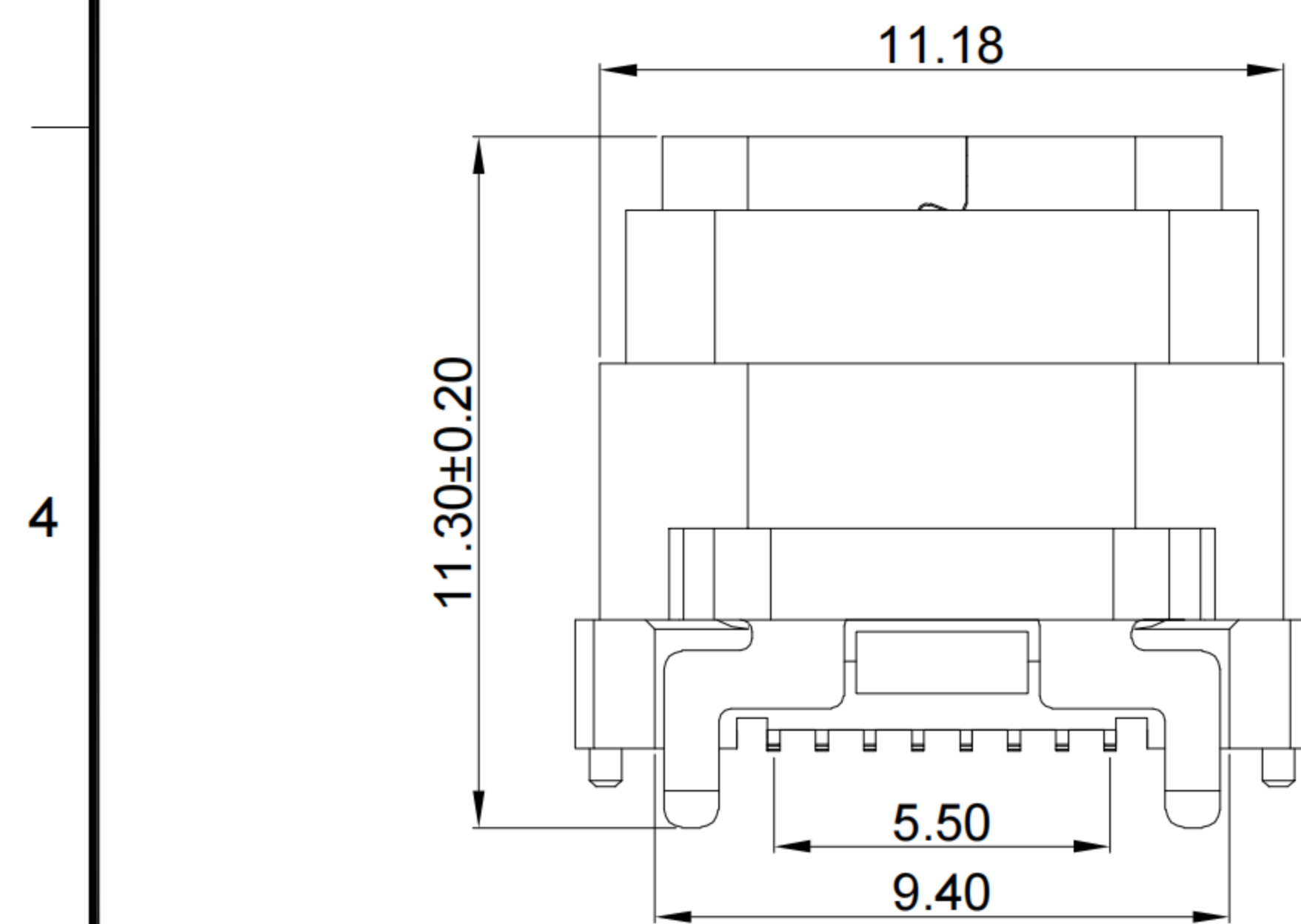

A1	A2	A3	A4	A5	A6	A7	A8	A9	A10	A11	A12
GND			VBUS	CC1	D+	D-	SBU1	VBUS			GND
First			First	Second	Second	Second	Second	First			First

B12	B11	B10	B9	B8	B7	B6	B5	B4	B3	B2	B1
GND			VBUS	SBU2	D-	D+	CC2	VBUS			GND
First			First	Second	Second	Second	Second	First			First

1	CAP	HIGH TEMPERATURE PLASTIC	BLACK
2	SHELL	STAINLESS STEEL	NI PLATED
3	MID PLATE	STAINLESS STEEL	--
4	HOUSING	HIGH TEMPERATURE PLASTIC	Black UL 94 V-0
5	TERMINALS	COPPER ALLOY	Au PLATING ON CONTACT AREA
NO.	PARTS	MATERIAL	REMARKS



SCALE: 1:1 UNIT: mm
SIZE: A4

Title: Vertical Type-c 16P Female
SMT H=10.0mm

Unless otherwise
General Tolerance:
X.x ±0.30
X.xx ±0.20
X.xxx ±0.10
X.x° ±3°
X.xx° ±2°

Molde Code: GT-USB-7096DA

DRAWN	CHECKED	APPROVED	DATE
Xia	Chen	Chen	2023.02.01



REV: A0 SHEET: 1/2

1

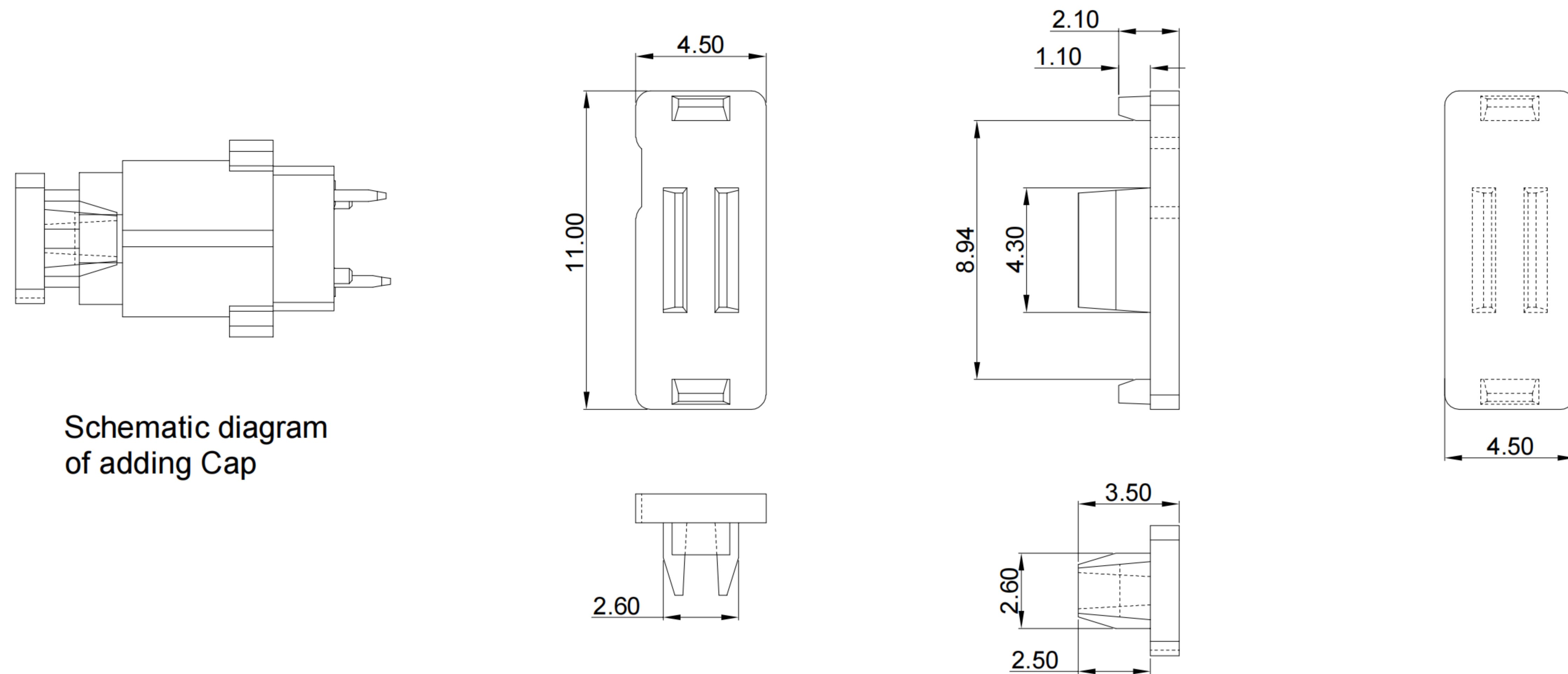

Schematic diagram of adding Cap

2



- G-Switch USB-C Specification:**
- 1.Current rated: 5A on vbus/1.25A on vconn/0.25A on other
Voltage rating: 24V AC
 - 2.Withstanding voltage: 100V AC/minute
 - 3.Contact resistance: 40mΩ Max
 - 4.Insulation resistance: 100MΩ Min
 - 5.Operating temperature: -40°C ~ +85°C
 - 6.Mating force: 5N~20N
 - 7.Unmating force: 8N~20N
 - 8.Durability cycle:10,000 cycles
 - 9.Waterproof grade: IP-X8

3

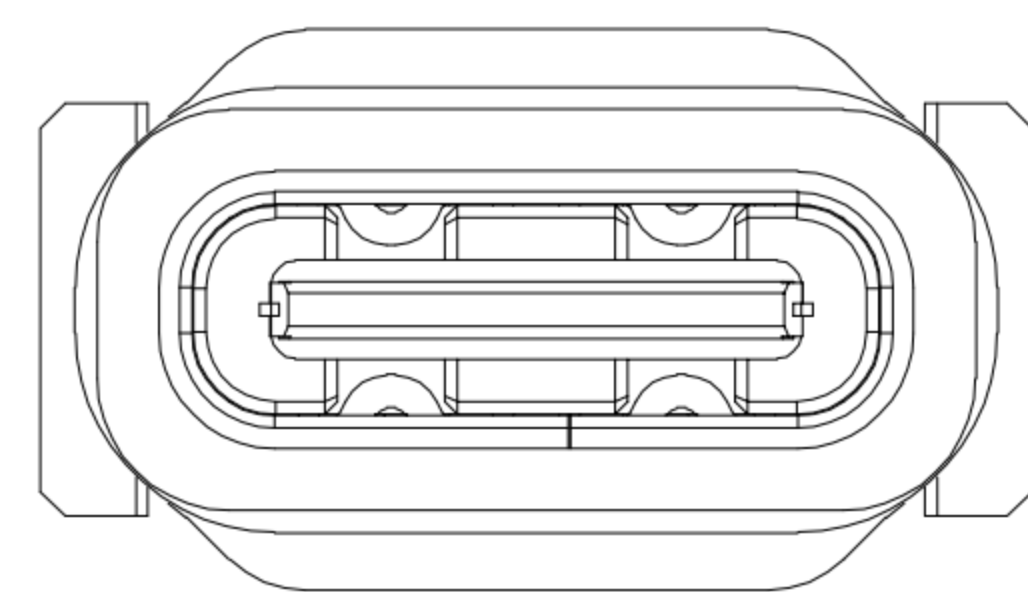

Schematic diagram of adding water-proof ring

4

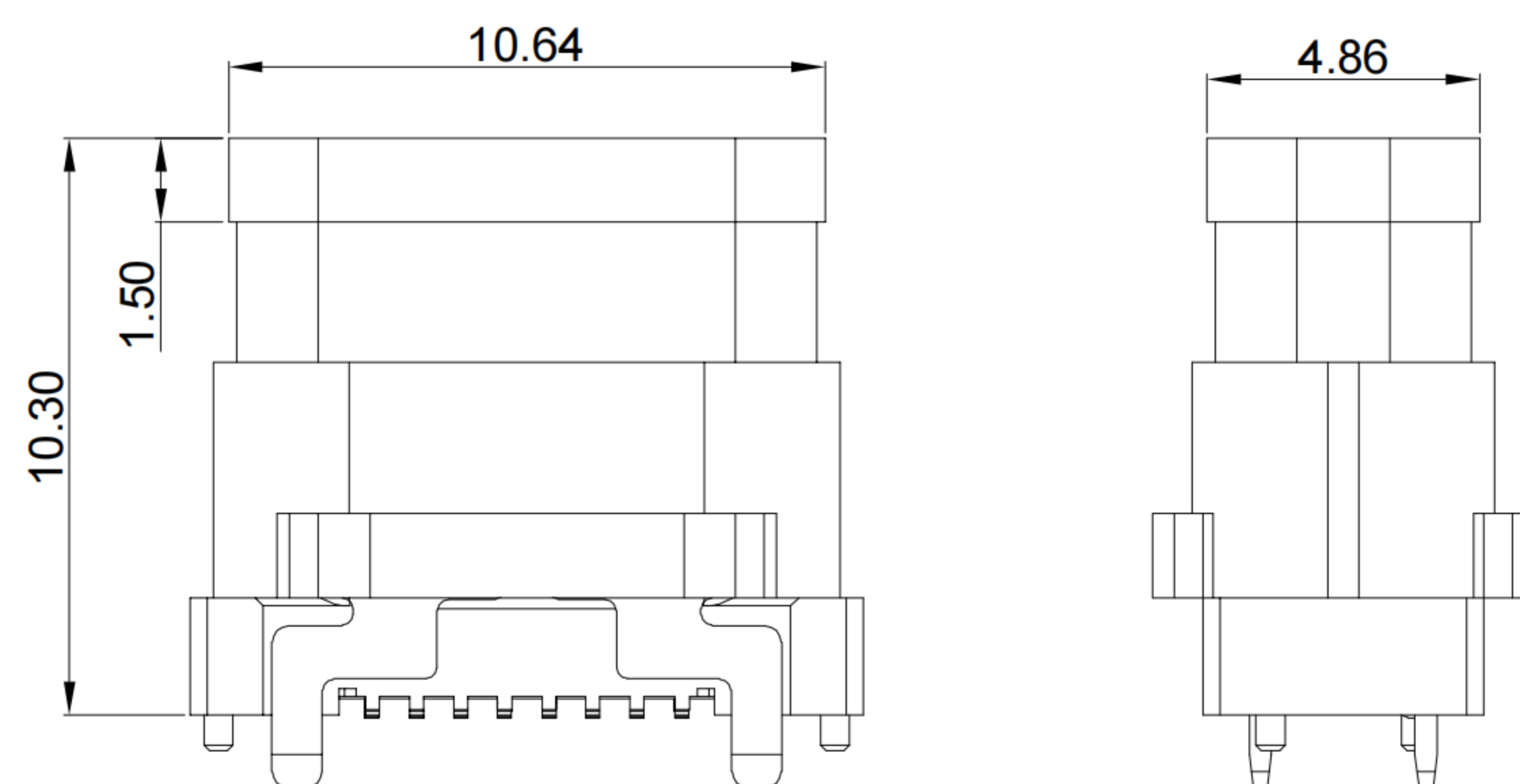

A1	A2	A3	A4	A5	A6	A7	A8	A9	A10	A11	A12
GND			VBUS	CC1	D+	D-	SBU1	VBUS			GND
First			First	Second	Second	Second	Second	First			First
B12	B11	B10	B9	B8	B7	B6	B5	B4	B3	B2	B1
GND			VBUS	SBU2	D-	D+	CC2	VBUS			GND
First			First	Second	Second	Second	Second	First			First

5

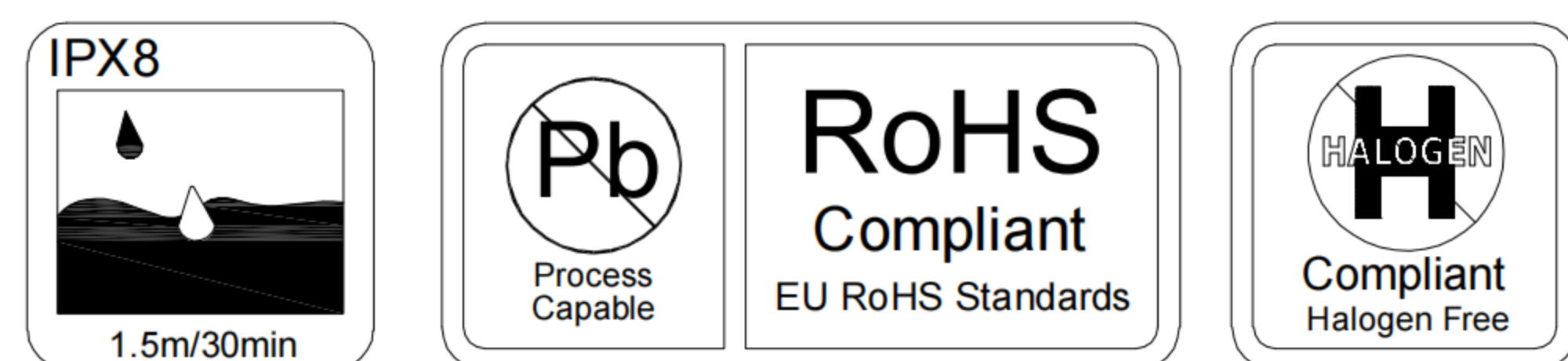

SCALE: 1:1	UNIT: mm	Title: Vertical Type-c 16P Female SMT H=10.0mm	
SIZE: A4		Molde Code: GT-USB-7096DA	
Unless otherwise General Tolerance:		DRAWN	CHECKED
X.x	±0.30	Xia	Chen
X.xx	±0.20		
X.xxx	±0.10		
X.x°	±3°		
X.xx°	±2°		
		APPROVED	DATE
		Chen	2023.02.01

