

LMP8272

High Common Mode, Gain of 14, Precision Voltage Difference Amplifier

General Description

The LMP8272 is a fixed gain differential amplifier with a $-2V$ to $27V$ input common mode voltage range and a supply voltage range of $4.75V$ to $5.5V$. The LMP8272 is part of the LMP™ precision amplifier family which will detect, amplify, and filter small differential signals in the presence of high common mode voltages. The gain is fixed at 14 and is adequate to drive an ADC to full scale in most cases. This fixed gain is achieved in two separate stages, a pre-amplifier with gain of $+7$ and a second stage amplifier with a gain of $+2$. The internal signal path between these two stages is brought out on two pins that provide a connection for a filter network.

The LMP8272 will operate with reduced specifications over the extended common mode input voltage range of $-2V$ to $36V$. This feature makes the device suitable for applications with load dump in automotive systems.

Features

Typical Values, $T_A = 25^\circ C$

■ Input offset voltage	± 1 mV max
■ TCV_{OS}	± 15 $\mu V/^\circ C$ max
■ CMRR	80 dB min
■ Extended CMVR	$-2V$ to $36V$
■ Output voltage swing	Rail-to-rail
■ Bandwidth	80 kHz
■ Operating temperature range (ambient)	$-40^\circ C$ to $125^\circ C$
■ Supply voltage	$4.75V$ to $5.5V$
■ Supply current	1 mA

Applications

- Fuel injection control
- High and low side driver configuration current sensing
- Power management systems

Typical Application

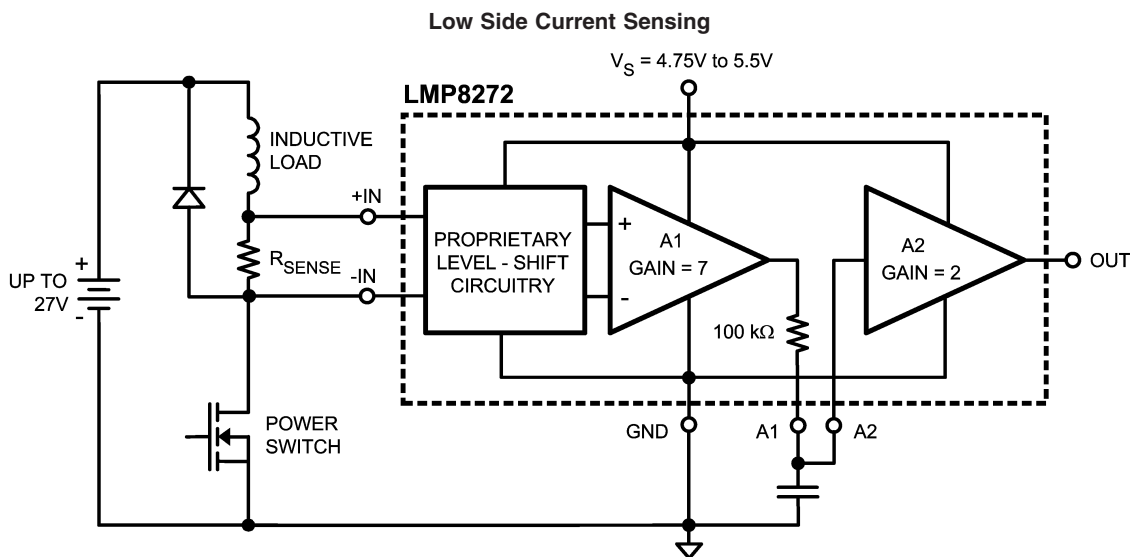

Absolute Maximum Ratings (Note 1)

If Military/Aerospace specified devices are required, please contact the National Semiconductor Sales Office/Distributors for availability and specifications.

ESD Tolerance (Note 2)

Human Body Model

For input pins only $\pm 4000V$ For All other pins $\pm 2000V$

Machine Model 200V

Supply Voltage (V_S - GND) 5.75V

Voltage on +IN and -IN -5V to 42V

Transient (400 ms) -7V to 45V

Storage Temperature Range -65°C to $+150^\circ\text{C}$

Junction Temperature (Note 3)

 $+150^\circ\text{C}$ max

Soldering Information

Infrared or Convection (20 sec) 235°C Wave Soldering Lead Temp. (10 sec) 260°C **Operating Ratings** (Note 1)

Temperature Range

Packaged Devices (Note 3) -40°C to $+125^\circ\text{C}$ Supply Voltage (V_S - GND) 4.75V to 5.5VPackage Thermal Resistance (θ_{JA} (Note 3))8-Pin SOIC 190°C/W **5V Electrical Characteristics** (Note 4)

Unless otherwise specified, all limits are guaranteed for $T_A = 25^\circ\text{C}$, $V_S = 5V$, GND = 0, $-2V \leq V_{CM} \leq 27V$, $R_L = \text{Open}$. **Bold-face** limits apply at the temperature extremes.

Symbol	Parameter	Conditions		Min	Typ (Note 5)	Max	Units
V_{OS}	Input Offset Voltage	$V_{CM} = V_S/2$ (Note 6)			± 0.25	± 1.0	mV
TC V_{OS}	Input Offset Voltage Drift	$V_{CM} = V_S/2$	$25^\circ\text{C} \leq T_A \leq 125^\circ\text{C}$		± 6	± 15	$\mu\text{V}/^\circ\text{C}$
			$-40^\circ\text{C} \leq T_A \leq 25^\circ\text{C}$		± 6	± 20	
A2 I_B	Input Bias Current of A2	(Note 7)				± 20	nA
I_S	Supply Current				1.0	1.2 1.4	mA
R_{CM}	Input Impedance Common Mode			160	200	240	k Ω
R_{DM}	Input Impedance Differential Mode			320	400	480	k Ω
CMVR	Input Common-Mode Voltage Range	Continuous		-2		+27	V
ECMVR	Extended Common-Mode Voltage Range			-2		36	V
DC CMRR	DC Common Mode Rejection Ratio	$0^\circ\text{C} \leq T_A \leq 125^\circ\text{C}$	$-2V \leq V_{CM} \leq 27V$ $-2V \leq V_{CM} \leq 36V$	80 60	97		dB
		$-40^\circ\text{C} \leq T_A \leq 0^\circ\text{C}$	$-2V \leq V_{CM} \leq 27V$ $-2V \leq V_{CM} \leq 36V$	77 60			
AC CMRR	AC Common Mode Rejection Ratio (Note 8)	$-2V \leq V_{CM} \leq 27V$	$f = 1\text{ kHz}$ $f = 10\text{ kHz}$	80	95 78		dB
PSRR	Power Supply Rejection Ratio	$4.75V \leq V_S \leq 5.5V$		70	80		dB
R_{F-INT}	Filter Resistor			97	100	103	k Ω
TCR _{F-INT}	Filter Resistor Drift				20		ppm/ $^\circ\text{C}$
A_V	Total Gain			13.86	14	14.14	V/V
	Gain Drift				± 2	± 25	ppm/ $^\circ\text{C}$
A_{V1}	A1 Gain			6.93	7	7.07	V/V
A_{V2}	A2 Gain			1.98	2	2.02	V/V
A1 V_{OUT}	A1 Output Voltage Swing		VOL		0.004	0.01	V
			VOH	4.80	4.95		
A2 V_{OUT}	A2 Output Voltage Swing (Notes 9, 10)	$R_L = 100\text{ k}\Omega$ on Output	VOL		0.007	0.02	V
			VOH	4.80	4.99		
		$R_L = 10\text{ k}\Omega$ on Output	VOL		0.003		V
			VOH		4.95		
SR	Slew Rate (Note 11)				0.7		V/ μs
BW	Bandwidth				80		kHz

5V Electrical Characteristics (Note 4) (Continued)

Unless otherwise specified, all limits are guaranteed for $T_A = 25^\circ\text{C}$, $V_S = 5\text{V}$, $\text{GND} = 0$, $-2\text{V} \leq V_{\text{CM}} \leq 27\text{V}$, $R_L = \text{Open}$. **Bold-face** limits apply at the temperature extremes.

Symbol	Parameter	Conditions	Min	Typ (Note 5)	Max	Units
Noise	0.1 Hz to 10 Hz			3.82		μV_{PP}
	Spectral Density	$f = 1 \text{ kHz}$		486		$\text{nV}/\sqrt{\text{Hz}}$

Note 1: Absolute Maximum Ratings indicate limits beyond which damage to the device may occur. Operating Ratings indicate conditions for which the device is intended to be functional, but specific performance is not guaranteed. For guaranteed specifications and the test conditions, see the Electrical Characteristics Tables.

Note 2: Human Body Model is $1.5 \text{ k}\Omega$ in series with 100 pF . Machine Model is 0Ω in series with 200 pF .

Note 3: The maximum power dissipation is a function of $T_{\text{J}(\text{MAX})}$, θ_{JA} , and T_A . The maximum allowable power dissipation at any ambient temperature is $P_D = (T_{\text{J}(\text{MAX})} - T_A) / \theta_{\text{JA}}$. All numbers apply for packages soldered directly onto a PC board.

Note 4: Electrical table values apply only for factory testing conditions at the temperature indicated. Factory testing conditions result in very limited self-heating of the device.

Note 5: Typical values represent the parametric norm at the time of characterization.

Note 6: The V_{OS} maximum limit indicated does not include effect of lifetime drift, see Application Note.

Note 7: Positive current corresponds to current flowing into the device.

Note 8: AC Common Mode Signal is a 24 V_{PP} sine-wave (0V to 24V) at the given frequency.

Note 9: For V_{OL} , R_L is connected to V_S and for V_{OH} , R_L is connected to GND .

Note 10: For this test input is driven from A1 stage.

Note 11: Slew rate is the average of the rising and falling slew rates.

Connection Diagram

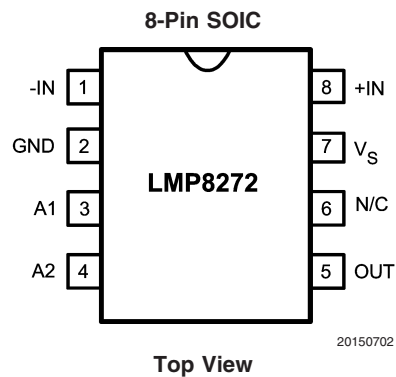

Ordering Information

Package	Part Number	Package Marking	Transport Media	NSC Drawing
SOIC-8	LMP8272MA	LMP8272MA	95 Units/Rail	M08A
	LMP8271MAX		2.5k Units Tape and Reel	

Typical Performance Characteristics Unless otherwise specified: $T_A = 25^\circ\text{C}$, $V_S = 5\text{V}$, $V_{CM} = V_S/2$

V_{OS} vs. V_{CM} Over Temperature

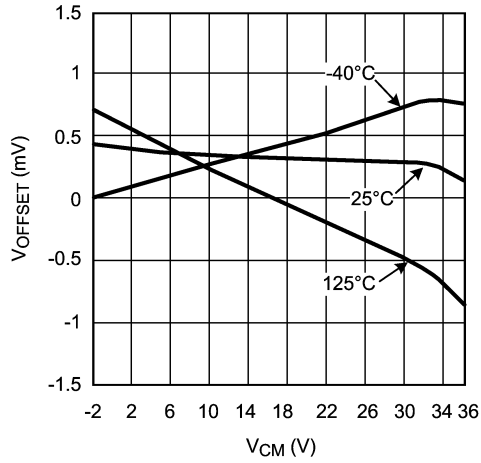

20150715

Typical V_{OS} vs. Temperature

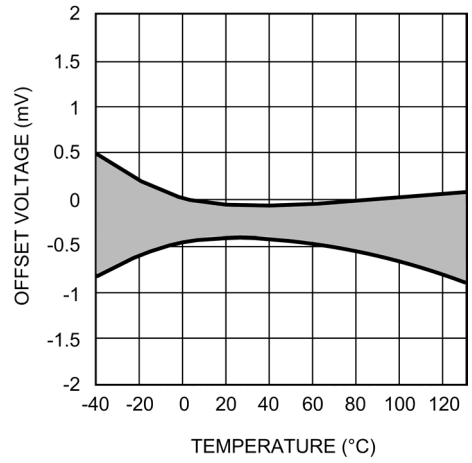

20150721

Input Bias Current Over Temperature (A1 Inputs)

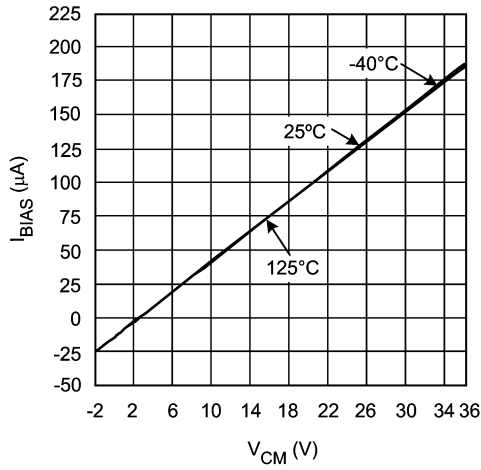

20150719

Input Bias Current Over Temperature (A2 Inputs)

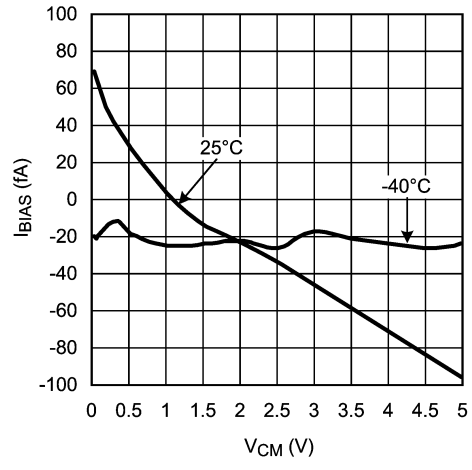

20150718

Input Bias Current Over Temperature (A2 Inputs)

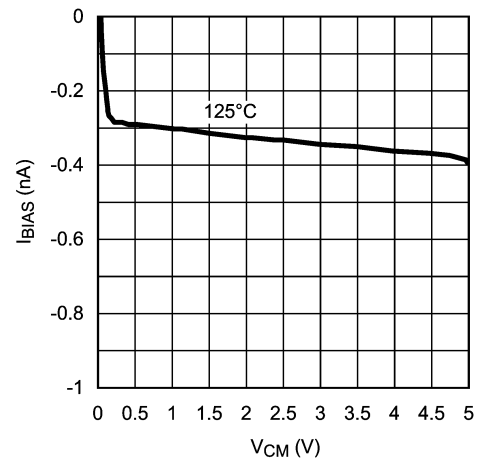

20150720

Input Referred Voltage Noise vs. Frequency

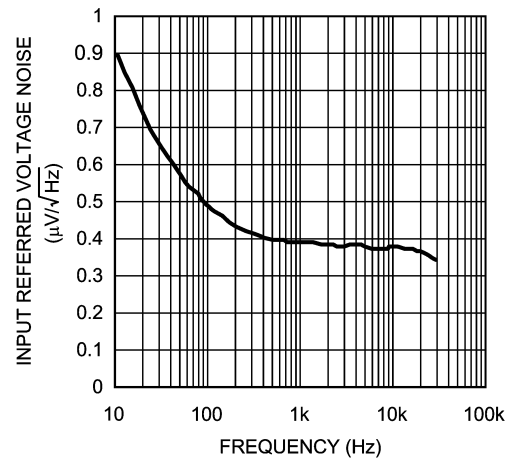

20150706

Typical Performance Characteristics Unless otherwise specified: $T_A = 25^\circ\text{C}$, $V_S = 5\text{V}$, $V_{CM} = V_S/2$
 (Continued)

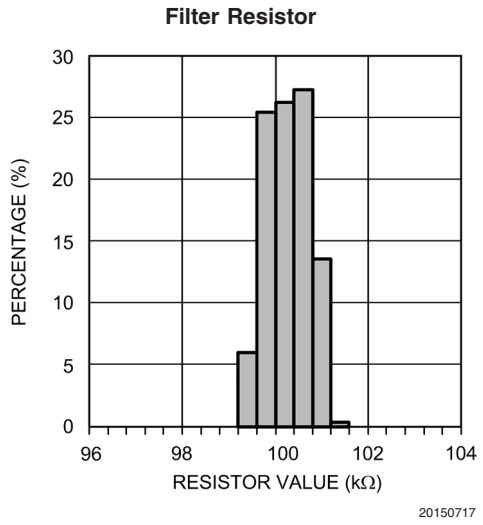
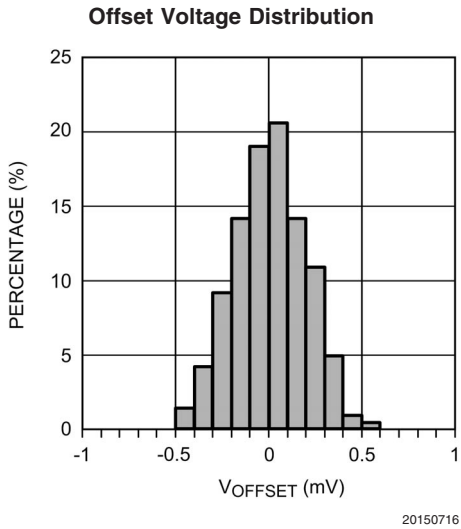
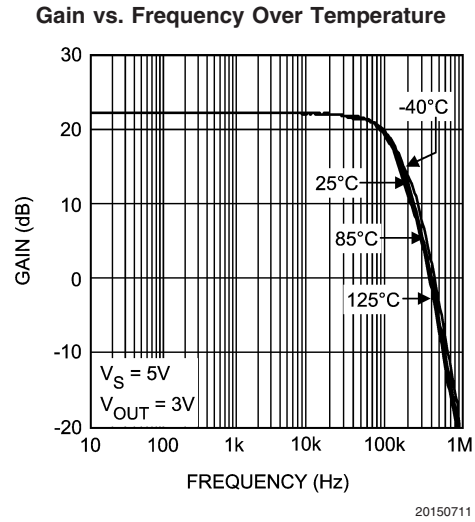
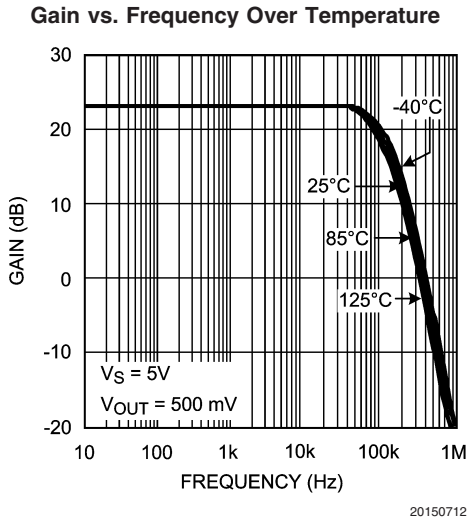
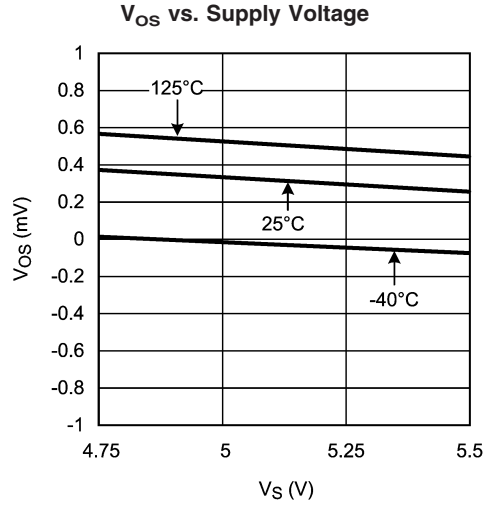
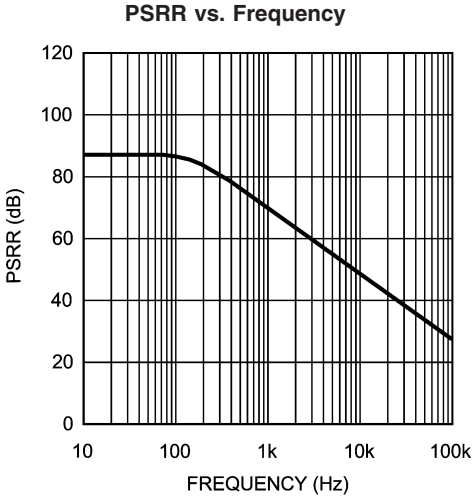

Typical Performance Characteristics

(Continued)

Unless otherwise specified: $T_A = 25^\circ\text{C}$, $V_S = 5\text{V}$, $V_{\text{CM}} = V_S/2$

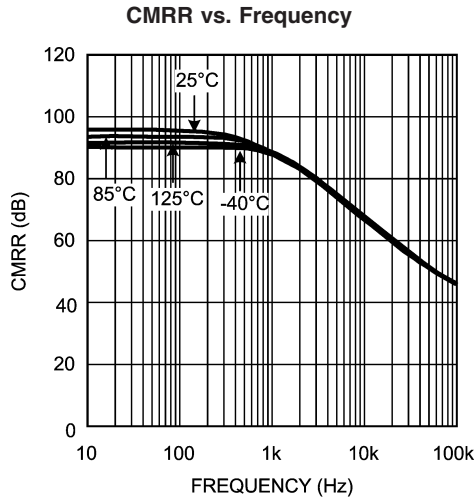

20150714

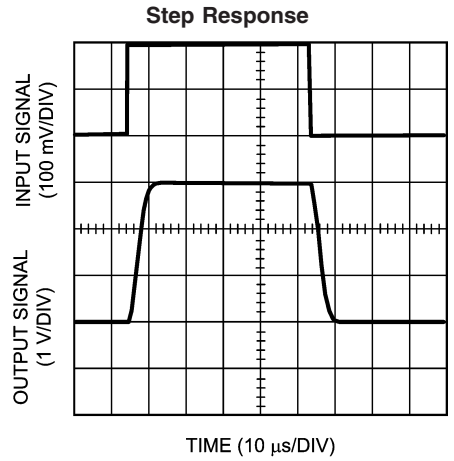

20150708

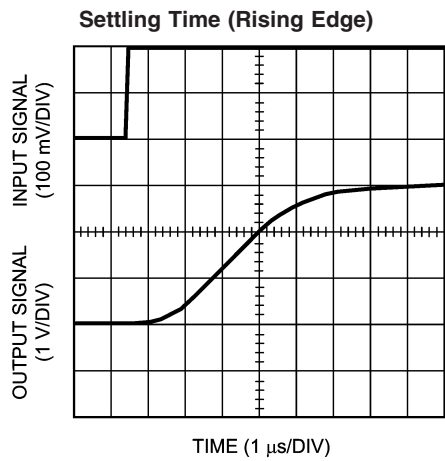

20150710

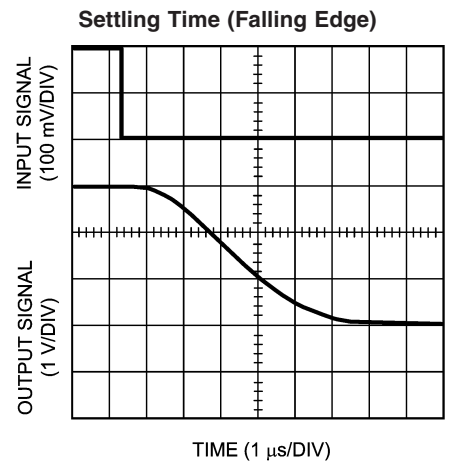

20150709

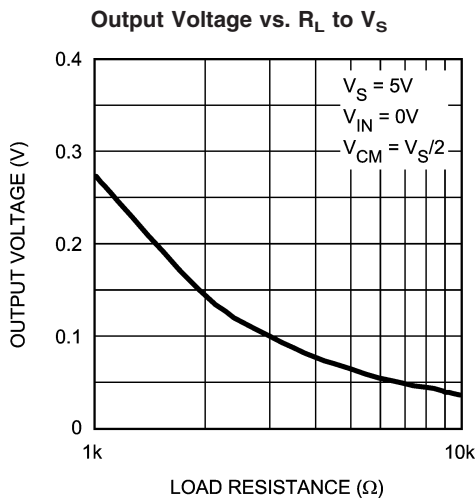

20150713

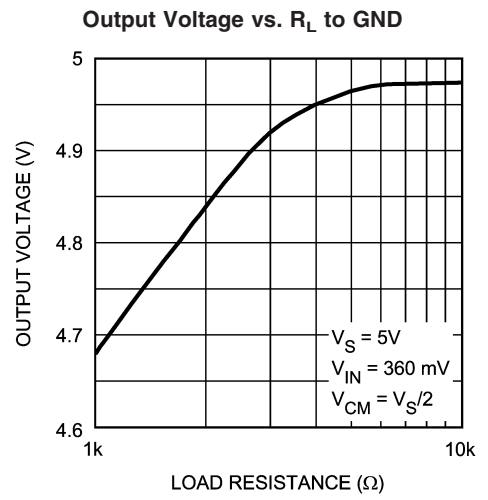

20150707

Application Note

LMP8272

The LMP8272 is a single supply amplifier with a fixed gain of 14 and an extended common mode voltage range of -2V to 36V . The fixed gain is achieved in two separate stages, a preamplifier with gain of $+7$ and a second stage amplifier with gain of $+2$. A block diagram of the LMP8272 is shown in Figure 1.

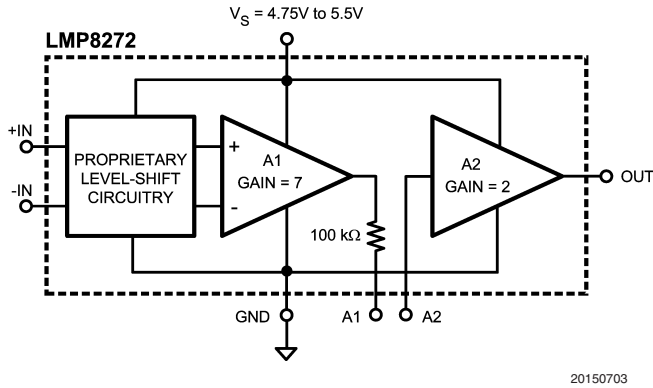

FIGURE 1.

The overall offset of the LMP8272 is minimized by trimming amplifier A1. This is done so that the output referred offset of A1 cancels the input referred offset of A2 or $7V_{OS1} = -V_{OS2}$. Because of this offset voltage relationship, the offset of each individual amplifier stage may be more than the limit specified for the overall system in the datasheet tables. Care must be given when pin 3 and 4, A1 and A2, are connected to each other. If the signal going from A1 to A2 is amplified or attenuated (by use of amplifiers and resistors), the overall LMP8272 offset will be affected as a result. Filtering the signal between A1 and A2 or simply connecting the two pins will not change the offset of the LMP8272.

Referencing the input referred offset voltages of each stage, the following relationship holds:

$$\frac{(7V_{OS1}) + (V_{OS2})}{7} = V_{OS} (\text{LMP8272})$$

If the signal on pin 3 is scaled, attenuated or amplified, by a factor X , then the offset of the overall system will become:

$$\frac{(7V_{OS1}) \times (X) + (V_{OS2})}{7(X)} = V_{OS} (\text{LMP8272})$$

LIFETIME DRIFT

Input Offset Voltage is an electrical parameter which may drift over time. This drift, known as life time drift, is very common in operational amplifiers; however, its effect is more evident in precision amplifiers. This is due to the very low Input Offset Voltage specifications in these amplifiers.

Numerous reliability tests have been performed to characterize this drift for the LMP827X family of products. Prior to each long term reliability test the Input Offset Voltage of LMP827X was measured at room temperature. The LMP827X was then subjected to a preconditioning sequence

consisting of a 16 hour bake at 125°C ; an unbiased 168 hour Temperature Humidity Storage Test, THST, at 85°C and 85% humidity; four passes of infra-red reflow with a maximum temperature of 260°C ; and finally one hundred 30 min Temperature Cycles, TMCL, between -65°C and 150°C (15 min at each temperature).

The long term reliability tests include Operating Life Time, OPL, performed at 150°C for an extended period of time; Temperature Humidity Bias Testing, THBT, at 85°C and 85% humidity for an extended period of time; and repeated cycles of TMCL.

The Offset Voltage was measured again after each reliability test at room temperature. The Offset Voltage Drift is the difference between the initial measurement, before preconditioning, and the later measurement, post preconditioning and reliability test.

Figure 2 below shows the offset voltage drift after preconditioning and 1000 hours of OPL

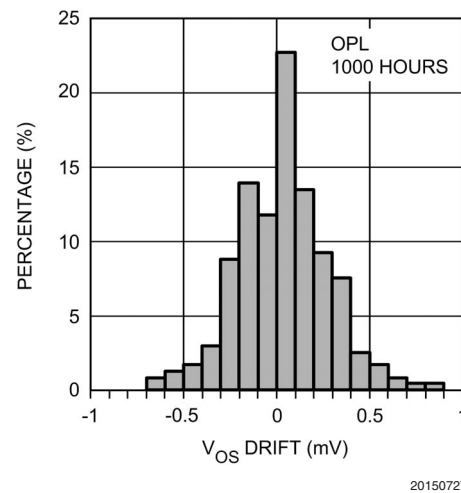

FIGURE 2.

Figure 3 shows the offset voltage drift after preconditioning and 1000 hours of THBT

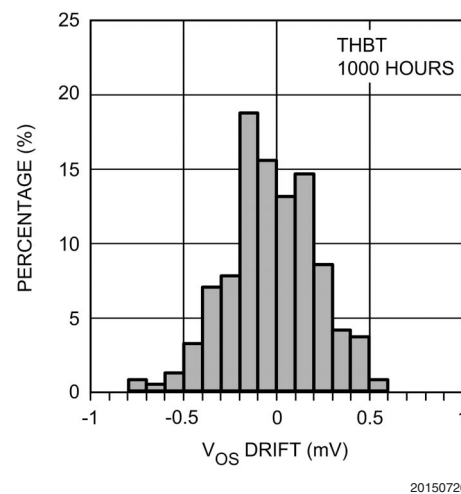
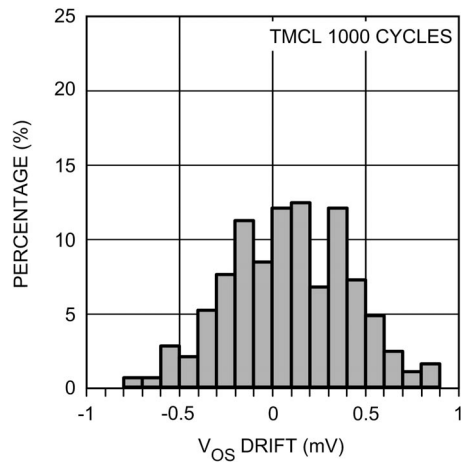

FIGURE 3.

Application Note (Continued)

Figure 4 shows the offset voltage drift after preconditioning and a total of 1000 TMCL cycles



20150725

FIGURE 4.

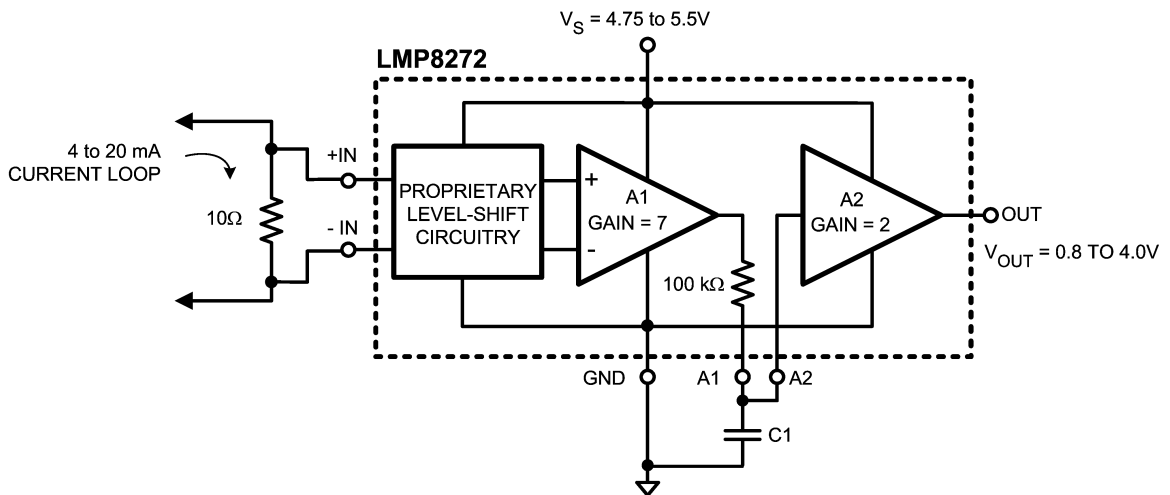

20150728

FIGURE 5.

HIGH SIDE CURRENT SENSING

High side current measurement requires a differential amplifier with gain. Here the DC voltage source represents a common mode voltage with the +IN input at the supply voltage and the -IN input very close to the supply voltage. The LMP8272 can be used with a common mode voltage, V_{DC} in this case, of up to 36V.

The LMP8272 can be used for high side current sensing. The large common mode voltage range of this device allows

POWER SUPPLY DECOUPLING

In order to decouple the LMP8272 from AC noise on the power supply, it is recommended to use a $0.1\ \mu F$ on the supply pin. It is best to use a $0.1\ \mu F$ capacitor in parallel with a $10\ \mu F$ capacitor. This will generate an AC path to ground for most frequency ranges and will greatly reduce the noise introduced by the power supply.

CURRENT LOOP RECEIVER

Many types of process control instrumentation use 4 to 20 mA transmitters to transmit the sensor's analog value to a central control room. The LMP8272 can be used as a current loop receiver as shown in Figure 5.

it to sense signals outside of its supply voltage range. Also, the LMP8272 has very high CMRR, which enables it to sense very small signals in presence of larger common mode signals. The system in Figure 6 couples these two characteristics of the LMP8272 in an automotive application. The signal through R_{S1} is detected and amplified by LMP8272 in the presence of a common mode signal of up to 27V with highest accuracy.

Application Note (Continued)

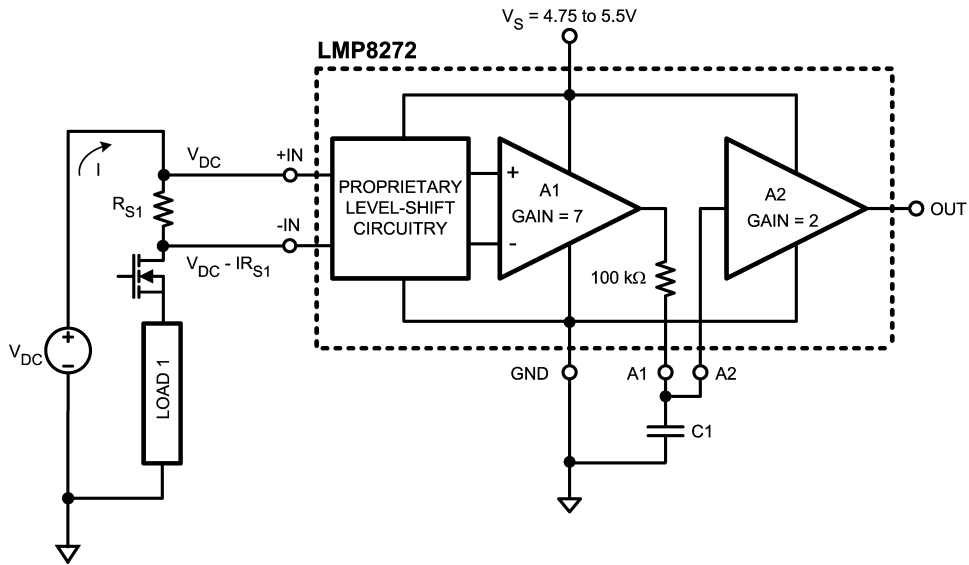

20150729

FIGURE 6.

LOW SIDE CURRENT SENSING

Low side current measurements can cause a problem for operational amplifiers by exceeding the negative common mode voltage limit of the device. In *Figure 7*, the load current is returning to the power source through a common connection that has a parasitic resistance. The voltage drop across the parasitic resistances can cause the ground connection of

the measurement circuits to be at a positive voltage with respect to the common side of the sense resistor. This will result in one or both of the inputs being negative with respect to the circuit's ground. The LMP8272 has a wide extended input common mode voltage range of $-2V$ to $36V$ and will function in this condition.

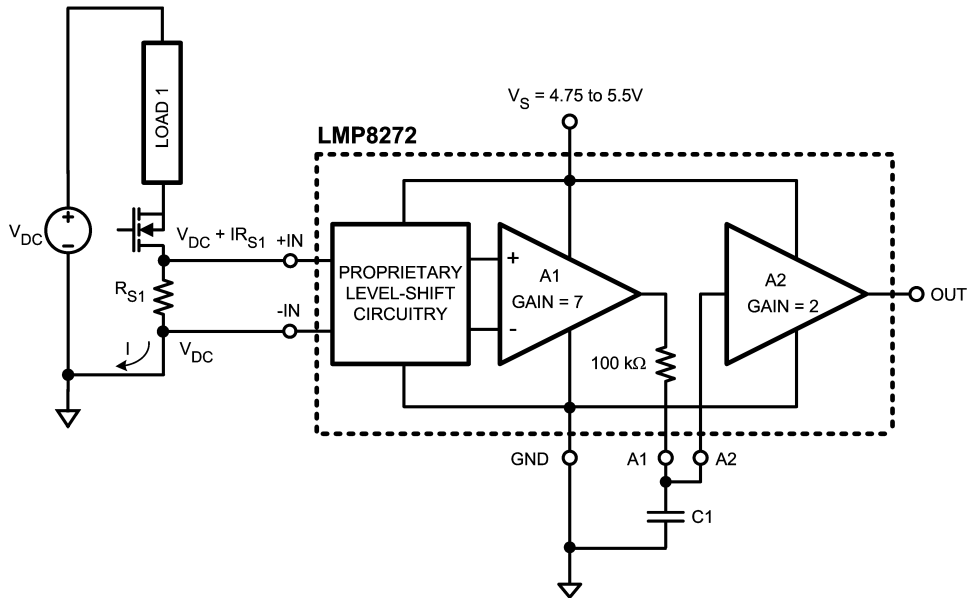

20150730

FIGURE 7.

Application Note (Continued)

SECOND ORDER LOW-PASS FILTER

The LMP8272 can be effectively used to build a second order Sallen-Key low pass filter. The general filter is shown in Figure 8.

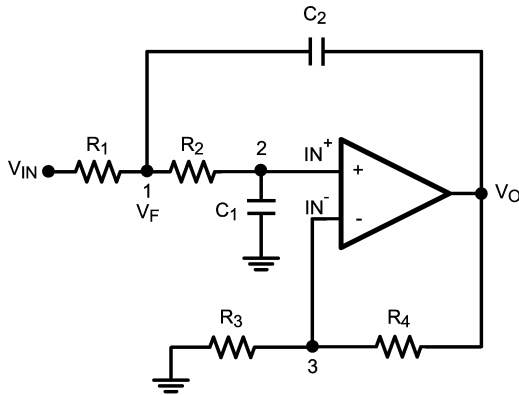

20150731

FIGURE 8.

With the general transfer function:

$$\frac{V_O}{V_{IN}} = \frac{K}{M - KN}$$

(1)

Where:

$$M = s^2 C_1 C_2 R_1 R_2 + s(R_1 C_1 + R_1 C_2 + C_1 R_2) + 1$$

$$N = s C_2 R_1$$

and

$$\frac{1}{K} = \frac{1}{A_{VOL}} + \frac{R_3}{R_3 + R_4}$$

K represents the sum of DC closed loop gain and the non-ideality behavior of the operational amplifier. Assuming ideal behavior, the equation for K reduces simply to DC gain, which is set to +2 for the LMP8272.

The LMP8272 can be used to realize this configuration as shown in Figure 9:

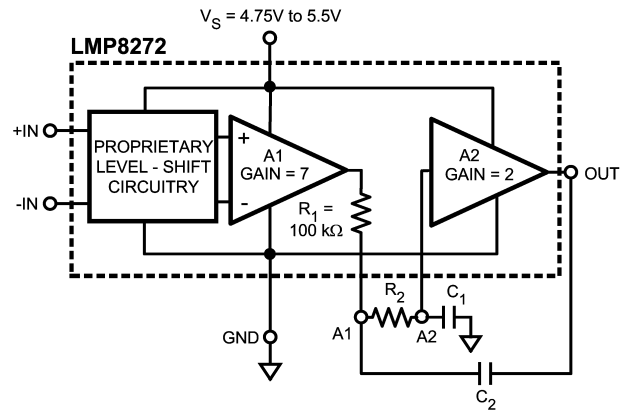

20150753

FIGURE 9.

Using Equation (1), the filter parameters can be calculated as follows:

$$\omega_o = \frac{1}{\sqrt{R_1 R_2 C_1 C_2}}$$

$$f_c = \frac{1}{2\pi \sqrt{R_1 R_2 C_1 C_2}}$$

$$Q = \frac{\sqrt{R_1 R_2 C_1 C_2}}{R_1 C_1 + R_2 C_1 + (1-K) R_1 C_2}$$

for the LMP8270, $R_1 = 100 \text{ k}\Omega$. Setting $R_1 = R_2$ and $C_1 = C_2$ results in a low-pass filter with $Q = 1$. Since values of resistors are predetermined, the corner frequency of this implementation of the filter depends on the capacitor values.

GAINS OTHER THAN 14

The LMP8272 has an internal gain of +14; however, this gain can be modified. The signal path between the two amplifiers is available as external pins.

GAINS LESS THAN 14

Figure 10 shows the configuration used to reduce the LMP8272 gain.

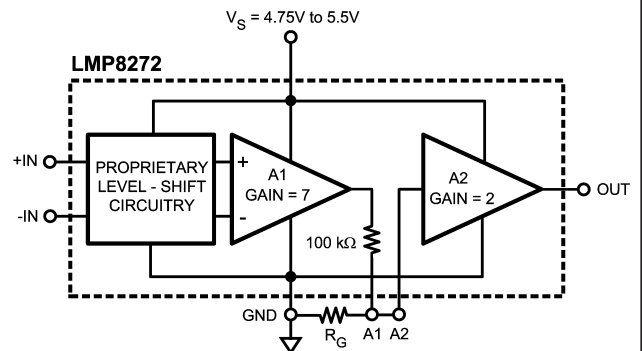

20150747

FIGURE 10.

Application Note (Continued)

Where:

$$\text{GAIN (NEW)} = \frac{14 R_G}{R_G + 100 \text{ k}\Omega}$$

and

$$R_G = (100 \text{ k}\Omega) \frac{\text{GAIN (NEW)}}{14 - \text{GAIN (NEW)}}$$

GAINS GREATER THAN 14

A higher gain can be achieved by using positive feedback on the second stage amplifier, A2, of LMP8272. Figure 11 shows the configuration.

The total gain is given by:

$$\text{GAIN (NEW)} = \frac{14 R_G}{R_G - 100 \text{ k}\Omega}$$

Which can be rearranged to calculate R_G :

$$R_G = (100 \text{ k}\Omega) \frac{\text{GAIN (NEW)}}{\text{GAIN (NEW)} - 14}$$

The inverting gain of the second amplifier is set at 2, giving a total system gain of 14. The non-inverting gain which is achieved through positive feedback can be less than or equal to this gain without any issues. This implies a total system gain of 28 or less is easily achievable. Once the positive gain surpasses the negative gain, the system might oscillate.

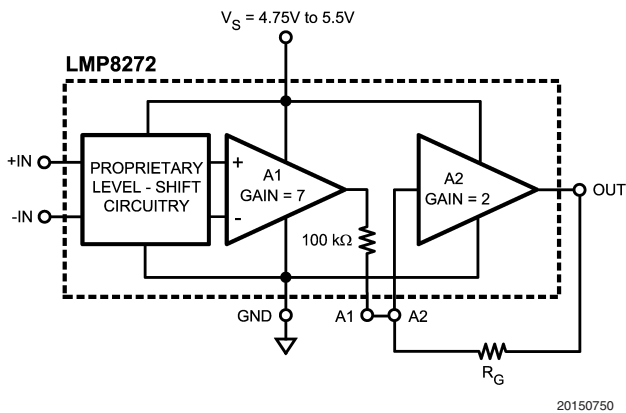
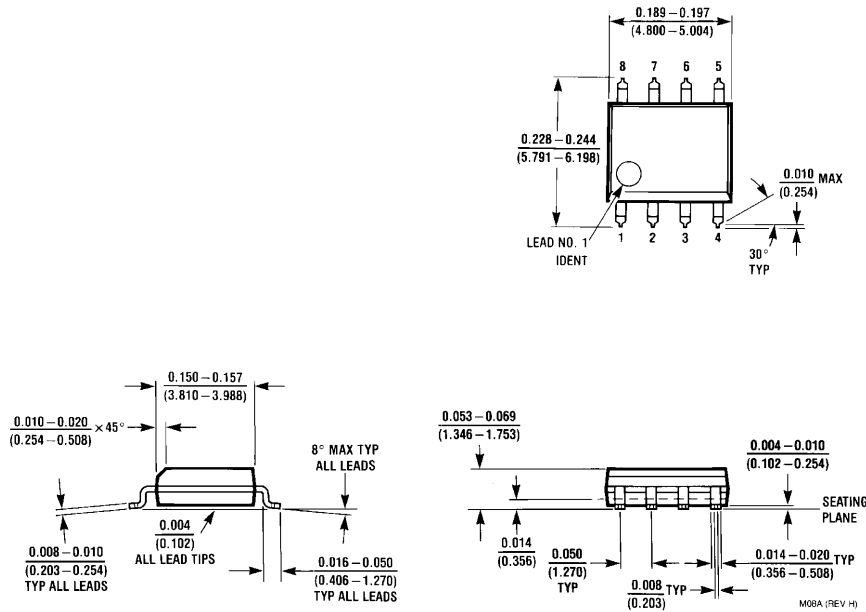

FIGURE 11.

Physical Dimensions inches (millimeters) unless otherwise noted



**8-Pin SOIC
NSC Package Number M08A**

National does not assume any responsibility for use of any circuitry described, no circuit patent licenses are implied and National reserves the right at any time without notice to change said circuitry and specifications.

For the most current product information visit us at www.national.com.

LIFE SUPPORT POLICY

NATIONAL'S PRODUCTS ARE NOT AUTHORIZED FOR USE AS CRITICAL COMPONENTS IN LIFE SUPPORT DEVICES OR SYSTEMS WITHOUT THE EXPRESS WRITTEN APPROVAL OF THE PRESIDENT AND GENERAL COUNSEL OF NATIONAL SEMICONDUCTOR CORPORATION. As used herein:

1. Life support devices or systems are devices or systems which, (a) are intended for surgical implant into the body, or (b) support or sustain life, and whose failure to perform when properly used in accordance with instructions for use provided in the labeling, can be reasonably expected to result in a significant injury to the user.
2. A critical component is any component of a life support device or system whose failure to perform can be reasonably expected to cause the failure of the life support device or system, or to affect its safety or effectiveness.

BANNED SUBSTANCE COMPLIANCE

National Semiconductor manufactures products and uses packing materials that meet the provisions of the Customer Products Stewardship Specification (CSP-9-111C2) and the Banned Substances and Materials of Interest Specification (CSP-9-111S2) and contain no "Banned Substances" as defined in CSP-9-111S2.

Leadfree products are RoHS compliant.



National Semiconductor
Americas Customer
Support Center
Email: new.feedback@nsc.com
Tel: 1-800-272-9959

National Semiconductor
Europe Customer Support Center
Fax: +49 (0) 180-530 85 86
Email: europa.support@nsc.com
Deutsch Tel: +49 (0) 69 9508 6208
English Tel: +44 (0) 870 24 0 2171
Français Tel: +33 (0) 1 41 91 8790

National Semiconductor
Asia Pacific Customer
Support Center
Email: ap.support@nsc.com

National Semiconductor
Japan Customer Support Center
Fax: 81-3-5639-7507
Email: jpn.feedback@nsc.com
Tel: 81-3-5639-7560