

SN54390, SN54LS390, SN54393, SN54LS393 SN74390, SN74LS390, SN74393, SN74LS393 DUAL 4-BIT DECADE AND BINARY COUNTERS

SDLS107 - OCTOBER 1976 - REVISED MARCH 1988

- Dual Versions of the Popular '90A, 'LS90 and '93A, 'LS93
- '390, 'LS390 . . . Individual Clocks for A and B Flip-Flops Provide Dual $\div 2$ and $\div 5$ Counters
- '393, 'LS393 . . . Dual 4-Bit Binary Counter with Individual Clocks
- All Have Direct Clear for Each 4-Bit Counter
- Dual 4-Bit Versions Can Significantly Improve System Densities by Reducing Counter Package Count by 50%
- Typical Maximum Count Frequency . . . 35 MHz
- Buffered Outputs Reduce Possibility of Collector Commutation

description

Each of these monolithic circuits contains eight master-slave flip-flops and additional gating to implement two individual four-bit counters in a single package. The '390 and 'LS390 incorporate dual divide-by-two and divide-by-five counters, which can be used to implement cycle lengths equal to any whole and/or cumulative multiples of 2 and/or 5 up to divide-by-100. When connected as a bi-quinary counter, the separate divide-by-two circuit can be used to provide symmetry (a square wave) at the final output stage. The '393 and 'LS393 each comprise two independent four-bit binary counters each having a clear and a clock input. N-bit binary counters can be implemented with each package providing the capability of divide-by-256. The '390, 'LS390, '393, and 'LS393 have parallel outputs from each counter stage so that any submultiple of the input count frequency is available for system-timing signals.

Series 54 and Series 54LS circuits are characterized for operation over the full military temperature range of -55°C to 125°C ; Series 74 and Series 74LS circuits are characterized for operation from 0°C to 70°C .

SN54390, SN54LS390 . . . J OR W PACKAGE
SN74390 . . . N PACKAGE
SN74LS390 . . . D OR N PACKAGE

(TOP VIEW)

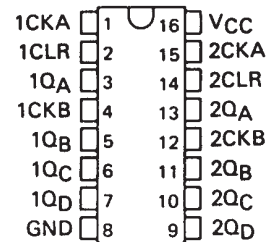

SN54LS390 . . . FK PACKAGE

(TOP VIEW)

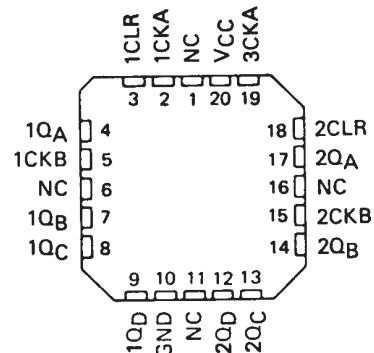

SN54393, SN54LS393 . . . J OR W PACKAGE
SN74393 . . . N PACKAGE
SN74LS393 . . . D OR N PACKAGE

(TOP VIEW)

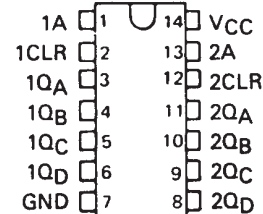

SN54LS393 . . . FK PACKAGE

(TOP VIEW)

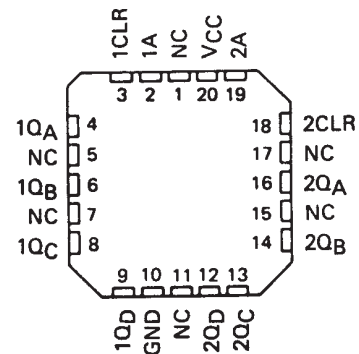

NC - No internal connection

SN54390, SN54LS390, SN54393, SN54LS393 SN74390, SN74LS390, SN74393, SN74LS393 DUAL 4-BIT DECADE AND BINARY COUNTERS

SDLS107 - OCTOBER 1976 - REVISED MARCH 1988

**'390, 'LS390
BCD COUNT SEQUENCE
(EACH COUNTER)
(See Note A)**

COUNT	OUTPUT			
	Q _D	Q _C	Q _B	Q _A
0	L	L	L	L
1	L	L	L	H
2	L	L	H	L
3	L	L	H	H
4	L	H	L	L
5	L	H	L	H
6	L	H	H	L
7	L	H	H	H
8	H	L	L	L
9	H	L	L	H

**FUNCTION TABLES
'390, 'LS390
BI-QUINARY (5-2)
(EACH COUNTER)
(See Note B)**

COUNT	OUTPUT			
	Q _A	Q _D	Q _C	Q _B
0	L	L	L	L
1	L	L	L	H
2	L	L	H	L
3	L	L	H	H
4	L	H	L	L
5	H	L	L	L
6	H	L	L	H
7	H	L	H	L
8	H	L	H	H
9	H	H	L	L

**'393, 'LS393
COUNT SEQUENCE
(EACH COUNTER)**

COUNT	OUTPUT			
	Q _D	Q _C	Q _B	Q _A
0	L	L	L	L
1	L	L	L	H
2	L	L	H	L
3	L	L	H	H
4	L	H	L	L
5	L	H	L	H
6	L	H	H	L
7	L	H	H	H
8	H	L	L	L
9	H	L	L	H
10	H	L	H	L
11	H	L	H	H
12	H	H	L	L
13	H	H	L	H
14	H	H	H	L
15	H	H	H	H

NOTES: A. Output Q_A is connected to input B for BCD count.
B. Output Q_D is connected to input A for bi-quinary count.
C. H = high level, L = low level.

logic diagrams (positive logic)

'390, 'LS390



logic symbols †

'390, 'LS390



'393, 'LS393



†These symbols are in accordance with ANSI/IEEE Std. 91-1984 and IEC Publication 617-12.

Pin numbers shown are for D, J, N, and W packages.



POST OFFICE BOX 655303 • DALLAS, TEXAS 75265

SN54390, SN54LS390, SN54393, SN54LS393 SN74390, SN74LS390, SN74393, SN74LS393 DUAL 4-BIT DECADE AND BINARY COUNTERS

SDLS107 – OCTOBER 1976 – REVISED MARCH 1988

absolute maximum ratings over operating free-air temperature range (unless otherwise noted)

Supply voltage, V_{CC} (see Note 1)	7 V
Input voltage	5.5 V
Operating free-air temperature range: SN54390, SN54393	-55°C to 125°C
SN74390, SN74393	0°C to 70°C
Storage temperature range	-65°C to 150°C

NOTE 1: Voltage values are with respect to network ground terminal.

recommended operating conditions

	SN54390 SN54393			SN74390 SN74393			UNIT	
	MIN	NOM	MAX	MIN	NOM	MAX		
Supply voltage, V_{CC}	4.5	5	5.5	4.75	5	5.25	V	
High-level output current, I_{OH}			-800			-800	μ A	
Low-level output current, I_{OL}			16			16	mA	
Count frequency, f_{count}	A input		0	25	0		25	MHz
	B input		0	20	0		20	
Pulse width, t_w	A input high or low		20		20		ns	
	B input high or low		25		25			
	Clear high		20		20			
Clear inactive-state setup time, t_{SU}	25↓		25↓				ns	
Operating free-air temperature, T_A	-55		125		0		70	°C

↓ The arrow indicates that the falling edge of the clock pulse is used for reference.

electrical characteristics over recommended operating free-air temperature range (unless otherwise noted)

PARAMETER	TEST CONDITIONS†	'390			'393			UNIT
		MIN	TYP‡	MAX	MIN	TYP‡	MAX	
V_{IH} High-level input voltage		2			2			V
V_{IL} Low-level input voltage		0.8			0.8			V
V_{IK} Input clamp voltage	$V_{CC} = \text{MIN}, I_I = -12 \text{ mA}$	-1.5			-1.5			V
V_{OH} High-level output voltage	$V_{CC} = \text{MIN}, V_{IH} = 2 \text{ V}, V_{IL} = 0.8 \text{ V}, I_{OH} = -800 \mu\text{A}$	2.4	3.4		2.4	3.4		V
V_{OL} Low-level output voltage	$V_{CC} = \text{MIN}, V_{IH} = 2 \text{ V}, V_{IL} = 0.8 \text{ V}, I_{OL} = 16 \text{ mA} \uparrow$		0.2	0.4		0.2	0.4	V
I_I Input current at maximum input voltage	$V_{CC} = \text{MAX}, V_I = 5.5 \text{ V}$	1			1			mA
I_{IH} High-level input current	Clear	40			40			μ A
	Input A	80			80			
	Input B	120						
I_{IL} Low-level input current	Clear	-1			-1			mA
	Input A	-3.2			-3.2			
	Input B	-4.8						
I_{OS} Short-circuit output current §	$V_{CC} = \text{MAX}$	SN54'	-20	-57	-20	-57	mA	
		SN74'	-18	-57	-18	-57		
I_{CC} Supply current	$V_{CC} = \text{MAX}, \text{ See Note 2}$	42	69		38	64	mA	

† For conditions shown as MIN or MAX, use the appropriate value specified under recommended operating conditions.

‡ All typical values are at $V_{CC} = 5 \text{ V}, T_A = 25^\circ\text{C}$.

§ Not more than one output should be shorted at a time.

¶ The Q_A outputs of the '390 are tested at $I_{OL} = 16 \text{ mA}$ plus the limit value for I_{IL} for the B input. This permits driving the B input while maintaining full fan-out capability.

NOTE 2: I_{CC} is measured with all outputs open, both clear inputs grounded following momentary connection to 4.5 V, and all other inputs grounded.



SN54390, SN54LS390, SN54393, SN54LS393
 SN74390, SN74LS390, SN74393, SN74LS393
 DUAL 4-BIT DECADE AND BINARY COUNTERS

SDLS107 – OCTOBER 1976 – REVISED MARCH 1988

switching characteristics, $V_{CC} = 5\text{ V}$, $T_A = 25^\circ\text{C}$

PARAMETER	FROM (INPUT)	TO (OUTPUT)	TEST CONDITIONS	'390			'393			UNIT
				MIN	TYP	MAX	MIN	TYP	MAX	
f_{\max}	A	Q_A	$C_L = 15\text{ pF}$, $R_L = 400\ \Omega$, See Note 3 and Figure 1	25	35		25	35	MHz	
	B	Q_B		20	30					
t_{PLH}	A	Q_A		12	20		12	20	ns	
t_{PHL}				13	20		13	20		
t_{PLH}	A	Q_C of '390 Q_D of '393		37	60		40	60	ns	
t_{PHL}				39	60		40	60		
t_{PLH}	B	Q_B		13	21				ns	
t_{PHL}				14	21					
t_{PLH}	B	Q_C		24	39				ns	
t_{PHL}				26	39					
t_{PLH}	B	Q_D		13	21				ns	
t_{PHL}				14	21					
t_{PHL}	Clear	Any		24	39		24	39	ns	

NOTE 3: Load circuits and voltage waveforms are shown in Section 1.

SN54390, SN54LS390, SN54393, SN54LS393
 SN74390, SN74LS390, SN74393, SN74LS393
 DUAL 4-BIT DECADE AND BINARY COUNTERS

SDLS107 - OCTOBER 1976 - REVISED MARCH 1988

PARAMETER MEASUREMENT INFORMATION



NOTE A: Input pulses are supplied by a generator having the following characteristics $t_r \leq 5 \text{ ns}$, $t_f \leq 5 \text{ ns}$, PRR = 1 MHz, duty cycle = 50%, $Z_{out} \approx 50 \text{ ohms}$.

FIGURE 1



POST OFFICE BOX 655303 • DALLAS, TEXAS 75265

SN54390, SN54LS390, SN54393, SN54LS393 SN74390, SN74LS390, SN74393, SN74LS393 DUAL 4-BIT DECADE AND BINARY COUNTERS

SDLS107 – OCTOBER 1976 – REVISED MARCH 1988

absolute maximum ratings over operating free-air temperature range (unless otherwise noted)

Supply voltage, V_{CC} (see Note 1)	7 V
Clear input voltage	7 V
Any A or B clock input voltage	5.5 V
Operating free-air temperature range: SN54LS390, SN54LS393	-55°C to 125°C
SN74LS390, SN74LS393	0°C to 70°C
Storage temperature range	-65°C to 150°C

NOTE 1: Voltage values are with respect to network ground terminal.

recommended operating conditions

	SN54LS390 SN54LS393			SN74LS390 SN74LS393			UNIT	
	MIN	NOM	MAX	MIN	NOM	MAX		
Supply voltage, V_{CC}	4.5	5	5.5	4.75	5	5.25	V	
High-level output current, I_{OH}			-400			-400	μ A	
Low-level output current, I_{OL}			4			8	mA	
Count frequency, f_{count}	A input		0	25	0		25	MHz
	B input		0	12.5	0		12.5	
Pulse width, t_w	A input high or low		20		20		ns	
	B input high or low		40		40			
	Clear high		20		20			
Clear inactive-state setup time, t_{SU}	25 \downarrow		25 \downarrow				ns	
Operating free-air temperature, T_A	-55		125		0		70	°C

\downarrow The arrow indicates that the falling edge of the clock pulse is used for reference.

electrical characteristics over recommended operating free-air temperature range (unless otherwise noted)

PARAMETER	TEST CONDITIONS [†]	SN54LS'			SN74LS'			UNIT
		MIN	TYP [‡]	MAX	MIN	TYP [‡]	MAX	
V_{IH} High-level input voltage		2			2			V
V_{IL} Low-level input voltage		0.7			0.8			V
V_{IK} Input clamp voltage	$V_{CC} = \text{MIN}, I_I = -18 \text{ mA}$	-1.5			-1.5			V
V_{OH} High-level output voltage	$V_{CC} = \text{MIN}, V_{IH} = 2 \text{ V}, V_{IL} = V_{IL \text{ max}}, I_{OH} = -400 \mu\text{A}$	2.5	3.4		2.7	3.4		V
V_{OL} Low-level output voltage	$V_{CC} = \text{MIN}, V_{IH} = 2 \text{ V}, V_{IL} = 0.8 \text{ V},$	$I_{OL} = 4 \text{ mA}$ [¶]		0.25	0.4	0.25	0.4	V
		$I_{OL} = 8 \text{ mA}$ [¶]				0.35	0.5	
I_I Input current at maximum input voltage	Clear	$V_{CC} = \text{MAX}$		$V_I = 7 \text{ V}$		0.1	0.1	mA
	Input A			$V_I = 5.5 \text{ V}$		0.2	0.2	
	Input B					0.4	0.4	
I_{IH} High-level input current	Clear	$V_{CC} = \text{MAX}, V_I = 2.7 \text{ V}$				0.02	0.02	mA
	Input A					0.1	0.1	
	Input B					0.2	0.2	
I_{IL} Low-level input current	Clear	$V_{CC} = \text{MAX}, V_I = 0.4 \text{ V}$				-0.4	-0.4	mA
	Input A					-1.6	-1.6	
	Input B					-2.4	-2.4	
I_{OS} Short-circuit output current [§]	$V_{CC} = \text{MAX}$	-20	-100	-20	-100			mA
I_{CC} Supply current	$V_{CC} = \text{MAX},$ See Note 2	'LS390		15	26	15	26	mA
		'LS393		15	26	15	26	

[†] For conditions shown as MIN or MAX, use the appropriate value specified under recommended operating conditions.

[‡] All typical values are at $V_{CC} = 5 \text{ V}, T_A = 25^\circ\text{C}$.

[§] Not more than one output should be shorted at a time, and duration of the short-circuit should not exceed one second.

[¶] The Q_A outputs of the 'LS390 are tested at $I_{OL} = \text{MAX}$ plus the limit value for I_{IL} for the clock B input. This permits driving the clock B input while maintaining full fan-out capability.

NOTE 2: I_{CC} is measured with all outputs open, both clear inputs grounded following momentary connection to 4.5 V, and all other inputs grounded.



**SN54390, SN54LS390, SN54393, SN54LS393
 SN74390, SN74LS390, SN74393, SN74LS393
 DUAL 4-BIT DECADE AND BINARY COUNTERS**

SDLS107 – OCTOBER 1976 – REVISED MARCH 1988

switching characteristics, $V_{CC} = 5\text{ V}$, $T_A = 25^\circ\text{C}$

PARAMETER	FROM (INPUT)	TO (OUTPUT)	TEST CONDITIONS	'LS390			'LS393			UNIT
				MIN	TYP	MAX	MIN	TYP	MAX	
f_{max}	A	Q_A	$C_L = 15\text{ pF}$, $R_L = 2\text{ k}\Omega$, See Note 4 and Figure 2	25	35		25	35	MHz	
	B	Q_B		12.5	20					
t_{PLH}	A	Q_A		12	20		12	20	ns	
t_{PHL}				13	20		13	20		
t_{PLH}	A	Q_C of 'LS390 Q_D of 'LS393		37	60		40	60	ns	
t_{PHL}				39	60		40	60		
t_{PLH}	B	Q_B		13	21				ns	
t_{PHL}				14	21					
t_{PLH}	B	Q_C		24	39				ns	
t_{PHL}				26	39					
t_{PLH}	B	Q_D		13	21				ns	
t_{PHL}				14	21					
t_{PHL}	Clear	Any		24	39		24	39	ns	

NOTE 4: Load circuits and voltage waveforms are shown in Section 1.



PARAMETER MEASUREMENT INFORMATION



VOLTAGE WAVEFORMS

NOTE A: Input pulses are supplied by a generator having the following characteristics $t_r \leq 15$ ns, $t_f \leq 6$ ns, PRR = 1 MHz, duty cycle = 50 %, $Z_{out} \approx 50$ ohms.

FIGURE 2

IMPORTANT NOTICE

Texas Instruments and its subsidiaries (TI) reserve the right to make changes to their products or to discontinue any product or service without notice, and advise customers to obtain the latest version of relevant information to verify, before placing orders, that information being relied on is current and complete. All products are sold subject to the terms and conditions of sale supplied at the time of order acknowledgement, including those pertaining to warranty, patent infringement, and limitation of liability.

TI warrants performance of its semiconductor products to the specifications applicable at the time of sale in accordance with TI's standard warranty. Testing and other quality control techniques are utilized to the extent TI deems necessary to support this warranty. Specific testing of all parameters of each device is not necessarily performed, except those mandated by government requirements.

CERTAIN APPLICATIONS USING SEMICONDUCTOR PRODUCTS MAY INVOLVE POTENTIAL RISKS OF DEATH, PERSONAL INJURY, OR SEVERE PROPERTY OR ENVIRONMENTAL DAMAGE ("CRITICAL APPLICATIONS"). TI SEMICONDUCTOR PRODUCTS ARE NOT DESIGNED, AUTHORIZED, OR WARRANTED TO BE SUITABLE FOR USE IN LIFE-SUPPORT DEVICES OR SYSTEMS OR OTHER CRITICAL APPLICATIONS. INCLUSION OF TI PRODUCTS IN SUCH APPLICATIONS IS UNDERSTOOD TO BE FULLY AT THE CUSTOMER'S RISK.

In order to minimize risks associated with the customer's applications, adequate design and operating safeguards must be provided by the customer to minimize inherent or procedural hazards.

TI assumes no liability for applications assistance or customer product design. TI does not warrant or represent that any license, either express or implied, is granted under any patent right, copyright, mask work right, or other intellectual property right of TI covering or relating to any combination, machine, or process in which such semiconductor products or services might be or are used. TI's publication of information regarding any third party's products or services does not constitute TI's approval, warranty or endorsement thereof.

REAL WORLD SIGNAL PROCESSING™

Search TI

[PRODUCTS](#) ▶ [APPLICATIONS](#) ▶ [SUPPORT](#) ▶ [TI&ME](#) ▶

 • [Advanced Search](#)

PRODUCT FOLDER | PRODUCT INFO: [FEATURES](#) | [DESCRIPTION](#) | [DATASHEETS](#) | [PRICING/AVAILABILITY/PKG](#) | [APPLICATION NOTES](#) | [RELATED DOCUMENTS](#)

 PRODUCT SUPPORT: [TRAINING](#)

SN74LS390, Dual 4-Bit Decade Counters

 DEVICE STATUS: **ACTIVE**

PARAMETER NAME	SN54LS390	SN74LS390
Voltage Nodes (V)	5	5

FEATURES

[▲Back to Top](#)

- Dual Versions of the Popular '90A, 'LS90 and '93A, 'LS93
- '390, 'LS390 ... Individual Clocks for A and B Flip-Flops Provide Dual ÷ 2 and ÷ 5 Counters
- '393, 'LS393 ... Dual 4-Bit Binary Counter with Individual Clocks
- All Have Direct Clear for Each 4-Bit Counter
- Dual 4-Bit Versions Can Significantly Improve System Densities by Reducing Counter Package Count by 50%
- Typical Maximum Count Frequency ... 35 MHz
- Buffered Outputs Reduce Possibility of Collector Commutation

DESCRIPTION

[▲Back to Top](#)

Each of these monolithic circuits contains eight master-slave flip-flops and additional gating to implement two individual four-bit counters in a single package. The '390 and 'LS390 incorporate dual divide-by-two and divide-by-five counters, which can be used to implement cycle lengths equal to any whole and/or cumulative multiples of 2 and/or 5 up to divide-by-100. When connected as a binary counter, the separate divide-by-two circuit can be used to provide symmetry (a square wave) at the final output stage. The '393 and 'LS393 each comprise two independent four-bit binary counters each having a clear and a clock input. N-bit binary counters can be implemented with each package providing the capability of divide-by-256. The '390, 'LS390, '393, and 'LS393 have parallel outputs from each counter stage so that any submultiple of the input count frequency is available for system-timing signals. Series 54 and Series 54LS circuits are characterized for operation over the full military temperature range of -55°C to 125°C; Series 74 and Series 74LS circuits are characterized for operation from 0°C to 70°C.

TECHNICAL DOCUMENTS

[▲Back to Top](#)

To view the following documents, [Acrobat Reader 4.0](#) is required.

To download a document to your hard drive, right-click on the link and choose 'Save'.

DATASHEET

[▲Back to Top](#)

Full datasheet in Acrobat PDF: [sn74ls390.pdf](#) (343 KB) (Updated: 03/01/1988)

APPLICATION NOTES

[▲Back to Top](#)

View Application Notes for [Digital Logic](#)

- [Designing With Logic \(Rev. C\)](#) (SDYA009C - Updated: 06/01/1997)
- [Designing with the SN54/74LS123 \(Rev. A\)](#) (SDLA006A - Updated: 03/01/1997)
- [Evaluation of Nickel/Palladium/Gold-Finished Surface-Mount Integrated Circuits](#) (SZZA026 - Updated: 06/20/2001)
- [Input and Output Characteristics of Digital Integrated Circuits](#) (SDYA010 - Updated: 10/01/1996)
- [Live Insertion](#) (SDYA012 - Updated: 10/01/1996)

RELATED DOCUMENTS

[▲Back to Top](#)

View Related Documentation for [Digital Logic](#)

- [Logic Reference Guide](#) (SCYB004, 1032 KB - Updated: 10/23/2001)
- [Logic Selection Guide Second Half 2002 \(Rev. R\)](#) (SDYU001R, 4274 KB - Updated: 07/19/2002)
- [Military Semiconductors Selection Guide 2002 \(Rev. B\)](#) (SGYC003B, 1648 KB - Updated: 04/22/2002)

PRICING/AVAILABILITY/PKG

[▲Back to Top](#)

DEVICE INFORMATION							TI INVENTORY STATUS AS OF 3:00 PM GMT, 26 Sep 2002			REPORTED DISTRIBUTOR INVENTORY AS OF 3:00 PM GMT, 26 Sep 2002		
ORDERABLE DEVICE	STATUS	PACKAGE TYPE PINS	TEMP (°C)	PRODUCT CONTENT	BUDGETARY PRICING QTY SUS	STD PACK QTY	IN STOCK	IN PROGRESS QTY DATE	LEAD TIME	DISTRIBUTOR COMPANY REGION	IN STOCK	PURCHASE
SN74LS390D	ACTIVE	SOP (D) 16	0 TO 70	View Contents	1KU 0.46	40	1000	> 10k 10 Oct	4 WKS	Avnet AMERICA	650	BUY NOW
SN74LS390DR	ACTIVE	SOP (D) 16	0 TO 70	View Contents	1KU 0.49	2500	N/A*	> 10k 10 Oct	4 WKS			
SN74LS390N	ACTIVE	PDIP (N) 16	0 TO 70	View Contents	1KU 0.41	25	N/A*	119 24 Sep	4 WKS	Avnet AMERICA	> 1k	BUY NOW
								> 10k 04 Oct				
								> 10k 09 Oct				
SN74LS390N3	OBSOLETE	PDIP (N) 16	0 TO 70	View Contents	1KU		N/A*		Not Available			
SN74LS390NSR	ACTIVE	SOP (NS) 16		View Contents	1KU 0.41	2000	N/A*	2000 03 Oct	4 WKS			
								> 10k 04 Oct				
								2302 11 Oct				
								> 10k 18 Oct				

Table Data Updated on: 9/26/2002

[Products](#) | [Applications](#) | [Support](#) | [TI&ME](#)

 **TEXAS INSTRUMENTS** © Copyright 1995-2002 Texas Instruments Incorporated. All rights reserved.
[Trademarks](#) | [Privacy Policy](#) | [Terms of Use](#)

PRODUCT FOLDER | PRODUCT INFO: [FEATURES](#) | [DESCRIPTION](#) | [DATASHEETS](#) | [PRICING/AVAILABILITY/PKG](#) | [APPLICATION NOTES](#) | [RELATED DOCUMENTS](#)

PRODUCT SUPPORT: [TRAINING](#)

SN74LS393, Dual 4-Bit Binary Counters

DEVICE STATUS: **ACTIVE**

PARAMETER NAME	SN54LS393	SN74LS393
Voltage Nodes (V)	5	5
Vcc range (V)	4.5 to 5.5	4.75 to 5.25
Input Level	TTL	TTL
Output Level	TTL	TTL
Output Drive (mA)		-0.4/8
Output	2S	2S
Clear	Async	Async

FEATURES

[▲Back to Top](#)

- Dual Versions of the Popular '90A, 'LS90 and '93A, 'LS93
- '390, 'LS390 ... Individual Clocks for A and B Flip-Flops Provide Dual ÷ 2 and ÷ 5 Counters
- '393, 'LS393 ... Dual 4-Bit Binary Counter with Individual Clocks
- All Have Direct Clear for Each 4-Bit Counter
- Dual 4-Bit Versions Can Significantly Improve System Densities by Reducing Counter Package Count by 50%
- Typical Maximum Count Frequency ... 35 MHz
- Buffered Outputs Reduce Possibility of Collector Commutation

DESCRIPTION

[▲Back to Top](#)

Each of these monolithic circuits contains eight master-slave flip-flops and additional gating to implement two individual four-bit counters in a single package. The '390 and 'LS390 incorporate dual divide-by-two and divide-by-five counters, which can be used to implement cycle lengths equal to any whole and/or cumulative multiples of 2 and/or 5 up to divide-by-100. When connected as a binary counter, the separate divide-by-two circuit can be used to provide symmetry (a square wave) at the final output stage. The '393 and 'LS393 each comprise two independent four-bit binary counters each having a clear and a clock input. N-bit binary counters can be implemented with each package providing the capability of divide-by-256. The '390, 'LS390, '393, and 'LS393 have parallel outputs from each counter stage so that any submultiple of the input count frequency is available for system-timing signals. Series 54 and Series 74LS circuits are characterized for operation over the full military temperature range of -55°C to 125°C; Series 74 and Series 74LS circuits are characterized for operation from 0°C to 70°C.

TECHNICAL DOCUMENTS

[▲Back to Top](#)

To view the following documents, [Acrobat Reader 4.0](#) is required.

To download a document to your hard drive, right-click on the link and choose 'Save'.

DATASHEET

[▲Back to Top](#)

Full datasheet in Acrobat PDF: [sn74ls393.pdf](#) (343 KB) (Updated: 03/01/1988)

View Application Notes for [Digital Logic](#)

- [Designing With Logic \(Rev. C\)](#) (SDYA009C - Updated: 06/01/1997)
- [Designing with the SN54/74LS123 \(Rev. A\)](#) (SDLA006A - Updated: 03/01/1997)
- [Evaluation of Nickel/Palladium/Gold-Finished Surface-Mount Integrated Circuits](#) (SZZA026 - Updated: 06/20/2001)
- [Input and Output Characteristics of Digital Integrated Circuits](#) (SDYA010 - Updated: 10/01/1996)
- [Live Insertion](#) (SDYA012 - Updated: 10/01/1996)

RELATED DOCUMENTSView Related Documentation for [Digital Logic](#)

- [Logic Reference Guide](#) (SCYB004, 1032 KB - Updated: 10/23/2001)
- [Logic Selection Guide Second Half 2002 \(Rev. R\)](#) (SDYU001R, 4274 KB - Updated: 07/19/2002)
- [Military Semiconductors Selection Guide 2002 \(Rev. B\)](#) (SGYC003B, 1648 KB - Updated: 04/22/2002)

PRICING/AVAILABILITY/PKG

DEVICE INFORMATION							TI INVENTORY STATUS AS OF 3:00 PM GMT, 26 Sep 2002			REPORTED DISTRIBUTOR INVENTORY AS OF 3:00 PM GMT, 26 Sep 2002		
ORDERABLE DEVICE	STATUS	PACKAGE TYPE PINS	TEMP (°C)	PRODUCT CONTENT	BUDGETARY PRICING QTY SUS	STD PACK QTY	IN STOCK	IN PROGRESS QTY DATE	LEAD TIME	DISTRIBUTOR COMPANY REGION	IN STOCK	PURCHASE
SN74LS393D	ACTIVE	SOP (D) 14	0 TO 70	View Contents	1KU 0.46	50	N/A*		12 WKS			
SN74LS393DR	ACTIVE	SOP (D) 14	0 TO 70	View Contents	1KU 0.49	2500	N/A*		12 WKS			
SN74LS393J	OBSOLETE	CDIP (J) 14	0 TO 70	View Contents	1KU		N/A*		Not Available			
SN74LS393N	ACTIVE	PDIP (N) 14	0 TO 70	View Contents	1KU 0.41	25	N/A*		16 WKS	Avnet AMERICA	>1k	BUY NOW
										DigiKey AMERICA	317	BUY NOW
SN74LS393N3	OBSOLETE	PDIP (N) 14	0 TO 70	View Contents	1KU		N/A*		Not Available			
SN74LS393NSR	ACTIVE	SOP (NS) 14		View Contents	1KU 0.41	2000	N/A*		12 WKS			

Table Data Updated on: 9/26/2002