

RoHS

REV.	ECN NO.	DESCRIPTION	DESIGN	APPROVAL	DATE
A1	NEW	更换图框			2023.09.05

Electrical  
 Rated Voltage:60V AC  
 Current:0.5A  
 Contact Resistance:20mΩ . Max  
 Dielectric Withstanding Voltage:500V  
 Insulation Resistance:1000mΩ . Min  
 VSWR:  
 DC to 3GHz:1.3 max  
 3GHz to 6GHz:1.4 max  
 Physical  
 Housing :LCP,UL94V-0  
 Contact:Copper Alloy  
 Metal:Copper Alloy  
 Plating:Au or Ag  
 Operating Temperature:-20/ +85  
 Durability:30cycles  
 Solder joint peel strength:10N.min  
 Reference Information  
 Packaging:Reel  
 Quantity:3000Pcs/Reel

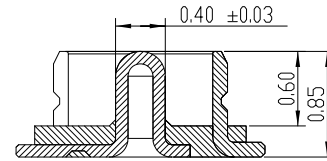
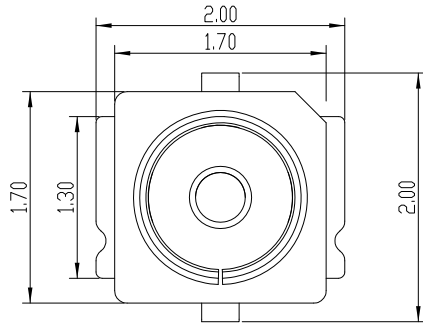

SECTION A-A

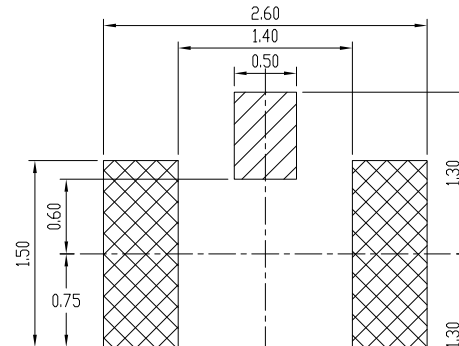
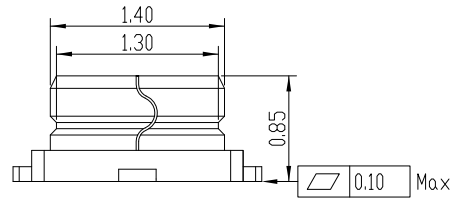

RECOMMENDED PCB LAYOUT  
 (TOLERANCE:±0.05)

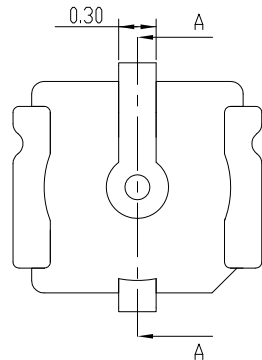

X.±0.50	X.°±
.X±0.25	.X°±
.XX± 0.15	.XX°±
.XXX±0.10	.XXX°±
UNITS:	mm

THESE DRAWINGS AND SPECIFICATIONS ARE THE PROPERTY OF XFCN AND SHALL NOT BE REPRODUCED, COPIED OR CUED IN ANY MANNER WITHOUT THE PRIOR WRITTEN CONSENT OF XFCN

PART NO.:	RF3200001R	<b>XFCN</b> 兴飞连接器			
TITLE:	超小型同轴连接器	0769-82001899			
		www.xfconn.com			
APPD:		DWG NO: /			
CHKD:			SCALE	SHEET	REV.
DRAW: Tong.Deng	2023.09.11		NONE	1/1	A1