

MB01S THRU MB10S

VOLTAGE RANGE	50 to 1000 Volts
CURRENT	1.0 Ampere

Features

- Glass passivated chip:45mil&50mil
- Glass passivated chip junction
- Ideal for surface mounted applications
- Low leakage
- High forward surge current capability
- High temperature soldering guaranteed:
260°C/10 seconds at terminals

Mechanical Data

- Case: Molded plastic body
- Epoxy: UL94V-0 rate flame retardant
- Polarity: Molded on body
- LeadP: Plated terminals solderable per MIL-STD-202E method 208C
- Weight: 0.04 ounce, 1.02 gram

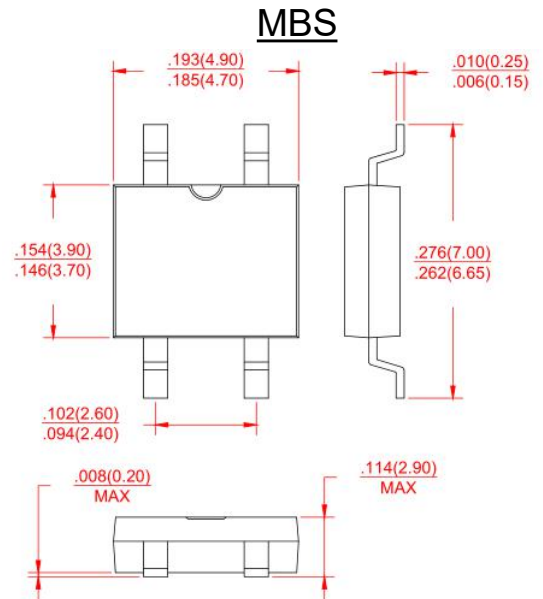

Dimensions in inches and (millimeters)

Maximum Ratings and Electrical Characteristics

- Ratings at 25°C ambient temperature unless otherwise specified
- Single Phase, half wave, 60Hz, resistive or inductive load
- For capacitive load derate current by 20%

TYPE NUMBER	SYMBOL	MB 01S	MB 02S	MB 03S	MB 04S	MB 06S	MB 08S	MB 10S	UNIT
Maximum Reverse Peak Repetitive Voltage	V_{RRM}	50	100	200	400	600	800	1000	Volts
Maximum RMS Voltage	V_{RMS}	35	70	140	280	420	560	700	Volts
Maximum DC Blocking Voltage	V_{DC}	50	100	200	400	600	800	1000	Volts
Maximum Average Forward Rectified Output Current, 0.06"(1.5mm) lead length at $T_A=100^\circ\text{C}$	$I_{(AV)}$	1.0							Amps
Peak Forward Surge Current 8.3ms single half sine wave superimposed on rated load (JEDEC Method)	I_{FSM}	30							Amps
Peak Forward Surge Current 1.0ms single half sine wave superimposed on rated load (JEDEC Method)		65							
Rating for Fusing ($t < 8.3\text{ms}$)	I^2t	3.7							A^2s
Maximum Instantaneous Forward Voltage drop Per Bridge element 1.0A	V_F	1.1							Volts
Maximum Reverse Current at rated DC blocking voltage per element	I_R	$T_A=25^\circ\text{C}$ 5							μAmps
		$T_A=125^\circ\text{C}$ 120							
Typical Junction Capacitance (NOTE 1)	C_J	25							pF
Typical Thermal Resistance (NOTE 2)	$R_{\theta JA}$	60							$^\circ\text{C}/\text{W}$
Operating and Storage Temperature Range	T_J, T_{STG}	(-55 to +150)							$^\circ\text{C}$

Notes:

1. Measured at 1.0MHz and applied reverse voltage of 4.0 Volts.
2. Unit mounted on P.C.B. with 0.033"x0.043"(1.00mm×1.30mm) copper pads.

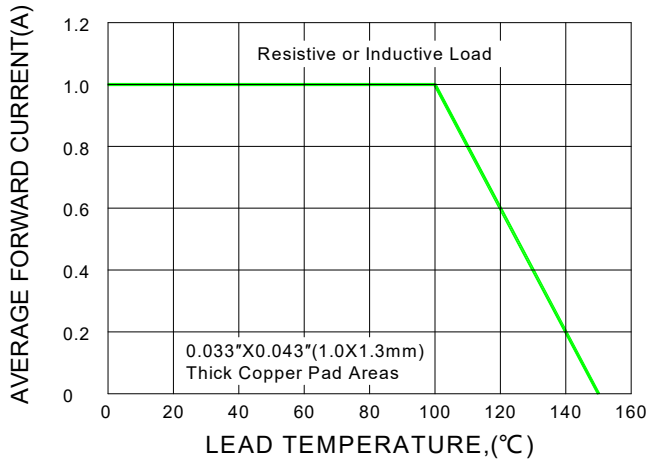
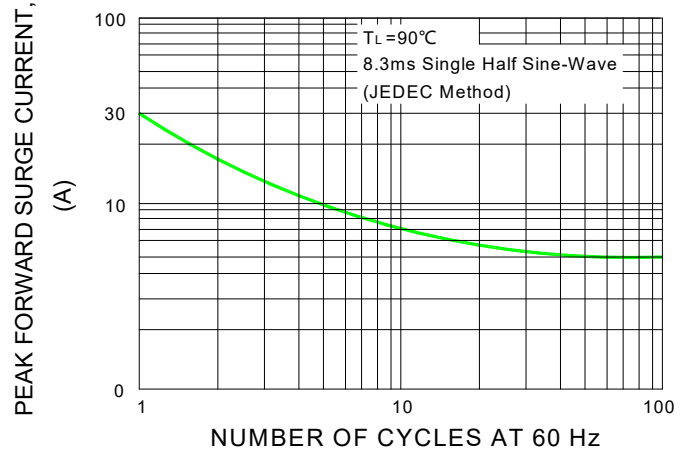
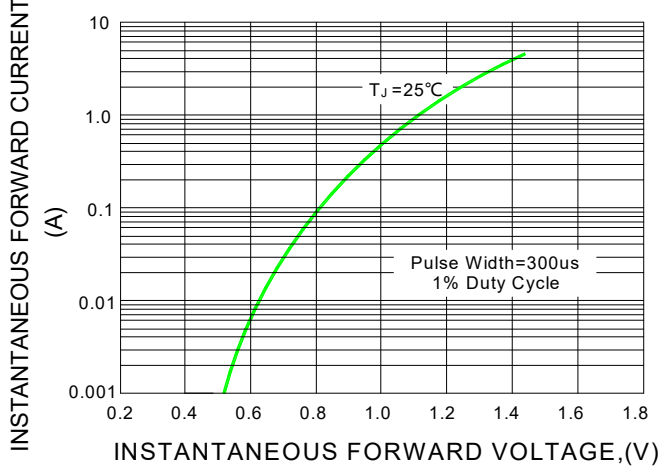
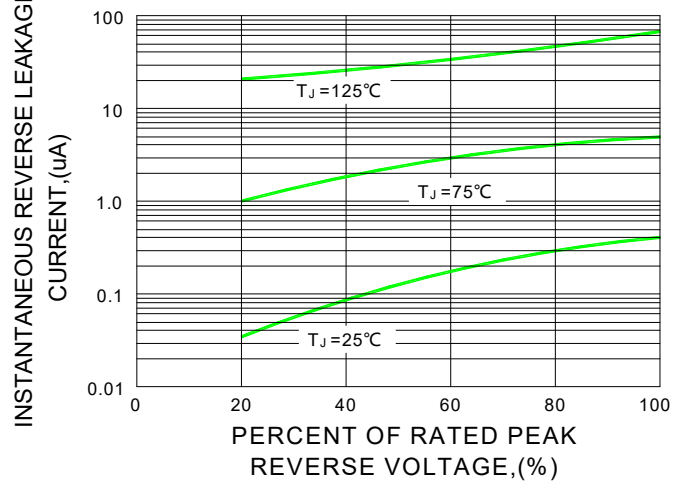
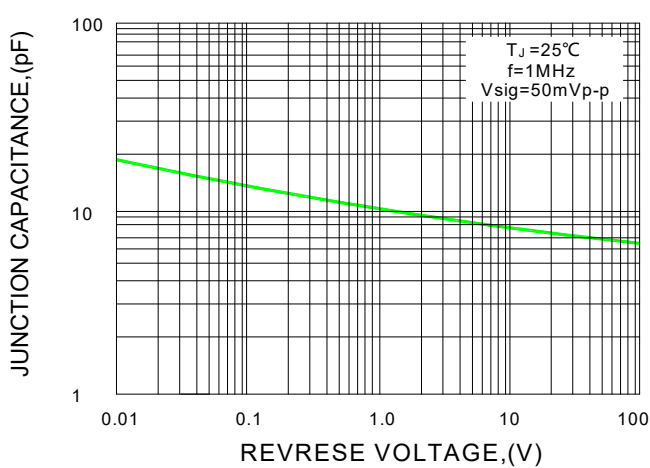
Ratings and Characteristic Curves (TA=25°C unless otherwise noted)
FIG.1-FORWARD CURRENT DERATING CURVE

FIG.2-MAXIMUM NON-REPETITIVE PEAK FORWARD SURGE CURRENT

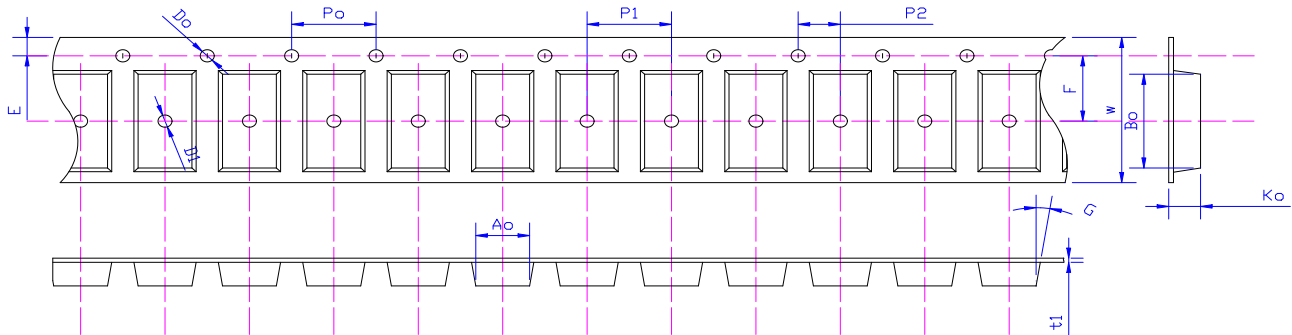
FIG.3-TYPICAL INSTANTANEOUS FORWARD CHARACTERISTICS

FIG.4-TYPICAL REVERSE CHARACTERISTICS

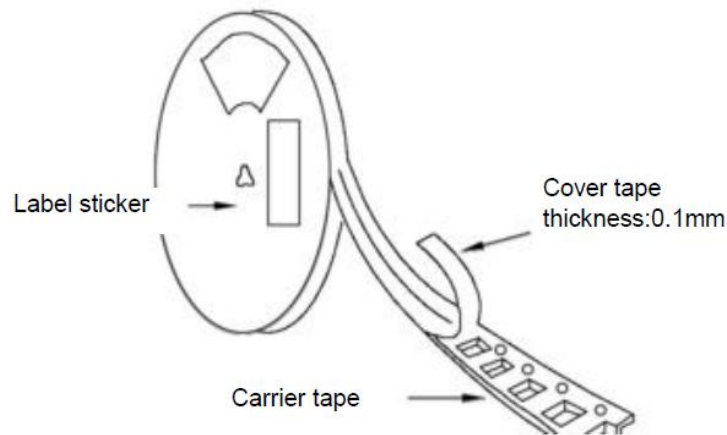
FIG.5-TYPICAL JUNCTION CAPACITANCE

Package Reel Information



Specifications	Ao	Bo	Ko	Po	W	t1
MBS	5.05±0.10	7.10±0.10	3.85±0.10	4.00±0.1	12.0±0.10	0.30±0.02

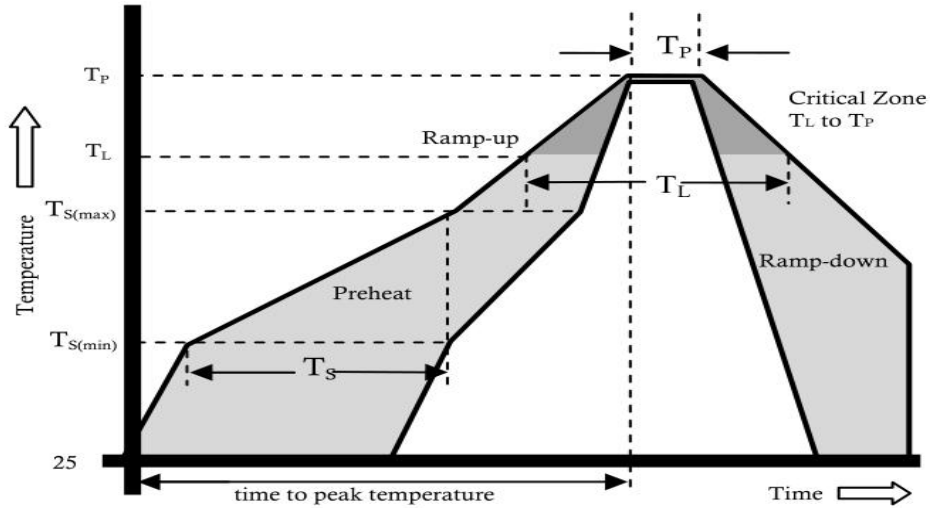

DEVICE TYPE	Tape Width	13"Reel			07"Reel			
		Q'TY/REEL(pcs)	BOX/CARTON	Q'TY/CARTON(pcs)	Q'TY/REEL(pcs)	REEL/BOX	BOX/CARTON	Q'TY/CARTON(pcs)
MBS	13mm	3000	8	24000	NA	NA	NA	NA

Reflow Profile

Reflow Condition		Pb-Free Assembly
Pre Heat	Temperature Min.	+150°C
	Temperature Max.	+200°C
	Time(Min to Max)	60-180 secs.
Average ramp up rate(Liquidus Temp(T_L) to peak)		3°C/sec. Max.
$T_{S(max)}$ to T_L - Ramp-up Rate		3°C/sec. Max.
Reflow	Temperature (T_L)(Liquidus)	+217°C
	Temperature (T_L)	60-150 secs.
Peak Temp (T_P)		+(260±0/-5) °C
Time within 5°C of actual Peak Temp (T_P)		25 secs.
Ramp-down Rate		6°C/sec. Max.
Time 25°C to peak Temp (T_P)		8 min. Max.
Do not exceed		+260°C