

SN74LVC2244 OCTAL BUFFER/DRIVER WITH 3-STATE OUTPUTS

SCAS572 – APRIL 1996

- **EPIC™ (Enhanced-Performance Implanted CMOS) Submicron Process**
- **Output Ports Have Equivalent 26-Ω Series Resistors, So No External Resistors Are Required**
- **Typical V_{OLP} (Output Ground Bounce) < 0.8 V at $V_{CC} = 3.3$ V, $T_A = 25^\circ\text{C}$**
- **Typical V_{OHV} (Output V_{OH} Undershoot) > 2 V at $V_{CC} = 3.3$ V, $T_A = 25^\circ\text{C}$**
- **Supports Mixed-Mode Signal Operation on All Ports (5-V Input/Output Voltage With 3.3-V V_{CC})**
- **ESD Protection Exceeds 2000 V Per MIL-STD-883C, Method 3015; Exceeds 200 V Using Machine Model ($C = 200$ pF, $R = 0$)**
- **Latch-Up Performance Exceeds 250 mA Per JEDEC Standard JESD-17**
- **Package Options Include Plastic Small-Outline (DW), Shrink Small-Outline (DB), and Thin Shrink Small-Outline (PW) Packages**

DB, DW, OR PW PACKAGE
(TOP VIEW)

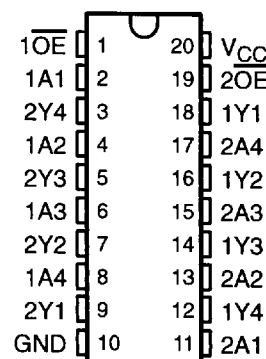

description

This octal buffer/line driver is designed for 2.7-V to 3.6-V V_{CC} operation; it can interface to a 5-V system environment.

The SN74LVC2244 is organized as two 4-bit line drivers with separate output-enable (\overline{OE}) inputs. When \overline{OE} is low, the device passes data from the A inputs to the Y outputs. When \overline{OE} is high, the outputs are in the high-impedance state.

The outputs, which are designed to sink up to 12 mA, include 26-Ω resistors to reduce overshoot and undershoot.

To ensure the high-impedance state during power up or power down, \overline{OE} should be tied to V_{CC} through a pullup resistor; the minimum value of the resistor is determined by the current-sinking capability of the driver.

The SN74LVC2244 is characterized for operation from -40°C to 85°C .

FUNCTION TABLE
(each buffer)

INPUTS		OUTPUT
\overline{OE}	A	Y
L	H	H
L	L	L
H	X	Z



Please be aware that an important notice concerning availability, standard warranty, and use in critical applications of Texas Instruments semiconductor products and disclaimers thereto appears at the end of this data sheet.

EPIC is a trademark of Texas Instruments Incorporated.

PRODUCTION DATA information is current as of publication date. Products conform to specifications per the terms of Texas Instruments standard warranty. Production processing does not necessarily include testing of all parameters.

 **TEXAS
INSTRUMENTS**

POST OFFICE BOX 655303 • DALLAS, TEXAS 75265

Copyright © 1996, Texas Instruments Incorporated

SN74LVC2244

OCTAL BUFFER/DRIVER WITH 3-STATE OUTPUTS

SCAS572 – APRIL 1996

logic symbol†

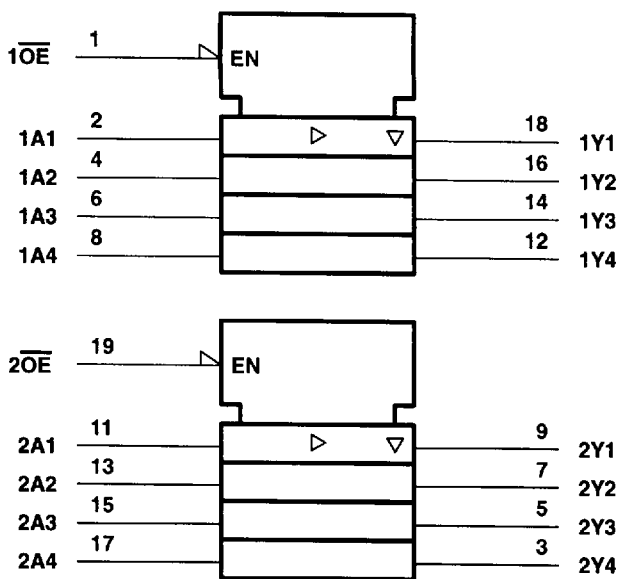

logic diagram (positive logic)

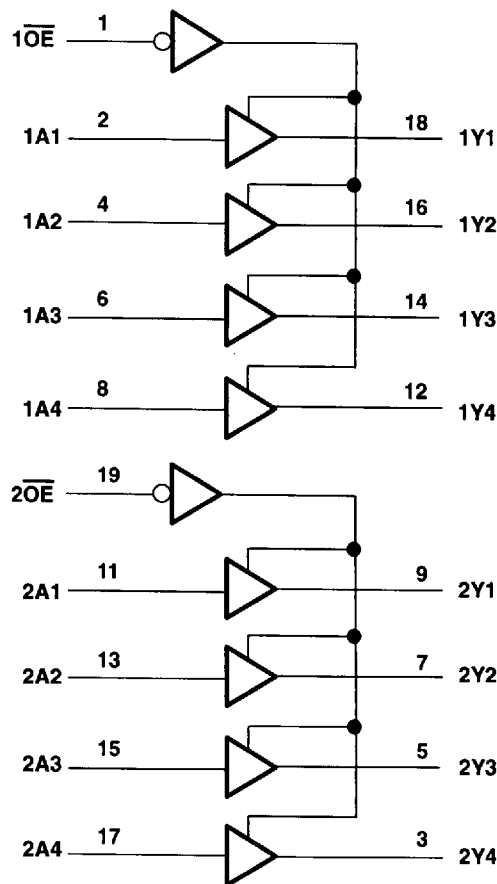

† This symbol is in accordance with ANSI/IEEE Std 91-1984 and IEC Publication 617-12.

absolute maximum ratings over operating free-air temperature range (unless otherwise noted)‡

Supply voltage range, V_{CC}	-0.5 V to 4.6 V
Input voltage range, V_I (see Note 1)	-0.5 V to 6.5 V
Voltage range applied to any output in the high-impedance state, V_O (see Note 1)	-0.5 V to 6.5 V
Voltage range applied to any output in the high or low state, V_O (see Notes 1 and 2)	-0.5 V to $V_{CC} + 0.5$ V
Input clamp current, I_{IK} ($V_I < 0$)	-50 mA
Output clamp current, I_{OK} ($V_O < 0$)	±50 mA
Continuous output current, I_O ($V_O = 0$ to V_{CC})	±50 mA
Continuous current through V_{CC} or GND	±100 mA
Maximum power dissipation at $T_A = 55^\circ\text{C}$ (in still air) (see Note 3):	
DB package	0.6 W
DW package	1.6 W
PW package	0.7 W
Storage temperature range, T_{stg}	-65°C to 150°C

‡ Stresses beyond those listed under "absolute maximum ratings" may cause permanent damage to the device. These are stress ratings only, and functional operation of the device at these or any other conditions beyond those indicated under "recommended operating conditions" is not implied. Exposure to absolute-maximum-rated conditions for extended periods may affect device reliability.

- NOTES:
1. The input and output negative-voltage ratings may be exceeded if the input and output clamp-current ratings are observed.
 2. This value is limited to 4.6 V maximum.
 3. The maximum package power dissipation is calculated using a junction temperature of 150°C and a board trace length of 750 mils. For more information, refer to the *Package Thermal Considerations* application note in the 1994 *ABT Advanced BiCMOS Technology Data Book*, literature number SCBD002B.



POST OFFICE BOX 655303 • DALLAS, TEXAS 75265

SN74LVC2244 OCTAL BUFFER/DRIVER WITH 3-STATE OUTPUTS

SCAS572 – APRIL 1996

recommended operating conditions (see Note 4)

			MIN	MAX	UNIT
V _{CC}	Supply voltage	Operating	2	3.6	V
		Data retention only	1.5		
V _{IH}	High-level input voltage	V _{CC} = 2.7 V to 3.6 V	2		V
V _{IL}	Low-level input voltage	V _{CC} = 2.7 V to 3.6 V		0.8	V
V _I	Input voltage		0	5.5	V
V _O	Output voltage	High or low state	0	V _{CC}	V
		3 state	0	5.5	
I _{OH}	High-level output current	V _{CC} = 2.7 V		-8	mA
		V _{CC} = 3 V		-12	
I _{OL}	Low-level output current	V _{CC} = 2.7 V		8	mA
		V _{CC} = 3 V		12	
Δt/Δv	Input transition rise or fall rate		0	10	ns/V
T _A	Operating free-air temperature		-40	85	°C

NOTE 4: Unused inputs must be held high or low to prevent them from floating.

electrical characteristics over recommended operating free-air temperature range (unless otherwise noted)

PARAMETER	TEST CONDITIONS	V _{CC} †	MIN	TYP‡	MAX	UNIT
V _{OH}	I _{OH} = -100 μA	MIN to MAX	V _{CC} -0.2			V
	I _{OH} = -4 mA	2.7 V	2.2			
	I _{OH} = -8 mA	2.7 V	2			
	I _{OH} = -6 mA	3 V	2.4			
	I _{OH} = -12 mA	3 V	2			
V _{OL}	I _{OL} = 100 μA	MIN to MAX			0.2	V
	I _{OL} = 4 mA	2.7 V			0.4	
	I _{OL} = 8 mA	2.7 V			0.6	
	I _{OL} = 6 mA	3 V			0.55	
	I _{OL} = 12 mA	3 V			0.8	
I _I	V _I = 5.5 V or GND	3.6 V			±5	μA
I _{OZ}	V _O = 5.5 V or GND	3.6 V			±10	μA
	V _O = 3.6 V or 5.5 V	MIN to MAX			±50	
I _{CC}	V _I = V _{CC} or GND, I _O = 0	3.6 V			10	μA
ΔI _{CC}	One input at V _{CC} - 0.6 V, Other inputs at V _{CC} or GND	2.7 V to 3.6 V			500	μA
C _i	V _I = V _{CC} or GND	3.3 V		3.1		pF
C _o	V _O = V _{CC} or GND	3.3 V		5		pF

† For conditions shown as MIN or MAX, use the appropriate values under recommended operating conditions.

‡ All typical values are measured at V_{CC} = 3.3 V, T_A = 25°C.



POST OFFICE BOX 655303 • DALLAS, TEXAS 75265

8961723 0105232 656

SN74LVC2244
OCTAL BUFFER/DRIVER
WITH 3-STATE OUTPUTS

SCAS572 – APRIL 1996

switching characteristics over recommended operating free-air temperature range, $C_L = 50$ pF (unless otherwise noted) (see Figure 1)

PARAMETER	FROM (INPUT)	TO (OUTPUT)	$V_{CC} = 3.3$ V ± 0.3 V		$V_{CC} = 2.7$ V		UNIT
			MIN	MAX	MIN	MAX	
t_{pd}	A	Y	1.5	7.5	8.5		ns
t_{en}	\overline{OE}	Y	1.5	9	10		ns
t_{dis}	\overline{OE}	Y	1.5	7	8		ns
$t_{sk(o)}^\dagger$			1				ns

† Skew between any two outputs of the same package switching in the same direction. This parameter is warranted but not production tested.

operating characteristics, $V_{CC} = 3.3$ V, $T_A = 25^\circ\text{C}$

PARAMETER		TEST CONDITIONS	TYP	UNIT
C_{pd}	Power dissipation capacitance per buffer/driver	$C_L = 50$ pF, $f = 10$ MHz	30	pF
			2	



POST OFFICE BOX 655303 • DALLAS, TEXAS 75265

PARAMETER MEASUREMENT INFORMATION

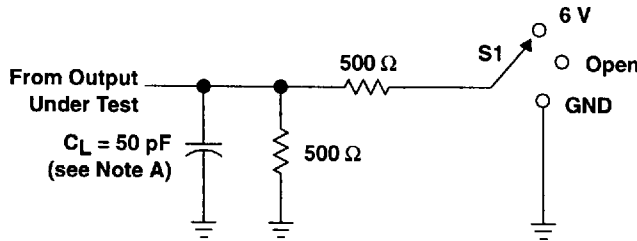

LOAD CIRCUIT FOR OUTPUTS

TEST	S1
t_{pd}	Open
t_{PLZ}/t_{PZL}	6 V
t_{PHZ}/t_{PZH}	GND

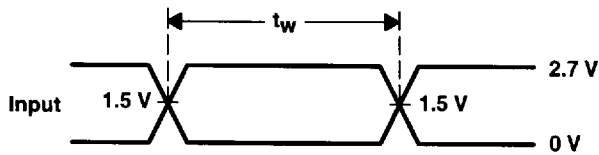

VOLTAGE WAVEFORMS
PULSE DURATION

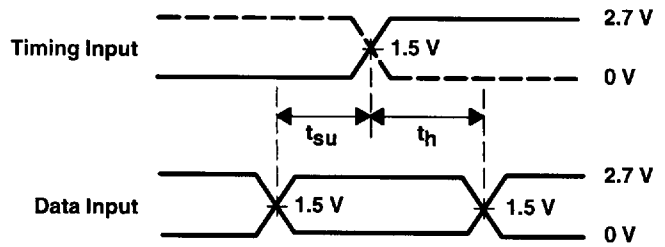

VOLTAGE WAVEFORMS
SETUP AND HOLD TIMES

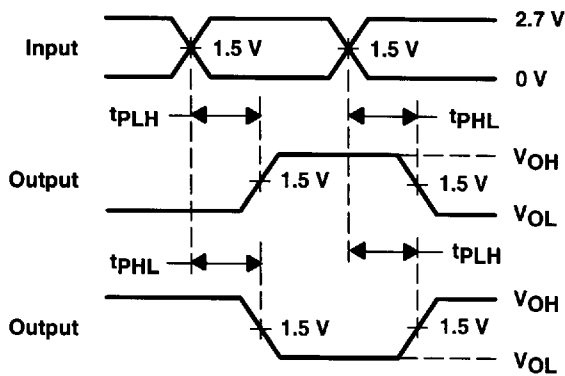

VOLTAGE WAVEFORMS
PROPAGATION DELAY TIMES
INVERTING AND NONINVERTING OUTPUTS

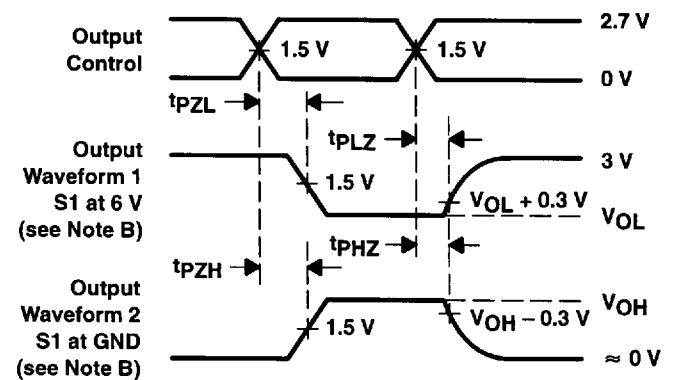

VOLTAGE WAVEFORMS
ENABLE AND DISABLE TIMES
LOW- AND HIGH-LEVEL ENABLING

- NOTES: A. C_L includes probe and jig capacitance.
B. Waveform 1 is for an output with internal conditions such that the output is low except when disabled by the output control. Waveform 2 is for an output with internal conditions such that the output is high except when disabled by the output control.
C. All input pulses are supplied by generators having the following characteristics: $PRR \leq 10$ MHz, $Z_O = 50 \Omega$, $t_r \leq 2.5$ ns, $t_f \leq 2.5$ ns.
D. The outputs are measured one at a time with one transition per measurement.
E. t_{PLZ} and t_{PHZ} are the same as t_{dis} .
F. t_{PZL} and t_{PZH} are the same as t_{en} .
G. t_{PLH} and t_{PHL} are the same as t_{pd} .

Figure 1. Load Circuit and Voltage Waveforms