

SN74ALB16244 16-BIT BUFFER/DRIVER WITH 3-STATE OUTPUTS

SCBS647C – AUGUST 1995 – REVISED JULY 1997

- Member of the Texas Instruments *Widebus*™ Family
- State-of-the-Art Advanced Low-Voltage BiCMOS (ALB) Technology Design for 3.3-V Operation
- Schottky Diodes on All Inputs to Eliminate Overshoot and Undershoot
- Industry Standard '16244 Pinout
- Distributed V_{CC} and GND Pin Configuration Minimizes High-Speed Switching Noise
- Flow-Through Architecture Optimizes PCB Layout
- Package Options Include Plastic 300-mil Shrink Small-Outline (DL) and Thin Shrink Small-Outline (DGG) Packages

description

The SN74ALB16244 16-bit buffer and line driver is designed for high-speed, low-voltage (3.3-V) V_{CC} operation. This device is intended to replace the conventional driver in any speed-critical path. The small propagation delay is achieved using a unity gain amplifier on the input and feedback resistors from input to output, which allows the output to track the input with a small offset voltage.

The device can be used as four 4-bit buffers, two 8-bit buffers, or one 16-bit buffer. This device provides true outputs and symmetrical active-low output-enable (\overline{OE}) inputs.

The SN74ALB16244 is characterized for operation from –40°C to 85°C.

DGG OR DL PACKAGE (TOP VIEW)

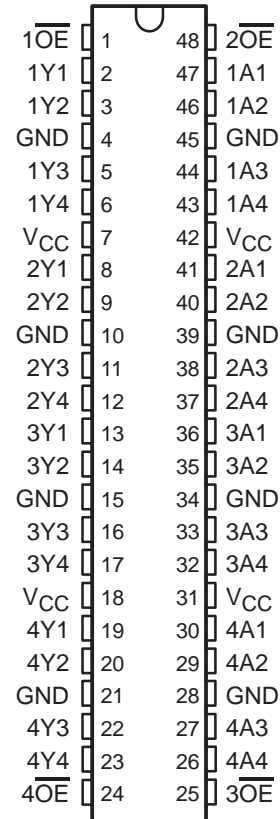

FUNCTION TABLE
(each buffer)

INPUTS		OUTPUT
\overline{OE}	A	Y
L	H	H
L	L	L
H	X	Z



Please be aware that an important notice concerning availability, standard warranty, and use in critical applications of Texas Instruments semiconductor products and disclaimers thereto appears at the end of this data sheet.

Widebus is a trademark of Texas Instruments Incorporated.

PRODUCTION DATA information is current as of publication date. Products conform to specifications per the terms of Texas Instruments standard warranty. Production processing does not necessarily include testing of all parameters.



POST OFFICE BOX 655303 • DALLAS, TEXAS 75265

Copyright © 1997, Texas Instruments Incorporated

SN74ALB16244
16-BIT BUFFER/DRIVER
WITH 3-STATE OUTPUTS
 SCBS647C – AUGUST 1995 – REVISED JULY 1997

logic symbol†

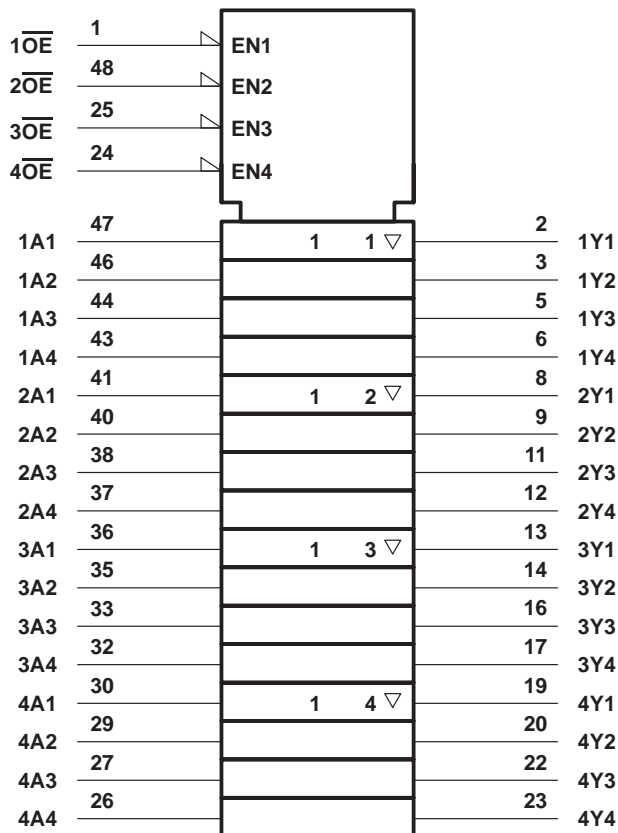

† This symbol is in accordance with ANSI/IEEE Std 91-1984 and IEC Publication 617-12.

logic diagram (positive logic)

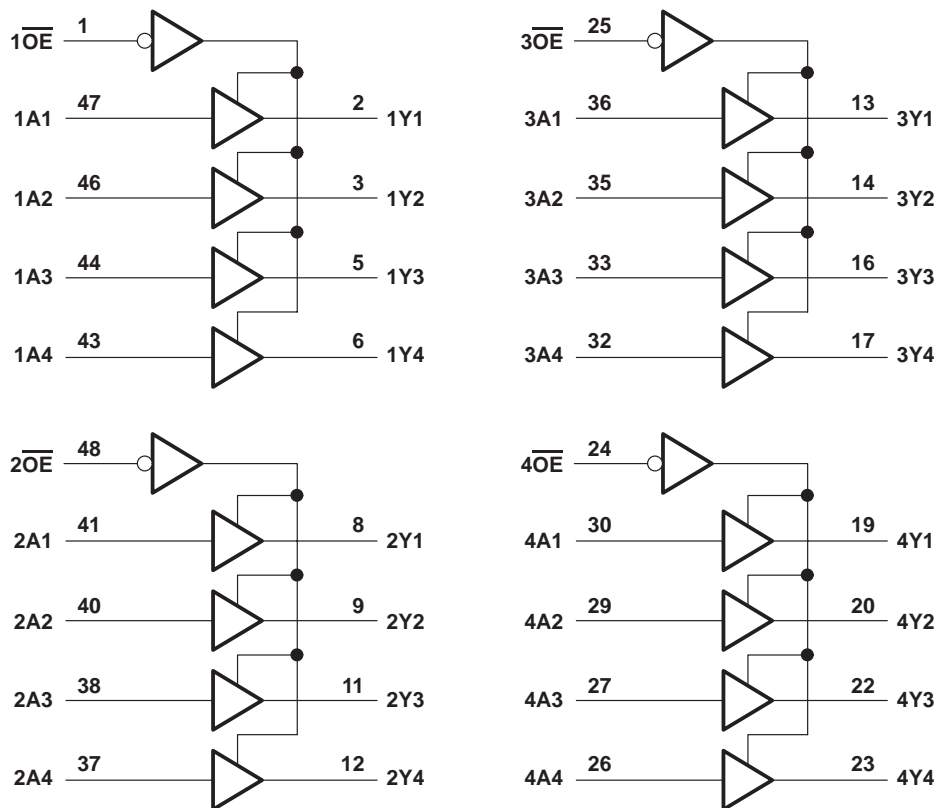

absolute maximum ratings over operating free-air temperature range (unless otherwise noted)†

Supply voltage range, V_{CC}	-0.5 V to 4.6 V
Input voltage range, V_I : Except I/O ports (see Note 1)	-0.5 V to 4.6 V
I/O ports (see Notes 1 and 2)	-0.5 V to $V_{CC} + 0.5$ V
Output voltage range, V_O (see Notes 1 and 2)	-0.5 V to $V_{CC} + 0.5$ V
Input clamp current, I_{IK} ($V_I < 0$)	-50 mA
Output clamp current, I_{OK} ($V_O < 0$ or $V_O > V_{CC}$)	± 50 mA
Continuous output current, I_O ($V_O = 0$ to V_{CC})	± 50 mA
Continuous current through each V_{CC} or GND	± 100 mA
Package thermal impedance, θ_{JA} (see Note 3): DGG package	89°C/W
DL package	94°C/W
Storage temperature range, T_{stg}	-65°C to 150°C

† Stresses beyond those listed under “absolute maximum ratings” may cause permanent damage to the device. These are stress ratings only, and functional operation of the device at these or any other conditions beyond those indicated under “recommended operating conditions” is not implied. Exposure to absolute-maximum-rated conditions for extended periods may affect device reliability.

- NOTES: 1. The input and output negative-voltage ratings may be exceeded if the input and output clamp-current ratings are observed.
2. This value is limited to 4.6 V maximum.
3. The package thermal impedance is calculated in accordance with JESD 51.

SN74ALB16244
16-BIT BUFFER/DRIVER
WITH 3-STATE OUTPUTS

SCBS647C – AUGUST 1995 – REVISED JULY 1997

recommended operating conditions

		MIN	MAX	UNIT
V_{CC}	Supply voltage	3	3.6	V
I_{OH}^{\dagger}	High-level output current		-25	mA
I_{OL}^{\dagger}	Low-level output current		25	mA
$\Delta t/\Delta v$	Input transition rise or fall rate	Outputs enabled		5 ns/V
T_A	Operating free-air temperature	-40	85	°C

[†] Refer to Figures 1 and 2 for typical I/O ranges.

electrical characteristics over recommended operating free-air temperature range (unless otherwise noted)

PARAMETER		TEST CONDITIONS		MIN	TYP [‡]	MAX	UNIT	
V_{IK}	Data inputs	$V_{CC} = 3\text{ V}$	$I_I = 18\text{ mA}$	3.6	$V_{CC}-1.2$		V	
			$I_I = -18\text{ mA}$	-0.9	-1.2			
I_I	Control inputs	$V_{CC} = 3.6\text{ V}$,	$V_I = V_{CC}$ or GND			±10	µA	
	Data inputs	$V_{CC} = 3.6\text{ V}$	$V_I = V_{CC}$	\overline{OE} low	0.4	0.6	mA	
				\overline{OE} high		25	µA	
			$V_I = 0$	\overline{OE} low	-0.8	-1	mA	
\overline{OE} high		-60		µA				
I_{OZH}		$V_{CC} = 3.6\text{ V}$,	$V_O = 3\text{ V}$	0.6		20	µA	
I_{OZL}		$V_{CC} = 3.6\text{ V}$,	$V_O = 0.5\text{ V}$	-0.1		-50	µA	
I_{CC}/buffer		$V_{CC} = 3.6\text{ V}$,	$I_O = 0$,			3.7	5.6	mA
I_{CCZ}		$V_{CC} = 3.6\text{ V}$,	Control inputs = V_{CC} or GND				0.8	mA
ΔI_{CC}^{\S}		$V_{CC} = 3\text{ V}$ to 3.6 V , One input at $V_{CC} - 0.6\text{ V}$, Other inputs at V_{CC} or GND					600	µA
C_i		$V_I = 3\text{ V}$ or 0				4.5		pF
C_o		$V_O = 3\text{ V}$ or 0				5.5		pF

[‡] All typical values are at $V_{CC} = 3.3\text{ V}$, $T_A = 25^\circ\text{C}$.

[§] This is the increase in supply current for each input that is at the specified TTL voltage level rather than V_{CC} or GND.

switching characteristics over recommended operating free-air temperature range, $C_L = 50\text{ pF}$ (unless otherwise noted) (see Figure 3)

PARAMETER	FROM (INPUT)	TO (OUTPUT)	$V_{CC} = 3.3\text{ V} \pm 0.3\text{ V}$			UNIT
			MIN	TYP [‡]	MAX	
t_{pd}	A	Y	0.6	1.3	2	ns
t_{en}	\overline{OE}	Y	1.3	2.5	4.7	ns
t_{dis}	\overline{OE}	Y	1.8	2.8	4.2	ns

[‡] All typical values are at $V_{CC} = 3.3\text{ V}$, $T_A = 25^\circ\text{C}$.



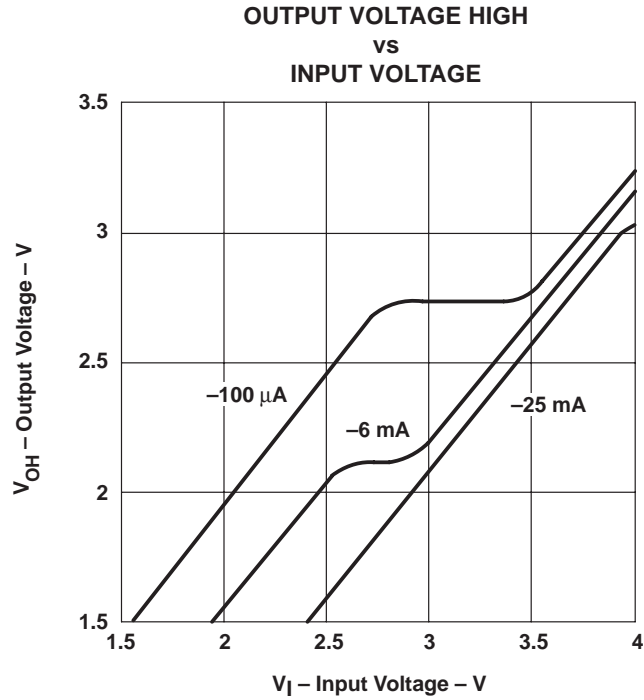

Figure 1. V_{OH} Over Recommended Free-Air Temperature Range

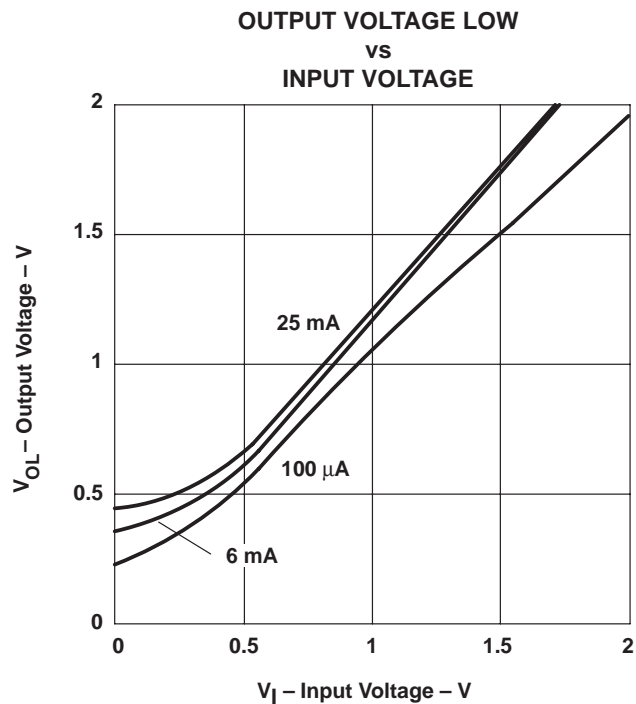
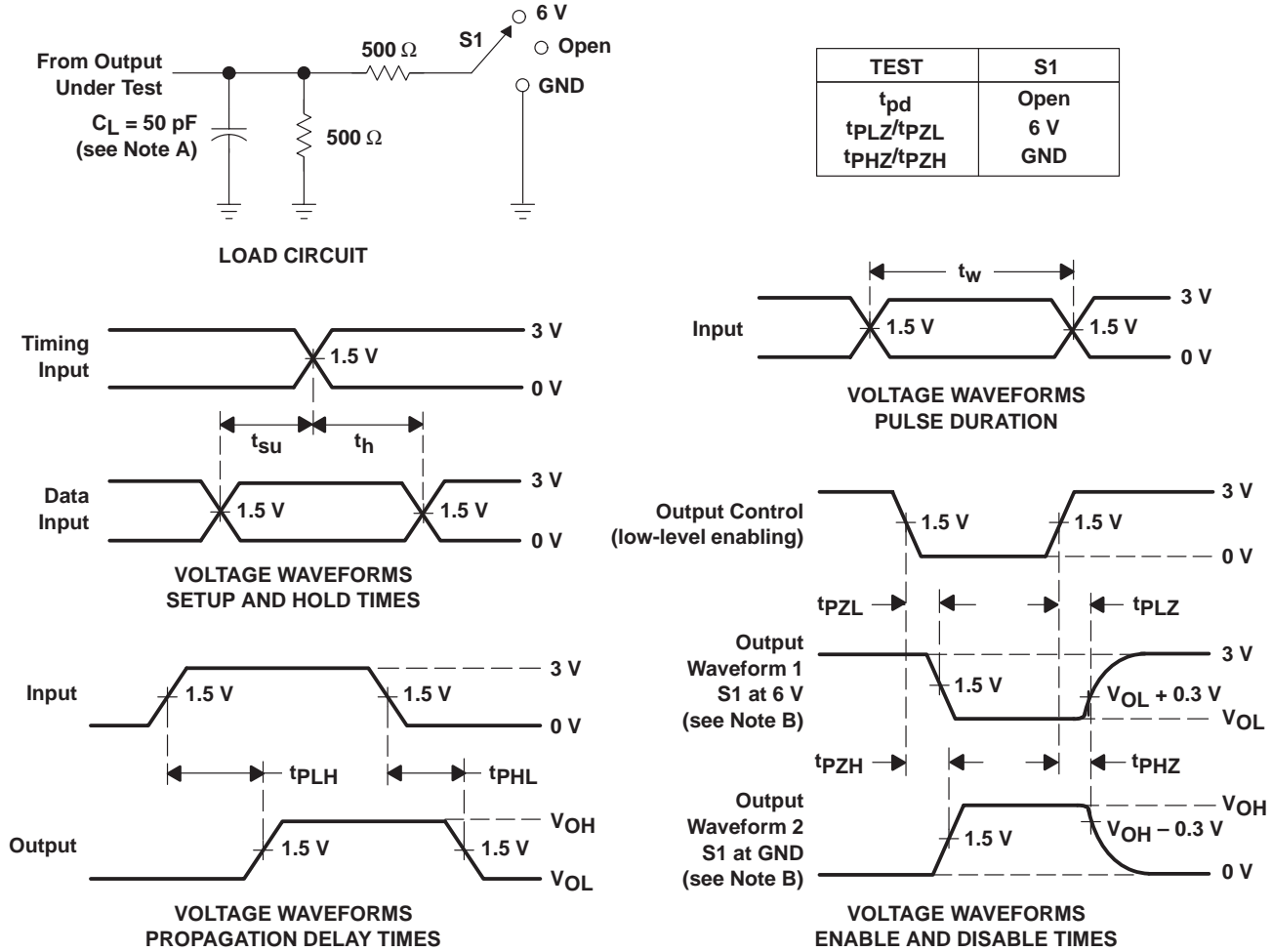

Figure 2. V_{OL} Over Recommended Free-Air Temperature Range

SN74ALB16244
16-BIT BUFFER/DRIVER
WITH 3-STATE OUTPUTS

SCBS647C – AUGUST 1995 – REVISED JULY 1997

PARAMETER MEASUREMENT INFORMATION



- NOTES:
- A. C_L includes probe and jig capacitance.
 - B. Waveform 1 is for an output with internal conditions such that the output is low except when disabled by the output control. Waveform 2 is for an output with internal conditions such that the output is high except when disabled by the output control.
 - C. All input pulses are supplied by generators having the following characteristics: $PRR \leq 10 \text{ MHz}$, $Z_O = 50 \Omega$, $t_r \leq 2.5 \text{ ns}$, $t_f \leq 2.5 \text{ ns}$.
 - D. The outputs are measured one at a time with one transition per measurement.
 - E. t_{PLZ} and t_{PHZ} are the same as t_{dis} .
 - F. t_{PZL} and t_{PZH} are the same as t_{en} .
 - G. t_{PLH} and t_{PHL} are the same as t_{pd} .

Figure 3. Load Circuit and Voltage Waveforms

IMPORTANT NOTICE

Texas Instruments and its subsidiaries (TI) reserve the right to make changes to their products or to discontinue any product or service without notice, and advise customers to obtain the latest version of relevant information to verify, before placing orders, that information being relied on is current and complete. All products are sold subject to the terms and conditions of sale supplied at the time of order acknowledgement, including those pertaining to warranty, patent infringement, and limitation of liability.

TI warrants performance of its semiconductor products to the specifications applicable at the time of sale in accordance with TI's standard warranty. Testing and other quality control techniques are utilized to the extent TI deems necessary to support this warranty. Specific testing of all parameters of each device is not necessarily performed, except those mandated by government requirements.

CERTAIN APPLICATIONS USING SEMICONDUCTOR PRODUCTS MAY INVOLVE POTENTIAL RISKS OF DEATH, PERSONAL INJURY, OR SEVERE PROPERTY OR ENVIRONMENTAL DAMAGE ("CRITICAL APPLICATIONS"). TI SEMICONDUCTOR PRODUCTS ARE NOT DESIGNED, AUTHORIZED, OR WARRANTED TO BE SUITABLE FOR USE IN LIFE-SUPPORT DEVICES OR SYSTEMS OR OTHER CRITICAL APPLICATIONS. INCLUSION OF TI PRODUCTS IN SUCH APPLICATIONS IS UNDERSTOOD TO BE FULLY AT THE CUSTOMER'S RISK.

In order to minimize risks associated with the customer's applications, adequate design and operating safeguards must be provided by the customer to minimize inherent or procedural hazards.

TI assumes no liability for applications assistance or customer product design. TI does not warrant or represent that any license, either express or implied, is granted under any patent right, copyright, mask work right, or other intellectual property right of TI covering or relating to any combination, machine, or process in which such semiconductor products or services might be or are used. TI's publication of information regarding any third party's products or services does not constitute TI's approval, warranty or endorsement thereof.