

# SN54ABT244, SN74ABT244 OCTAL BUFFERS/DRIVERS WITH 3-STATE OUTPUTS

SCBS099E – JANUARY 1991 – REVISED JULY 1994

- State-of-the-Art *EPIC-II B™* BiCMOS Design Significantly Reduces Power Dissipation
- Latch-Up Performance Exceeds 500 mA Per JEDEC Standard JESD-17
- Typical  $V_{OLP}$  (Output Ground Bounce)  $< 1$  V at  $V_{CC} = 5$  V,  $T_A = 25^\circ\text{C}$
- High-Drive Outputs ( $-32\text{-mA } I_{OH}$ ,  $64\text{-mA } I_{OL}$ )
- Package Options Include Plastic Small-Outline (DW), Shrink Small-Outline (DB), and Thin Shrink Small-Outline (PW) Packages, Ceramic Chip Carriers (FK), and Plastic (N) and Ceramic (J) DIPs

SN54ABT244 . . . J PACKAGE  
SN74ABT244 . . . DB, DW, N, OR PW PACKAGE  
(TOP VIEW)

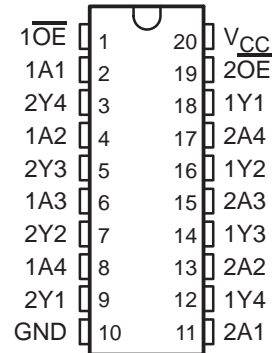

## description

These octal buffers and line drivers are designed specifically to improve both the performance and density of 3-state memory address drivers, clock drivers, and bus-oriented receivers and transmitters. Taken together with the 'ABT240 and 'ABT241, these devices provide the choice of selected combinations of inverting and noninverting outputs, symmetrical active-low output-enable ( $\overline{OE}$ ) inputs, and complementary OE and  $\overline{OE}$  inputs.

The 'ABT244 is organized as two 4-bit buffers/line drivers with separate  $\overline{OE}$  inputs. When  $\overline{OE}$  is low, the device passes data from the A inputs to the Y outputs. When  $\overline{OE}$  is high, the outputs are in the high-impedance state.

To ensure the high-impedance state during power up or power down,  $\overline{OE}$  should be tied to  $V_{CC}$  through a pullup resistor; the minimum value of the resistor is determined by the current-sinking capability of the driver.

The SN74ABT244 is available in TI's shrink small-outline package (DB), which provides the same I/O pin count and functionality of standard small-outline packages in less than half the printed-circuit-board area.

The SN54ABT244 is characterized for operation over the full military temperature range of  $-55^\circ\text{C}$  to  $125^\circ\text{C}$ . The SN74ABT244 is characterized for operation from  $-40^\circ\text{C}$  to  $85^\circ\text{C}$ .

SN54ABT244 . . . FK PACKAGE  
(TOP VIEW)

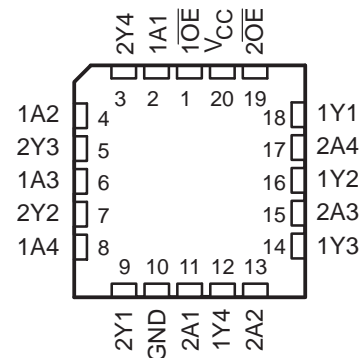

FUNCTION TABLE  
(each buffer)

INPUTS		OUTPUT
$\overline{OE}$	A	Y
L	H	H
L	L	L
H	X	Z

EPIC-II B is a trademark of Texas Instruments Incorporated.

PRODUCTION DATA information is current as of publication date. Products conform to specifications per the terms of Texas Instruments standard warranty. Production processing does not necessarily include testing of all parameters.

 **TEXAS  
INSTRUMENTS**

POST OFFICE BOX 655303 • DALLAS, TEXAS 75265

Copyright © 1994, Texas Instruments Incorporated

# SN54ABT244, SN74ABT244 OCTAL BUFFERS/DRIVERS WITH 3-STATE OUTPUTS

SCBS099E – JANUARY 1991 – REVISED JULY 1994

## logic symbol†

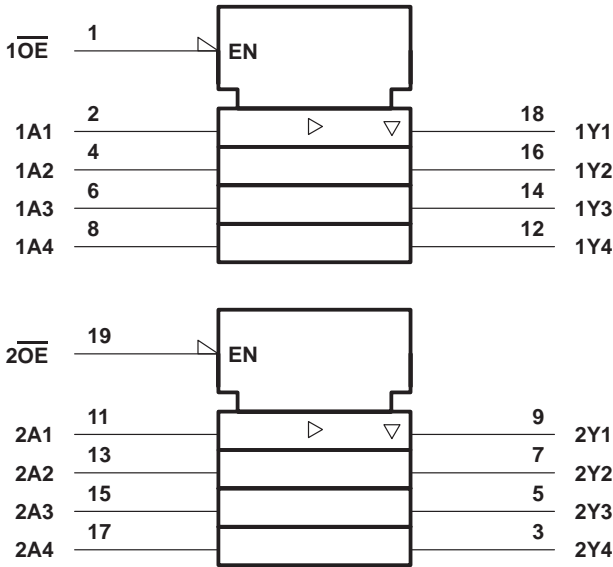

† This symbol is in accordance with ANSI/IEEE Std 91-1984 and IEC Publication 617-12.

## logic diagram (positive logic)

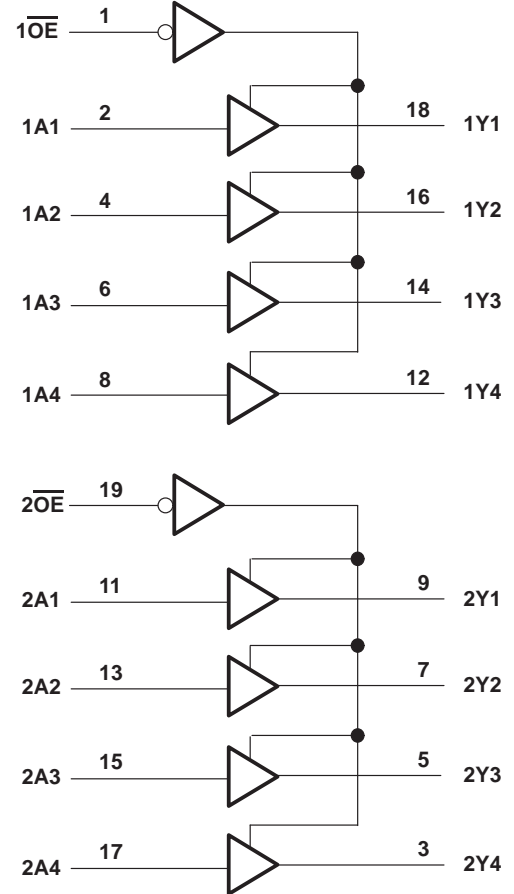

## absolute maximum ratings over operating free-air temperature range (unless otherwise noted)‡

Supply voltage range, $V_{CC}$ .....	-0.5 V to 7 V
Input voltage range, $V_I$ (see Note 1) .....	-0.5 V to 7 V
Voltage applied to any output in the high state or power-off state, $V_O$ .....	-0.5 V to 5.5 V
Current into any output in the low state, $I_{OL}$ : SN54ABT244 .....	96 mA
SN74ABT244 .....	128 mA
Input clamp current, $I_{IK}$ ( $V_I < 0$ ) .....	-18 mA
Output clamp current, $I_{OK}$ ( $V_O < 0$ ) .....	-50 mA
Maximum power dissipation at $T_A = 55^\circ\text{C}$ (in still air) (see Note 2): DB package .....	0.6 W
DW package .....	1.6 W
N package .....	1.3 W
PW package .....	0.7 W
Storage temperature range .....	$-65^\circ\text{C}$ to $150^\circ\text{C}$

‡ Stresses beyond those listed under "absolute maximum ratings" may cause permanent damage to the device. These are stress ratings only, and functional operation of the device at these or any other conditions beyond those indicated under "recommended operating conditions" is not implied. Exposure to absolute-maximum-rated conditions for extended periods may affect device reliability.

- NOTES: 1. The input and output negative-voltage ratings may be exceeded if the input and output clamp-current ratings are observed.  
 2. The maximum package power dissipation is calculated using a junction temperature of  $150^\circ\text{C}$  and a board trace length of 750 mils, except for the N package, which has a trace length of zero. For more information, refer to the *Package Thermal Considerations* application note in the 1994 *ABT Advanced BiCMOS Technology Data Book*, literature number SCBD002B.

# SN54ABT244, SN74ABT244 OCTAL BUFFERS/DRIVERS WITH 3-STATE OUTPUTS

SCBS099E – JANUARY 1991 – REVISED JULY 1994

## recommended operating conditions (see Note 3)

		SN54ABT244		SN74ABT244		UNIT
		MIN	MAX	MIN	MAX	
$V_{CC}$	Supply voltage	4.5	5.5	4.5	5.5	V
$V_{IH}$	High-level input voltage	2		2		V
$V_{IL}$	Low-level input voltage		0.8		0.8	V
$V_I$	Input voltage	0	$V_{CC}$	0	$V_{CC}$	V
$I_{OH}$	High-level output current		-24		-32	mA
$I_{OL}$	Low-level output current		48		64	mA
$\Delta t/\Delta v$	Input transition rise or fall rate		5		5	ns/V
$T_A$	Operating free-air temperature	-55	125	-40	85	°C

NOTE 3: Unused or floating inputs must be held high or low.

## electrical characteristics over recommended operating free-air temperature range (unless otherwise noted)

PARAMETER	TEST CONDITIONS	$T_A = 25^\circ\text{C}$			SN54ABT244		SN74ABT244		UNIT	
		MIN	TYP†	MAX	MIN	MAX	MIN	MAX		
$V_{IK}$	$V_{CC} = 4.5\text{ V}$ , $I_I = -18\text{ mA}$			-1.2	-1.2			-1.2	V	
$V_{OH}$	$V_{CC} = 4.5\text{ V}$ , $I_{OH} = -3\text{ mA}$	2.5			2.5			2.5	V	
	$V_{CC} = 5\text{ V}$ , $I_{OH} = -3\text{ mA}$	3			3			3		
	$V_{CC} = 4.5\text{ V}$	$I_{OH} = -24\text{ mA}$	2			2				
		$I_{OH} = -32\text{ mA}$	2*					2		
$V_{OL}$	$V_{CC} = 4.5\text{ V}$	$I_{OL} = 48\text{ mA}$		0.55	0.55				V	
		$I_{OL} = 64\text{ mA}$		0.55*			0.55			
$I_I$	$V_{CC} = 5.5\text{ V}$ , $V_I = V_{CC}$ or GND			$\pm 1$		$\pm 1$		$\pm 1$	$\mu\text{A}$	
$I_{OZH}$	$V_{CC} = 5.5\text{ V}$ , $V_O = 2.7\text{ V}$			$10^\ddagger$		$10^\ddagger$		$10^\ddagger$	$\mu\text{A}$	
$I_{OZL}$	$V_{CC} = 5.5\text{ V}$ , $V_O = 0.5\text{ V}$			$-10^\ddagger$		$-10^\ddagger$		$-10^\ddagger$	$\mu\text{A}$	
$I_{off}$	$V_{CC} = 0$ , $V_I$ or $V_O \leq 4.5\text{ V}$			$\pm 100$				$\pm 100$	$\mu\text{A}$	
$I_{CEX}$	$V_{CC} = 5.5\text{ V}$ , $V_O = 5.5\text{ V}$   Outputs high			50		50		50	$\mu\text{A}$	
$I_{O\S}$	$V_{CC} = 5.5\text{ V}$ , $V_O = 2.5\text{ V}$	-50	-100	-180	-50	-180	-50	-180	mA	
$I_{CC}$	$V_{CC} = 5.5\text{ V}$ , $V_I = V_{CC}$ or GND	$I_O = 0$ ,	Outputs high	1	250		250	250	$\mu\text{A}$	
			Outputs low	24	30		30	30	mA	
			Outputs disabled	0.5	250		250	250	$\mu\text{A}$	
$\Delta I_{CC}^\parallel$	$V_{CC} = 5.5\text{ V}$ , One input at 3.4 V, Other inputs at $V_{CC}$ or GND	Data inputs	Outputs enabled		1.5		1.5	1.5	mA	
			Outputs disabled		0.05		0.05	0.05		
		Control inputs		1.5		1.5	1.5			
$C_i$	$V_I = 2.5\text{ V}$ or $0.5\text{ V}$			3					pF	
$C_o$	$V_O = 2.5\text{ V}$ or $0.5\text{ V}$			8					pF	

\* On products compliant to MIL-STD-883, Class B, this parameter does not apply.

† All typical values are at  $V_{CC} = 5\text{ V}$ .

‡ This data sheet limit may vary among suppliers.

§ Not more than one output should be tested at a time, and the duration of the test should not exceed one second.

¶ This is the increase in supply current for each input that is at the specified TTL voltage level rather than  $V_{CC}$  or GND.

**SN54ABT244, SN74ABT244**  
**OCTAL BUFFERS/DRIVERS**  
**WITH 3-STATE OUTPUTS**

SCBS099E – JANUARY 1991 – REVISED JULY 1994

switching characteristics over recommended ranges of supply voltage and operating free-air temperature,  $C_L = 50$  pF (unless otherwise noted) (see Figure 1)

PARAMETER	FROM (INPUT)	TO (OUTPUT)	$V_{CC} = 5$ V, $T_A = 25^\circ$ C			SN54ABT244		SN74ABT244		UNIT
			MIN	TYP	MAX	MIN	MAX	MIN	MAX	
$t_{PLH}$	A	Y	1	2.6	4.1	1	5.3	1	4.6	ns
$t_{PHL}$			1	2.9	4.2	1	5	1	4.6	
$t_{PZH}$	$\overline{OE}$	Y	1.1	3.1	4.6	0.8	5.7	1.1	5.1	ns
$t_{PZL}$			2.1	4.1	5.6	1.2	7.9	2.1	6.1	
$t_{PHZ}$	$\overline{OE}$	Y	2.1	4.1	5.6	1.2	7.6	2.1	6.6	ns
$t_{PLZ}$			1.7	3.7	5.2	1	7.9	1.7	5.7	

PARAMETER MEASUREMENT INFORMATION

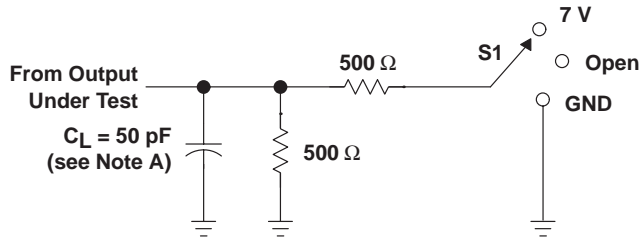

TEST	S1
$t_{PLH}/t_{PHL}$	Open
$t_{PLZ}/t_{PZL}$	7 V
$t_{PHZ}/t_{PZH}$	Open

LOAD CIRCUIT FOR OUTPUTS

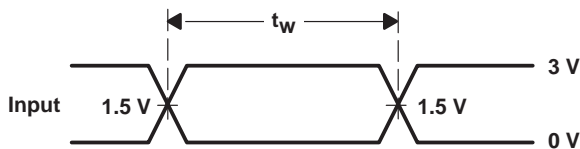

VOLTAGE WAVEFORMS  
PULSE DURATION

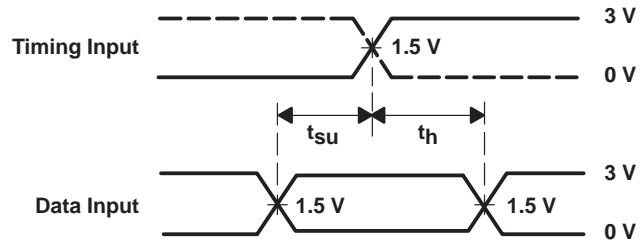

VOLTAGE WAVEFORMS  
SETUP AND HOLD TIMES

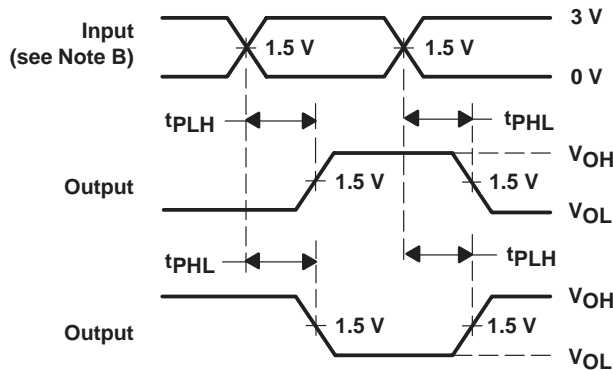

VOLTAGE WAVEFORMS  
PROPAGATION DELAY TIMES  
INVERTING AND NONINVERTING OUTPUTS

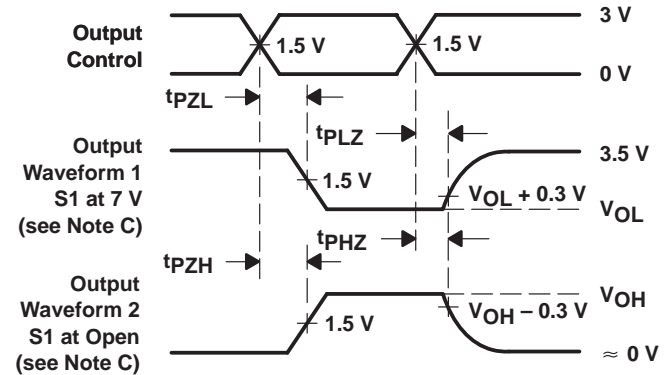

VOLTAGE WAVEFORMS  
ENABLE AND DISABLE TIMES  
LOW- AND HIGH-LEVEL ENABLING

- NOTES: A.  $C_L$  includes probe and jig capacitance.  
 B. All input pulses are supplied by generators having the following characteristics:  $PRR \leq 10$  MHz,  $Z_O = 50 \Omega$ ,  $t_r \leq 2.5$  ns,  $t_f \leq 2.5$  ns.  
 C. Waveform 1 is for an output with internal conditions such that the output is low except when disabled by the output control. Waveform 2 is for an output with internal conditions such that the output is high except when disabled by the output control.  
 D. The outputs are measured one at a time with one transition per measurement.

Figure 1. Load Circuit and Voltage Waveforms



## IMPORTANT NOTICE

Texas Instruments and its subsidiaries (TI) reserve the right to make changes to their products or to discontinue any product or service without notice, and advise customers to obtain the latest version of relevant information to verify, before placing orders, that information being relied on is current and complete. All products are sold subject to the terms and conditions of sale supplied at the time of order acknowledgement, including those pertaining to warranty, patent infringement, and limitation of liability.

TI warrants performance of its semiconductor products to the specifications applicable at the time of sale in accordance with TI's standard warranty. Testing and other quality control techniques are utilized to the extent TI deems necessary to support this warranty. Specific testing of all parameters of each device is not necessarily performed, except those mandated by government requirements.

CERTAIN APPLICATIONS USING SEMICONDUCTOR PRODUCTS MAY INVOLVE POTENTIAL RISKS OF DEATH, PERSONAL INJURY, OR SEVERE PROPERTY OR ENVIRONMENTAL DAMAGE ("CRITICAL APPLICATIONS"). TI SEMICONDUCTOR PRODUCTS ARE NOT DESIGNED, AUTHORIZED, OR WARRANTED TO BE SUITABLE FOR USE IN LIFE-SUPPORT DEVICES OR SYSTEMS OR OTHER CRITICAL APPLICATIONS. INCLUSION OF TI PRODUCTS IN SUCH APPLICATIONS IS UNDERSTOOD TO BE FULLY AT THE CUSTOMER'S RISK.

In order to minimize risks associated with the customer's applications, adequate design and operating safeguards must be provided by the customer to minimize inherent or procedural hazards.

TI assumes no liability for applications assistance or customer product design. TI does not warrant or represent that any license, either express or implied, is granted under any patent right, copyright, mask work right, or other intellectual property right of TI covering or relating to any combination, machine, or process in which such semiconductor products or services might be or are used. TI's publication of information regarding any third party's products or services does not constitute TI's approval, warranty or endorsement thereof.