

Features

- * 450W peak pulse power (8/20 μ s)
- * Protects one data or power line
- * Ultra low leakage: nA level
- * Operating voltage: 5V
- * Ultra low clamping voltage
- * Complies with following standards:
 - IEC 61000-4-2 (ESD) immunity test
 - Air discharge: ± 30 kV
 - Contact discharge: ± 30 kV
 - IEC61000-4-4 (Lightning) 30A (8/20ns)
- * RoHS Compliant
- * Package: SOD-323
- * Lead Finish: Matte Tin

Circuit Diagram

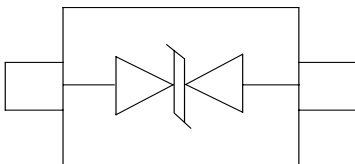

Marking Diagram

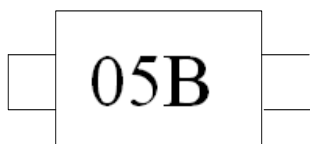

Transparent top view

05B: Device Marking Code

Description

The PESD5V0S1BA is designed to replace multilayer varistors in portable applications such as cell phones, notebook computers and PDA's, using monolithic silicon technology to provide fast response time and ultra low ESD clamping voltage, making this device an ideal solution for protecting sensitive semiconductor components from damage.

The PESD5V0S1BA complies with the IEC 61000-4-2 (ESD) standard with ± 15 kV air and ± 8 kV contact discharge. The PESD5V0S1BA is assembled into a lead-free SOD-323 package and will protect one unidi-rectional line. These devices will fit on the same PCB pad area as an 0805 MLV device.

Applications

- * Cellular Handsets and Accessories
- * Personal Digital Assistants
- * Notebooks and Handhelds
- * Portable Instrumentation
- * Peripherals
- * Pagers Peripherals
- * Desktop and Servers

Ordering Information

Part Number	Packaging	Reel Size
PESD5V0S1BA	3000/Tape & Reel	7 inch

Absolute Maximum Ratings ($T_A=25^\circ\text{C}$ unless otherwise specified)

Parameter	Symbol	Value	Unit
Peak Pulse Power (8/20 μs)	Ppk	450	W
Peak Pulse Current (8/20 μs)	IPP	30	A
ESD per IEC 61000-4-2 (Air)	VESD	± 30	kV
ESD per IEC 61000-4-2 (Contact)		± 30	
Operating Temperature Range	TJ	-55 to +125	$^\circ\text{C}$
Storage Temperature Range	Tstg	-55 to +150	$^\circ\text{C}$

Electrical Characteristics ($T_A=25^\circ\text{C}$ unless otherwise specified)

Parameter	Symbol	Test Condition	Min	Typ	Max	Unit
Reverse Working Voltage	V_{RWM}				5	V
Breakdown Voltage	V_{BR}	$I_T = 1\text{mA}(\text{Pin1-Pin2})$	6.0	7.0	8.0	V
Reverse Leakage Current	I_R	$V_{RWM} = 5.0\text{V}(\text{Pin2-Pin1})$			0.5	μA
Clamping Voltage	V_C	$I_{PP} = 10\text{A} (8 \times 20\mu\text{s pulse})$ (Pin1-Pin2)		9.0	11.0	V
Clamping Voltage	V_C	$I_{PP} = 30\text{A} (8 \times 20\mu\text{s pulse})$ (Pin1-Pin2)		12.0	15.0	V
Junction Capacitance	C_J	$V_R = 0\text{V}, f = 1\text{MHz}$ (Pin1-Pin2)		60	100	pF

Portion Electronics Parameter

Symbol	Parameter
I_T	Test Current
I_{PP}	Maximum Reverse Peak Pulse Current
V_C	Clamping Voltage @ I_C

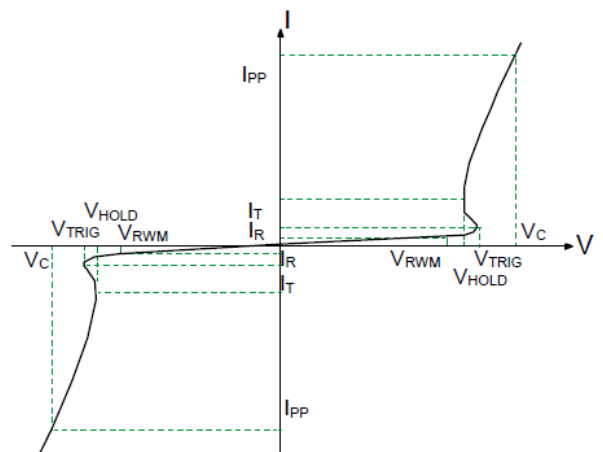



Typical Performance Characteristics ($T_A=25^\circ\text{C}$ unless otherwise Specified)

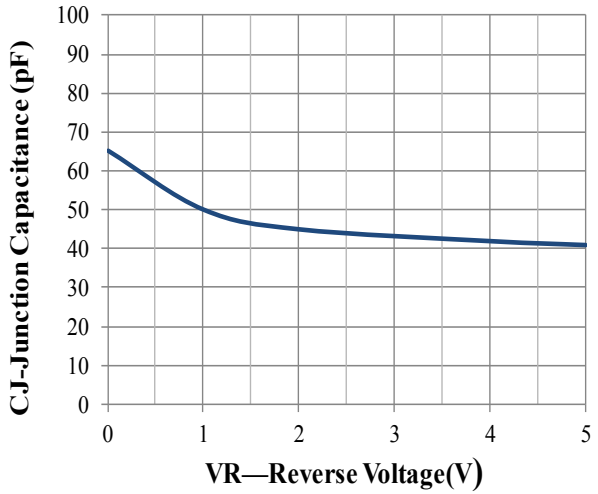

Junction Capacitance vs. Reverse Voltage

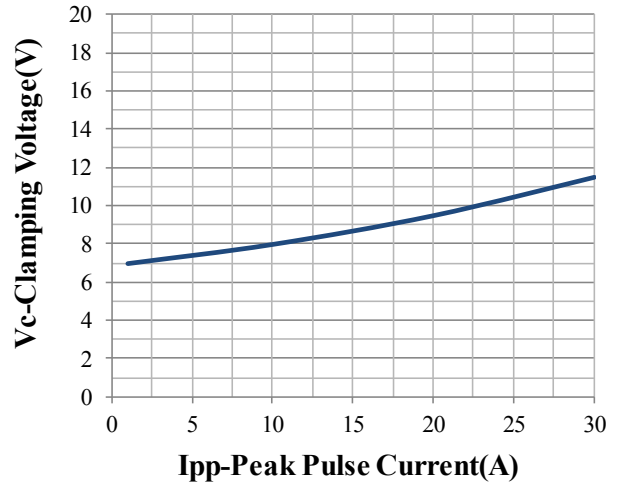

Clamping Voltage vs. Peak Pulse Current

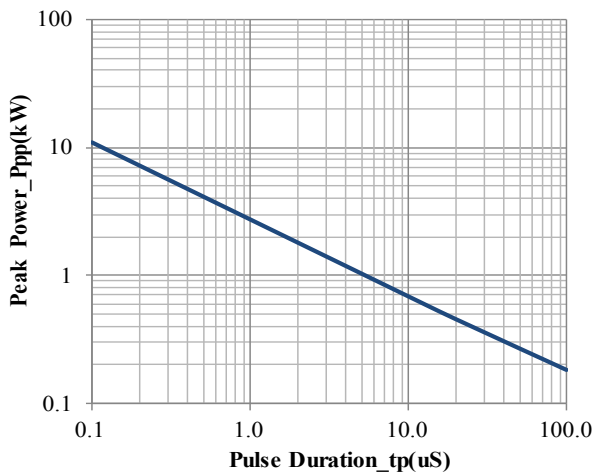

Peak Pulse Power vs. Pulse Time

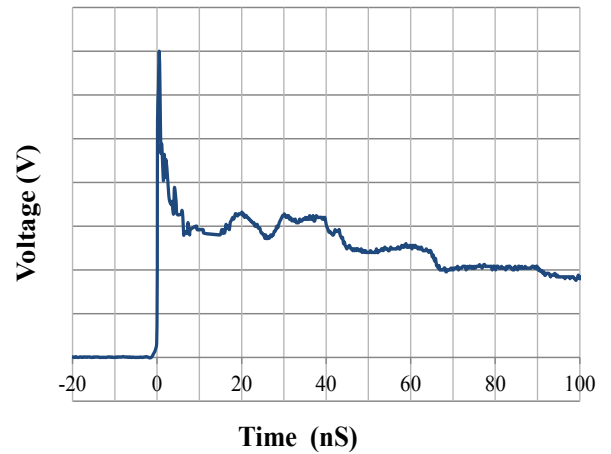

IEC61000-4-2 Pulse Waveform

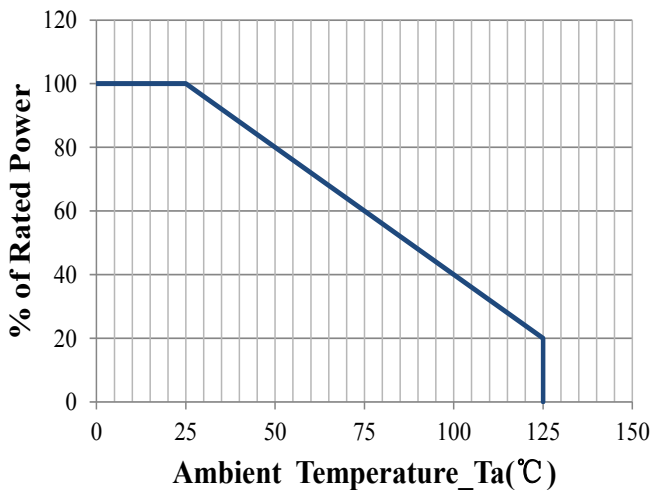

Power Derating Curve

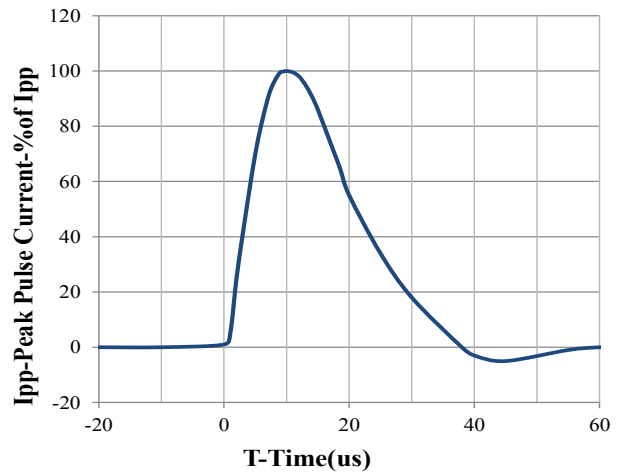

8 X 20us Pulse Waveform



SOD-323 Package Outline Drawing

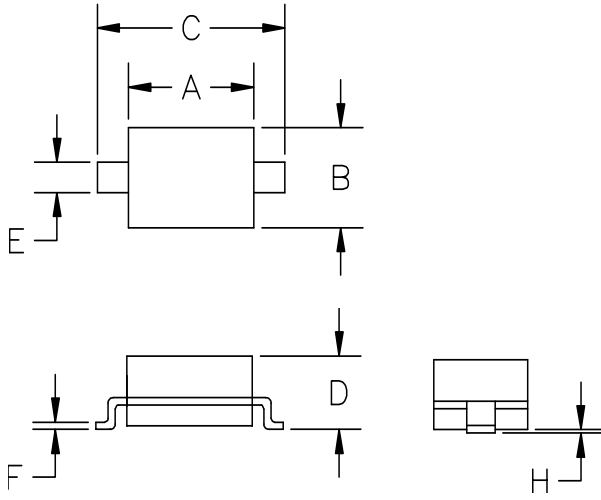

SYM	DIMENSIONS			
	MILLIMETERS		INCHES	
	MIN	MAX	MIN	MAX
A	1.50	1.80	0.060	0.071
B	1.20	1.40	0.045	0.054
C	2.30	2.70	0.090	0.107
D	-	1.10	-	0.043
E	0.30	0.40	0.012	0.016
F	0.10	0.25	0.004	0.010
H	-	0.10	-	0.004

Suggested Land Pattern

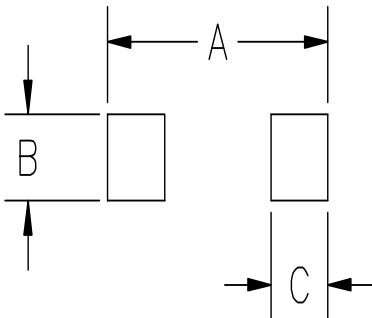

SYM	DIMENSIONS	
	MILLIMETERS	INCHES
A	3.15	0.120
B	0.80	0.031
C	0.80	0.031