

TL331 SINGLE DIFFERENTIAL COMPARATOR

SLVS238A – AUGUST 1999 – REVISED NOVEMBER 1999

- Single Supply or Dual Supplies
- Wide Range of Supply Voltage . . . 2 V to 36 V
- Low Supply-Current Drain Independent of Supply Voltage . . . 0.4 mA Typ
- Low Input Bias Current . . . 25 nA Typ
- Low Input Offset Voltage . . . 2 mV Typ
- Common-Mode Input Voltage Range Includes Ground
- Differential Input Voltage Range Equal to Maximum-Rated Supply Voltage . . . ± 36 V
- Low Output Saturation Voltage
- Output Compatible With TTL, MOS, and CMOS
- Packaged in Plastic Small-Outline Transistor Package

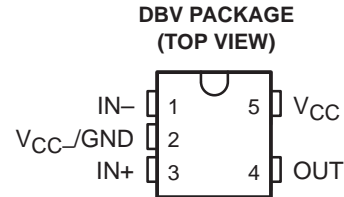

description

This device consists of a single voltage comparator that is designed to operate from a single power supply over a wide range of voltages. Operation from dual supplies also is possible if the difference between the two supplies is 2 V to 36 V and V_{CC} is at least 1.5 V more positive than the input common-mode voltage. Current drain is independent of the supply voltage. The output can be connected to other open-collector outputs to achieve wired-AND relationships.

The TL331I is characterized for operation from -40°C to 85°C .

logic diagram



AVAILABLE OPTIONS

T_A	$V_{IO(max)}$ AT 25°C	PACKAGED DEVICE
		SMALL-OUTLINE TRANSISTOR (DBV)
-40°C to 85°C	5 mV	TL331IDBV

The DBV package is only available left-end taped and reeled. Add suffix R to device type (e.g., TL331IDBVR).



Please be aware that an important notice concerning availability, standard warranty, and use in critical applications of Texas Instruments semiconductor products and disclaimers thereto appears at the end of this data sheet.

PRODUCTION DATA information is current as of publication date. Products conform to specifications per the terms of Texas Instruments standard warranty. Production processing does not necessarily include testing of all parameters.

 **TEXAS
INSTRUMENTS**

POST OFFICE BOX 655303 • DALLAS, TEXAS 75265

Copyright © 1999, Texas Instruments Incorporated

TL331 SINGLE DIFFERENTIAL COMPARATOR

SLVS238A – AUGUST 1999 – REVISED NOVEMBER 1999

schematic

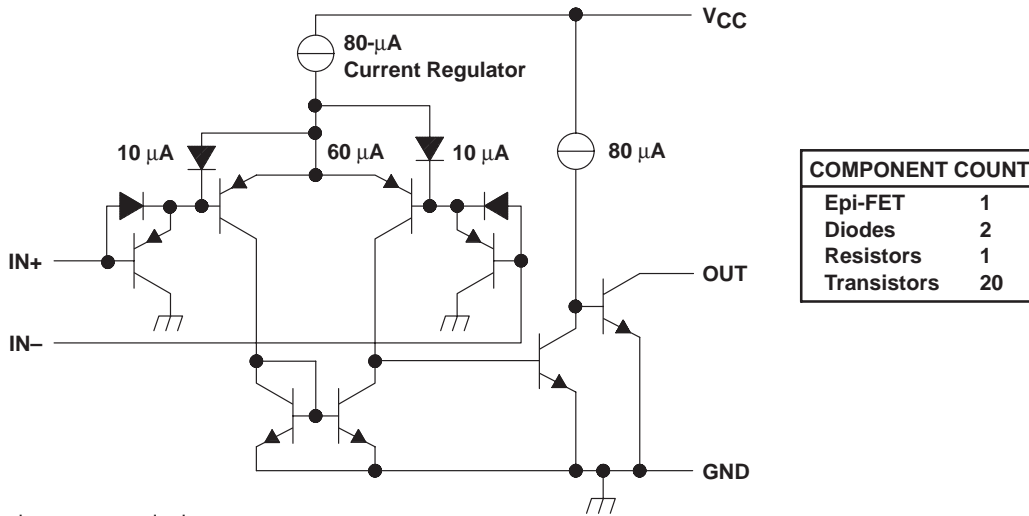

Current values shown are nominal.

absolute maximum ratings over operating free-air temperature range (unless otherwise noted)†

Supply voltage, V_{CC} (see Note 1)	36 V
Differential input voltage, V_{ID} (see Note 2)	± 36 V
Input voltage range, V_I (either input)	-0.3 V to 36 V
Output voltage, V_O	36 V
Output current, I_O	20 mA
Duration of output short-circuit to ground (see Note 3)	Unlimited
Package thermal impedance, θ_{JA} (see Notes 4 and 5)	347°C/W
Operating free-air temperature range, T_A	-40°C to 85°C
Lead temperature 1,6 mm (1/16 inch) from case for 10 seconds	260°C
Storage temperature range, T_{stg}	-65°C to 150°C

† Stresses beyond those listed under “absolute maximum ratings” may cause permanent damage to the device. These are stress ratings only, and functional operation of the device at these or any other conditions beyond those indicated under “recommended operating conditions” is not implied. Exposure to absolute-maximum-rated conditions for extended periods may affect device reliability.

- NOTES:
- All voltage values, except differential voltages, are with respect to the network ground.
 - Differential voltages are at IN+ with respect to IN-.
 - Short circuits from outputs to V_{CC} can cause excessive heating and eventual destruction.
 - Maximum power dissipation is a function of $T_J(\max)$, θ_{JA} , and T_A . The maximum allowable power dissipation at any allowable ambient temperature is $P_D = (T_J(\max) - T_A)/\theta_{JA}$. Operating at the absolute maximum T_J of 150°C can impact reliability.
 - The package thermal impedance is calculated in accordance with JESD 51.

TL331 SINGLE DIFFERENTIAL COMPARATOR

SLVS238A – AUGUST 1999 – REVISED NOVEMBER 1999

electrical characteristics at specified free-air temperature, $V_{CC} = 5\text{ V}$ (unless otherwise noted)

PARAMETER		TEST CONDITIONS	T_A †	MIN	TYP	MAX	UNIT
V_{IO}	Input offset voltage	$V_{CC} = 5\text{ V to }30\text{ V}$, $V_O = 1.4\text{ V}$, $V_{IC} = V_{IC(min)}$	25°C		2	5	mV
			-40°C to 85°C			9	
I_{IO}	Input offset current	$V_O = 1.4\text{ V}$	25°C		5	50	nA
			-40°C to 85°C			250	
I_{IB}	Input bias current	$V_O = 1.4\text{ V}$	25°C		-25	-250	nA
			-40°C to 85°C			-400	
V_{ICR}	Common-mode input voltage range‡		25°C		0 to $V_{CC}-1.5$		V
			-40°C to 85°C		0 to $V_{CC}-2$		
A_{VD}	Large-signal differential voltage amplification	$V_{CC} = 15\text{ V}$, $V_O = 1.4\text{ V to }11.4\text{ V}$, $R_L \geq 15\text{ k}\Omega$ to V_{CC}	25°C		50	200	V/mV
I_{OH}	High-level output current	$V_{OH} = 5\text{ V}$, $V_{ID} = 1\text{ V}$ $V_{OH} = 30\text{ V}$, $V_{ID} = 1\text{ V}$	25°C		0.1	50	nA
			-40°C to 85°C			1	μA
V_{OL}	Low-level output voltage	$I_{OL} = 4\text{ mA}$, $V_{ID} = -1\text{ V}$	25°C		150	400	mV
			-40°C to 85°C			700	
I_{OL}	Low-level output current	$V_{OL} = 1.5\text{ V}$, $V_{ID} = 1\text{ V}$	25°C		6		mA
I_{CC}	Supply current	$R_L = \infty$, $V_{CC} = 5\text{ V}$	25°C		0.4	0.7	mA

† All characteristics are measured with zero common-mode input voltage, unless otherwise specified.

‡ The voltage at either input or common-mode should not be allowed to go negative by more than 0.3 V. The upper end of the common-mode voltage range is $V_{CC+} - 1.5\text{ V}$, but either or both inputs can go to 30 V without damage.

switching characteristics, $V_{CC} = 5\text{ V}$, $T_A = 25^\circ\text{C}$

PARAMETER	TEST CONDITIONS		MIN	TYP	MAX	UNIT
Response time	R_L connected to 5 V through 5.1 k Ω , $C_L = 15\text{ pF}$ §, See Note 6	100-mV input step with 5-mV overdrive		1.3		μs
		TTL-level input step		0.3		

§ C_L includes probe and jig capacitance.

NOTE 6: The response time specified is the interval between the input step function and the instant when the output crosses 1.4 V.

IMPORTANT NOTICE

Texas Instruments and its subsidiaries (TI) reserve the right to make changes to their products or to discontinue any product or service without notice, and advise customers to obtain the latest version of relevant information to verify, before placing orders, that information being relied on is current and complete. All products are sold subject to the terms and conditions of sale supplied at the time of order acknowledgement, including those pertaining to warranty, patent infringement, and limitation of liability.

TI warrants performance of its semiconductor products to the specifications applicable at the time of sale in accordance with TI's standard warranty. Testing and other quality control techniques are utilized to the extent TI deems necessary to support this warranty. Specific testing of all parameters of each device is not necessarily performed, except those mandated by government requirements.

CERTAIN APPLICATIONS USING SEMICONDUCTOR PRODUCTS MAY INVOLVE POTENTIAL RISKS OF DEATH, PERSONAL INJURY, OR SEVERE PROPERTY OR ENVIRONMENTAL DAMAGE ("CRITICAL APPLICATIONS"). TI SEMICONDUCTOR PRODUCTS ARE NOT DESIGNED, AUTHORIZED, OR WARRANTED TO BE SUITABLE FOR USE IN LIFE-SUPPORT DEVICES OR SYSTEMS OR OTHER CRITICAL APPLICATIONS. INCLUSION OF TI PRODUCTS IN SUCH APPLICATIONS IS UNDERSTOOD TO BE FULLY AT THE CUSTOMER'S RISK.

In order to minimize risks associated with the customer's applications, adequate design and operating safeguards must be provided by the customer to minimize inherent or procedural hazards.

TI assumes no liability for applications assistance or customer product design. TI does not warrant or represent that any license, either express or implied, is granted under any patent right, copyright, mask work right, or other intellectual property right of TI covering or relating to any combination, machine, or process in which such semiconductor products or services might be or are used. TI's publication of information regarding any third party's products or services does not constitute TI's approval, warranty or endorsement thereof.



PRODUCT FOLDER | PRODUCT INFO: [FEATURES](#) | [DESCRIPTION](#) | [DATASHEETS](#) | [PRICING/AVAILABILITY/PKG](#) | [SAMPLES](#)
 | [APPLICATION NOTES](#) | [RELATED DOCUMENTS](#)

TL331, Single Differential Comparator

DEVICE STATUS: ACTIVE

PARAMETER NAME	TL331
IQ per channel (max) (mA)	0.7
Output Current (min) (mA)	6
tRESP Low - to - High (us)	0.3
Vs (max) (V)	36
Vs (min) (V)	2
VICR (min) (V)	8
VIO (25 deg C) (max) (mV)	5
Rail-Rail	No
Output Type	Open Drain/Collector
Number of Channels	1

FEATURES

[▲Back to Top](#)

- Single Supply or Dual Supplies
- Wide Range of Supply Voltage
...2 V to 36 V
- Low Supply-Current Drain Independent of Supply Voltage...0.4 mA Typ
- Low Input Bias Current...25 nA Typ
- Low Input Offset Voltage...2 mV Typ
- Common-Mode Input Voltage Range Includes Ground
- Differential Input Voltage Range Equal to Maximum-Rated Supply Voltage...±36 V
- Low Output Saturation Voltage
- Output Compatible With TTL, MOS, and CMOS
- Packaged in Plastic Small-Outline Transistor Package

DESCRIPTION

[▲Back to Top](#)

This device consists of a single voltage comparator that is designed to operate from a single power supply over a wide range of voltages. Operation from dual supplies also is possible if the difference between the two supplies is 2 V to 36 V and V_{CC} is at least 1.5 V more positive than the input common-mode voltage. Current drain is independent of the supply voltage. The output can be connected to other open-collector outputs to achieve wired-AND relationships.

The TL331I is characterized for operation from -40°C to 85°C.

TECHNICAL RESOURCES

[▲Back to Top](#)

To view the following documents, [Acrobat Reader 4.0](#) is required.

To download a document to your hard drive, right-click on the link and choose 'Save'.

DATASHEET

[▲Back to Top](#)

Full datasheet in Acrobat PDF: [tl331.pdf](#) (60 KB,Rev.A) (Updated: 11/22/1999)

- [AB-172: Current Feedback Amplifiers: Review, Stability Analysis, and Applications](#) (SBOA081 - Updated: 11/20/2000)
- [Analysis of the Sallen-Key Architecture \(Rev. A\)](#) (SLOA024A - Updated: 07/27/1999)

RELATED DOCUMENTS

[▲ Back to Top](#)

- [Military Analog Selection Guide](#) (SGLB002, 318 KB - Updated: 11/09/2000)
- [Military Semiconductors Selection Guide 2002 \(Rev. B\)](#) (SGYC003B, 1648 KB - Updated: 04/22/2002)

SAMPLES

[▲ Back to Top](#)

ORDERABLE DEVICE	PACKAGE	PINS	TEMP (°C)	STATUS	SAMPLES
TL331IDBVR	DBV	5	-40 TO 85	ACTIVE	Request Samples

PRICING/AVAILABILITY/PKG

[▲ Back to Top](#)

ORDERABLE DEVICE	PACKAGE	PINS	TEMP (°C)	STATUS	BUDGETARY PRICE US\$/UNIT QTY= 1000+	PACK QTY	PRICING/AVAILABILITY/PKG
TL331CD	D	8		OBSOLETE			
TL331IDBVR	DBV	5	-40 TO 85	ACTIVE	0.28	3000	Check stock or order
TL331IDR	D	8		OBSOLETE			
TL331IP	P	8		OBSOLETE			

Table Data Updated on: 7/25/2002

[Products](#) | [Applications](#) | [Support](#) | [TI&ME](#)

 TEXAS INSTRUMENTS © Copyright 1995-2002 Texas Instruments Incorporated. All rights reserved.

[Trademarks](#) | [Privacy Policy](#) | [Terms of Use](#)