

# CR02AM-8

400V - 0.2A - Thyristor

Low Power Use

R07DS1423EJ0400

Rev.4.00

Feb. 22, 2022

## Features

- $I_T(AV)$ : 0.3 A
- $V_{DRM}$ : 400 V
- $I_{GT}$ : 100  $\mu$ A
- RoHS Compliant
- Planar Passivation Type
- Halogen-free (PRSS0003DJ-A)
- Completely Pb-free (PRSS0003DJ-A)

## Outline

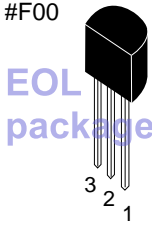
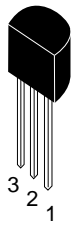
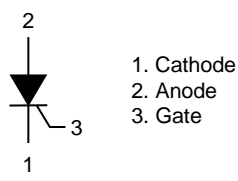
RENESAS Package code: PRSS0003EA-A (Package name: TO-92*)	PRSS0003DJ-A (Package name: TO-92)	
Ordering code: #F00	#BD0	
		

## Application

Solid state relay, leakage protector, timer, electric blanket, strobe flasher, and other general purpose applications.

## Maximum Ratings

Parameter	Symbol	Voltage class		Unit
		8		
Repetitive peak reverse voltage	$V_{RRM}$	400		V
Non-repetitive peak reverse voltage	$V_{RSM}$	500		V
Repetitive peak off-state voltage <sup>Note1</sup>	$V_{DRM}$	400		V

Notes: 1. With gate to cathode resistance  $R_{GK}=1$  k $\Omega$

Parameter	Symbol	Ratings	Unit	Conditions
RMS on-state current	$I_T(RMS)$	0.47	A	
Average on-state current	$I_T(AV)$	0.3	A	Commercial frequency, sine half wave 180°conduction, $T_a = 30^\circ\text{C}$
Surge on-state current	$I_{TSM}$	10	A	60 Hz sinewave 1 full cycle, peak value, non-repetitive
$I^2t$ for fusing	$I^2t$	0.4	A <sup>2</sup> s	Value corresponding to 1 cycle of half wave 60 Hz, surge on-state current
Peak gate power dissipation	$P_{GM}$	0.1	W	
Average gate power dissipation	$P_{G(AV)}$	0.01	W	
Peak gate forward voltage	$V_{FGM}$	6	V	
Peak gate reverse voltage	$V_{RGM}$	6	V	
Peak gate forward current	$I_{FGM}$	0.1	A	
Junction temperature	$T_j$	-40 to +125	°C	
Storage temperature	$T_{stg}$	-40 to +125	°C	

## Electrical Characteristics

Parameter	Symbol	Min.	Typ.	Max.	Unit	Test conditions
Repetitive peak reverse current	$I_{RRM}$	—	—	0.1	mA	$T_j = 125^\circ\text{C}$ , $V_{RRM}$ applied
Repetitive peak off-state current	$I_{DRM}$	—	—	0.1	mA	$T_j = 125^\circ\text{C}$ , $V_{DRM}$ applied $R_{GK}=1\text{ k}\Omega$
On-state voltage	$V_{TM}$	—	—	1.6	V	$T_c = 25^\circ\text{C}$ , $I_{TM} = 0.6\text{ A}$ , instantaneous value
Gate trigger voltage	$V_{GT}$	—	—	0.8	V	$T_j = 25^\circ\text{C}$ , $V_D = 6\text{ V}$ , $I_T = 0.1\text{ A}$ <sup>Note3</sup>
Gate non-trigger voltage	$V_{GD}$	0.2	—	—	V	$T_j = 125^\circ\text{C}$ , $V_D = 1/2 V_{DRM}$ $R_{GK}=1\text{ k}\Omega$
Gate trigger current	$I_{GT}$	1	—	100 <sup>Note2</sup>	$\mu\text{A}$	$T_j = 25^\circ\text{C}$ , $V_D = 6\text{ V}$ , $I_T = 0.1\text{ A}$ <sup>Note3</sup>
Holding current	$I_H$	—	—	3	mA	$T_j = 25^\circ\text{C}$ , $V_D = 12\text{ V}$ , $R_{GK}=1\text{ k}\Omega$
Thermal resistance	$R_{th(j-a)}$	—	—	180	$^\circ\text{C/W}$	Junction to ambient

Notes: 2. If special values of  $I_{GT}$  are required, choose item D or E from those listed in the table below if possible.

Item	A	B	C	D	E
$I_{GT}$ ( $\mu\text{A}$ )	1 to 30	20 to 50	40 to 100	1 to 50	20 to 100

The above values do not include the current flowing through the  $1\text{ k}\Omega$  resistance between the gate and cathode.

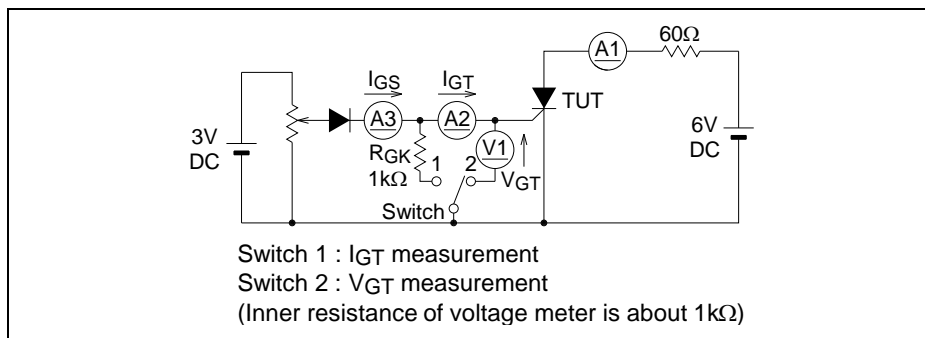
3.  $I_{GT}$ ,  $V_{GT}$  measurement circuit.

Performance Curves

Maximum On-State Characteristics

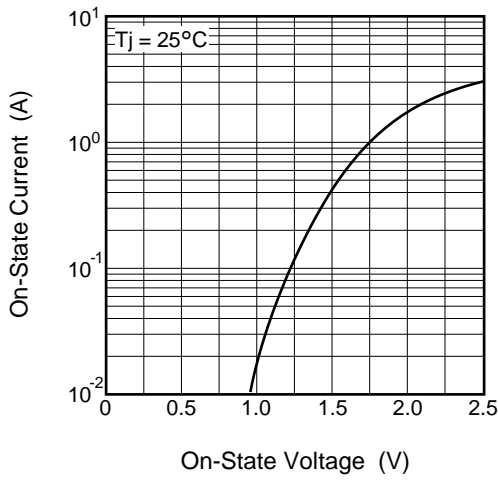

Rated Surge On-State Current

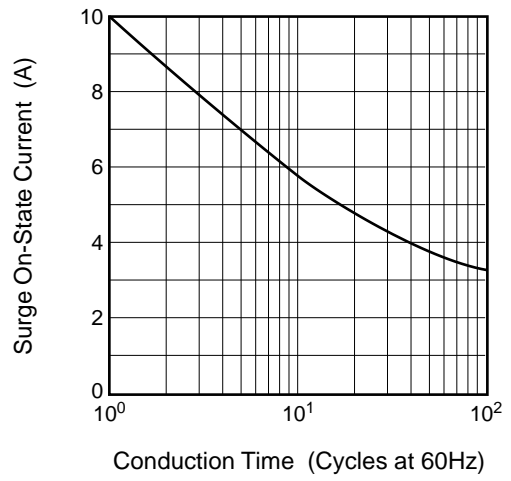

Gate Characteristics

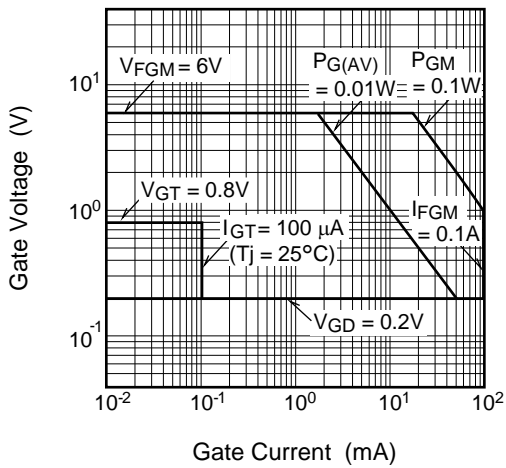

Gate Trigger Current vs. Junction Temperature

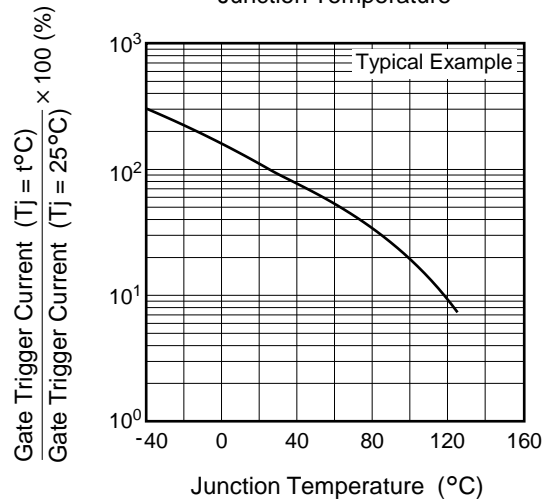

Gate Trigger Voltage vs. Junction Temperature

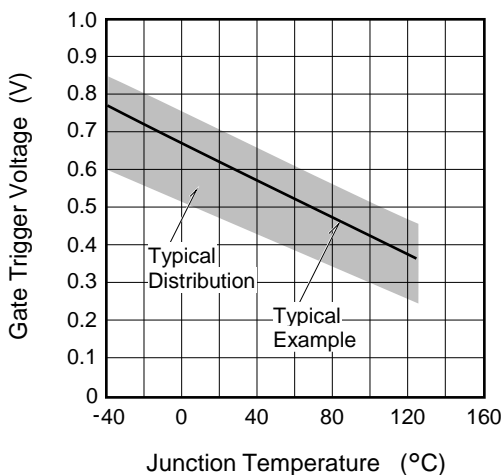

Maximum Transient Thermal Impedance Characteristics (Junction to ambient)

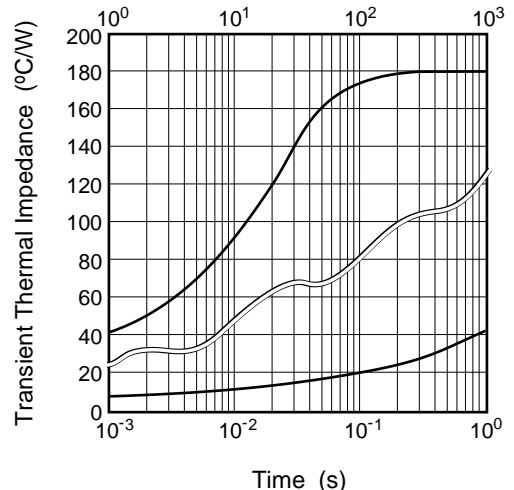

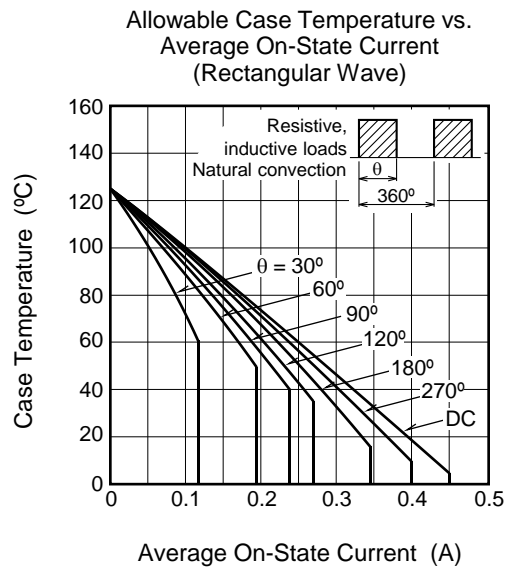
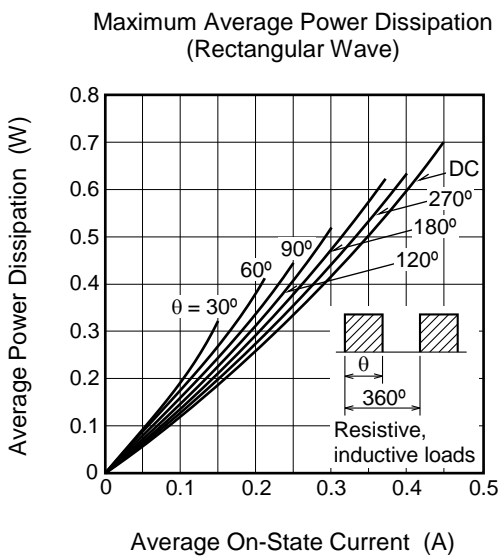
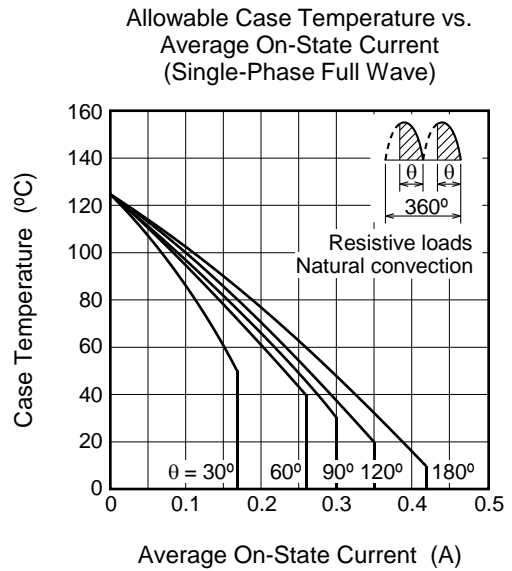
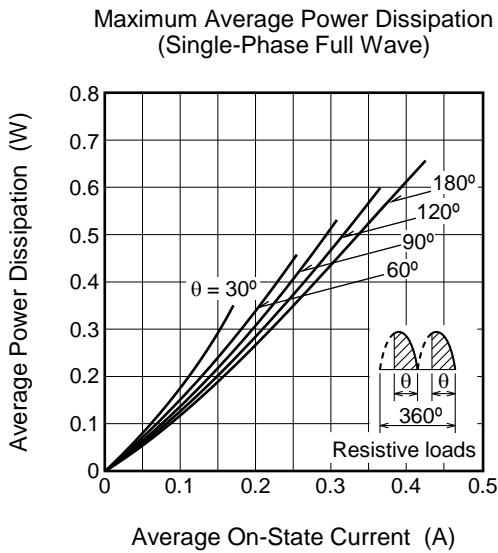
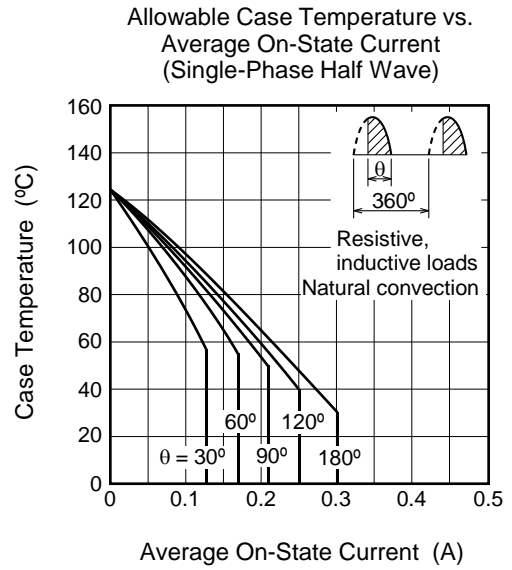
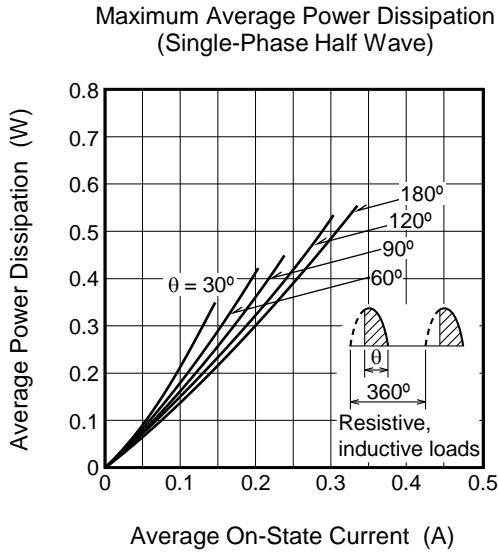

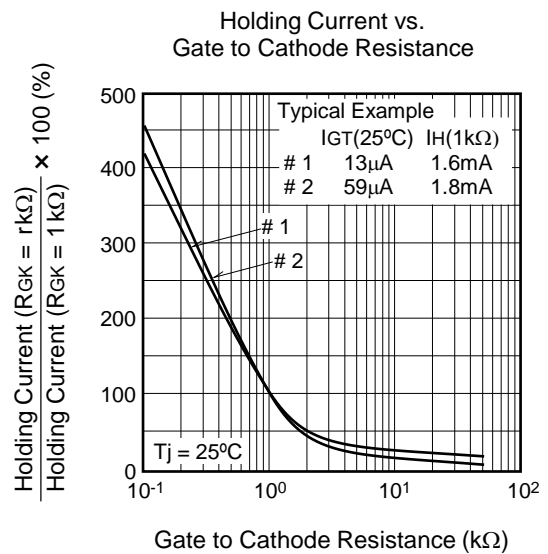
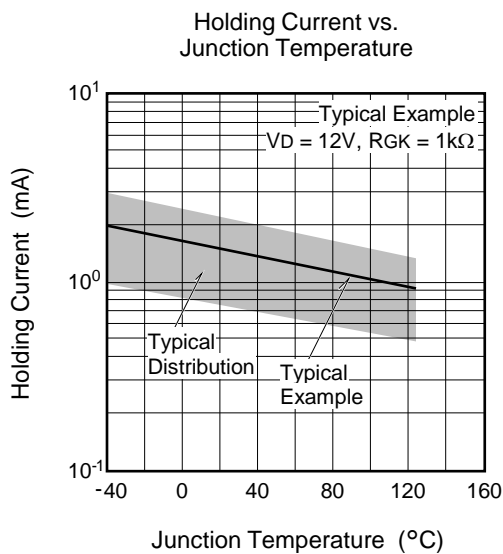
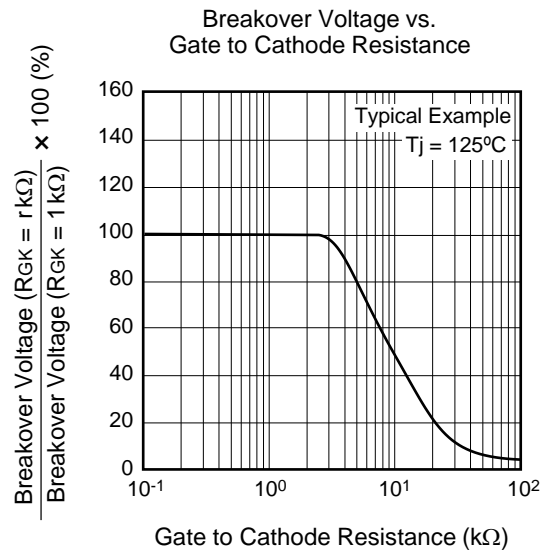
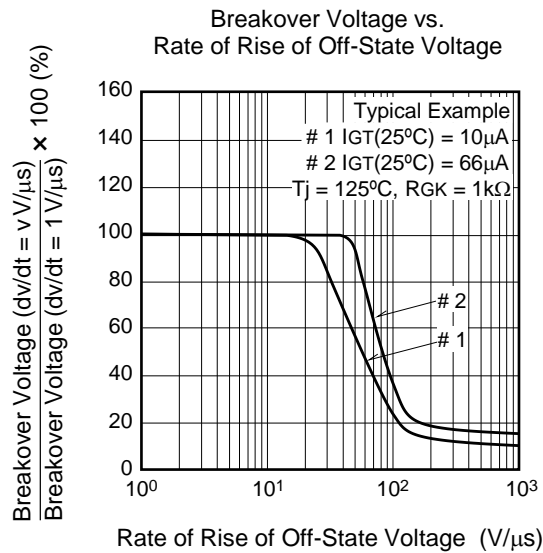
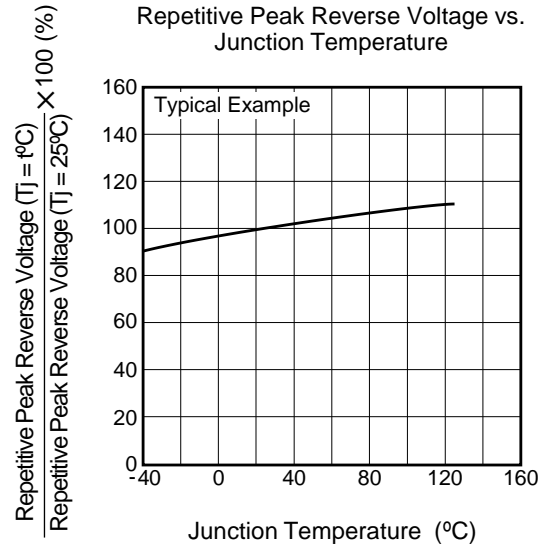
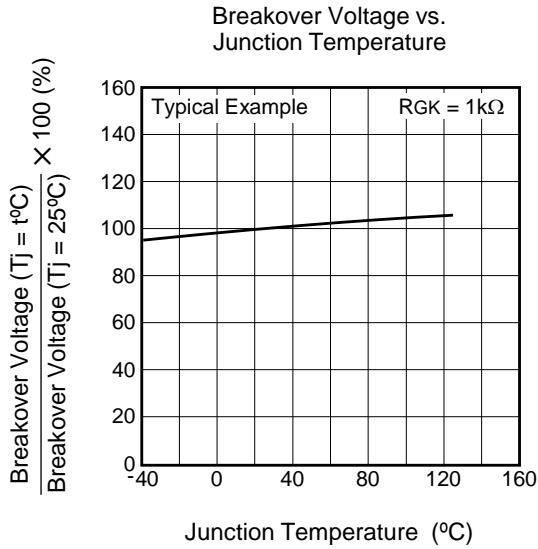

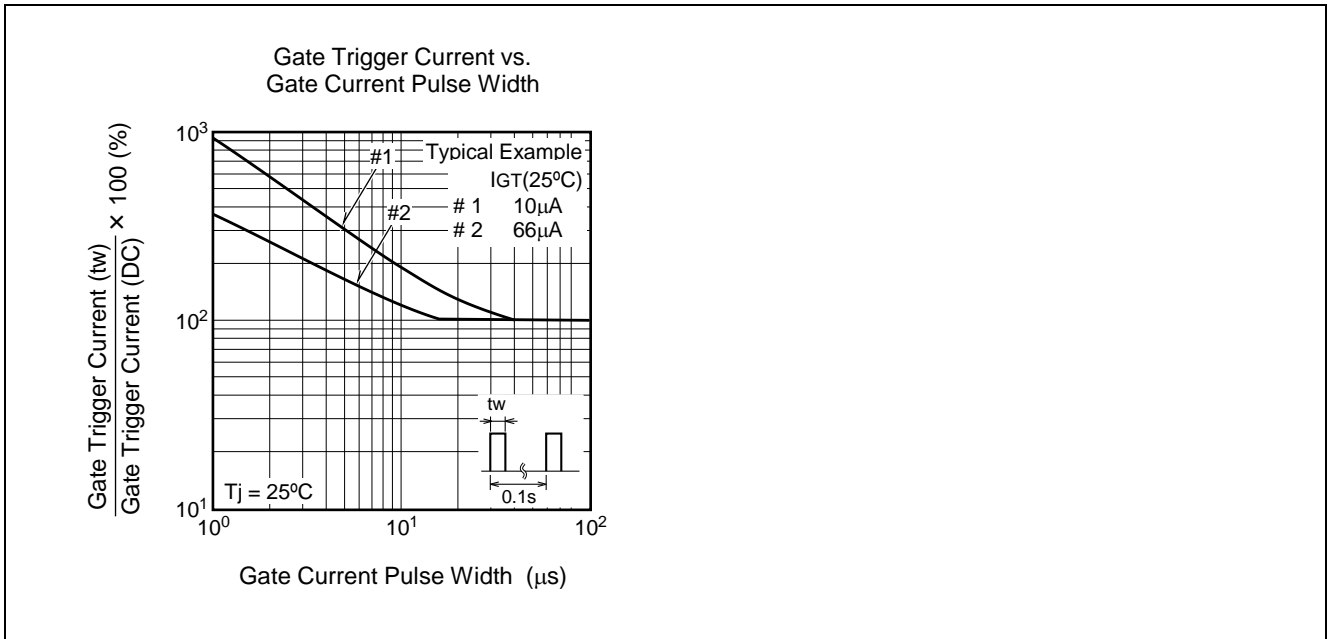

### Package Dimensions

Ordering code: #BD0 <Active>

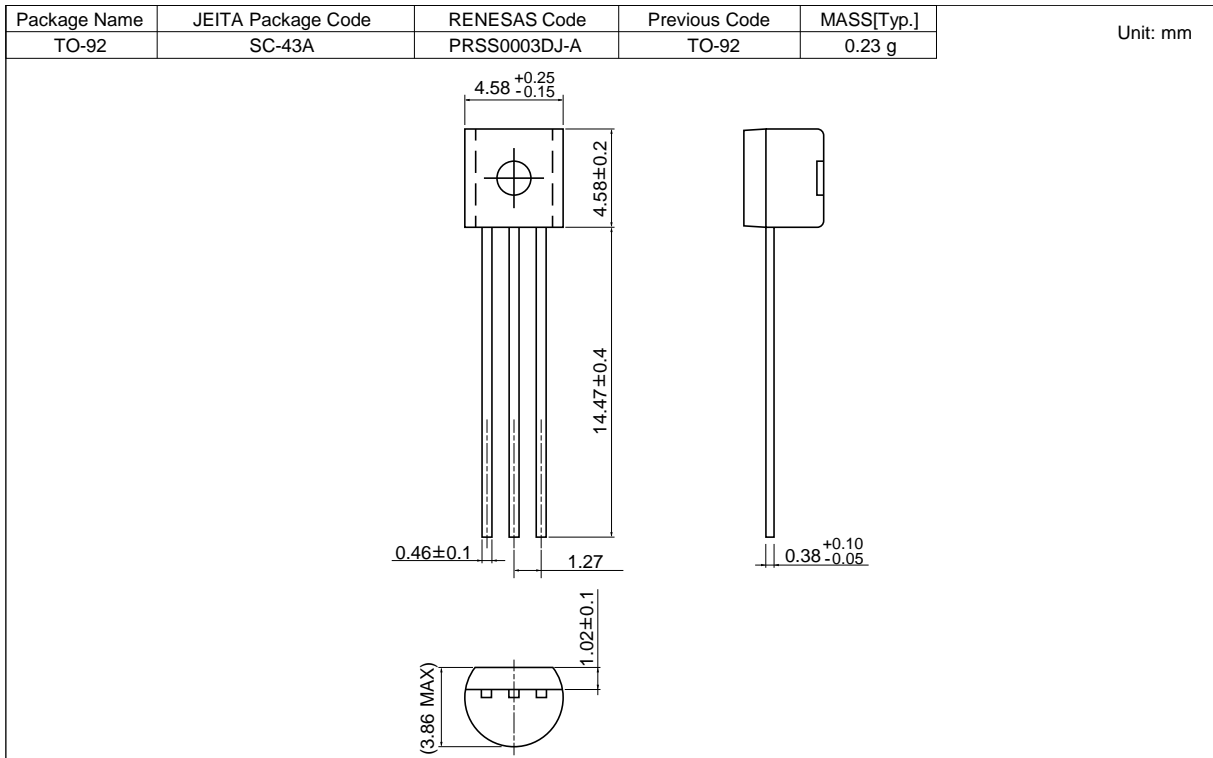

Ordering code: #F00 <Obsolete>

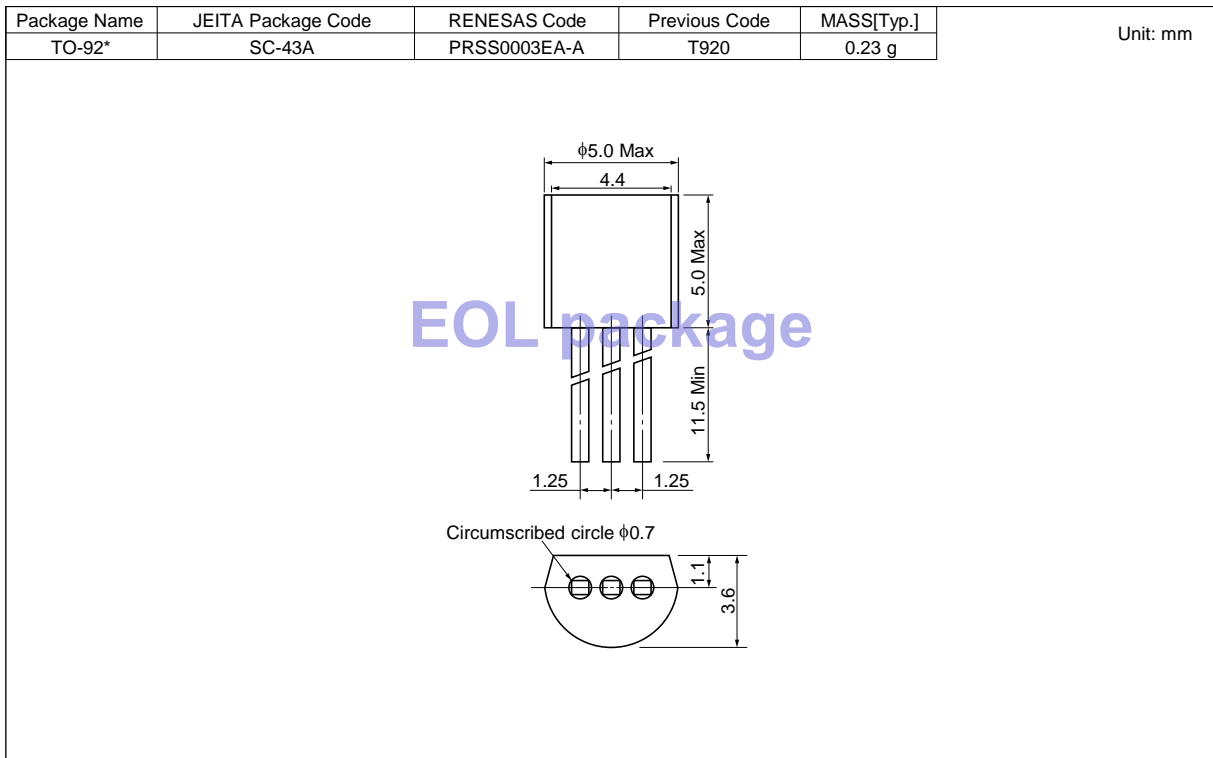

## Ordering Information

Orderable Part Number	Package	Packing <sup>Note4</sup>	Quantity	Remark	Status
CR02AM-8#BD0	TO-92	Plastic Bag	1000 pcs.	Straight type	Active
CR02AM-8-□#BD0	TO-92	Plastic Bag	1000 pcs.	Straight type, □:IGT item	
CR02AM-8-A6#BD0	TO-92	Plastic Bag	1000 pcs.	A6 Lead form	
CR02AM-8-□A6#BD0	TO-92	Plastic Bag	1000 pcs.	A6 Lead form, □:IGT item	
CR02AM-8-TB#BD0	TO-92	Adhesive Tape	2000 pcs.	A8 Lead form	
CR02AM-8-□TB#BD0	TO-92	Adhesive Tape	2000 pcs.	A8 Lead form, □:IGT item	
CR02AM-8#F00	TO-92*	Plastic Bag	500 pcs.	Straight type	Obsolete
CR02AM-8-□#F00	TO-92*	Plastic Bag	500 pcs.	Straight type, □:IGT item	
CR02AM-8-A6#F00	TO-92*	Plastic Bag	500 pcs.	A6 Lead form	
CR02AM-8-□A6#F00	TO-92*	Plastic Bag	500 pcs.	A6 Lead form, □:IGT item	
CR02AM-8-TB#F00	TO-92*	Adhesive Tape	2000 pcs.	A8 Lead form	
CR02AM-8-□TB#F00	TO-92*	Adhesive Tape	2000 pcs.	A8 Lead form, □:IGT item	

Note: 4. Please confirm the specification about the shipping in detail.