

CD4512BC 8-Channel Buffered Data Selector

General Description

The CD4512BC buffered 8-channel data selector is a complementary MOS (CMOS) circuit constructed with N- and P-channel enhancement mode transistors. This data selector is primarily used as a digital signal multiplexer selecting 1 of 8 inputs and routing the signal to a 3-STATE output. A high level at the Inhibit input forces a low level at the output. A high level at the Output Enable (OE) input forces the output into the 3-STATE condition. Low levels at both the Inhibit and (OE) inputs allow normal operation.

Features

- Wide supply voltage range: 3.0V to 15V
- High noise immunity: $0.45 V_{DD}$ (typ.)
- 3-STATE output
- Low quiescent power dissipation:
0.25 μ W/package (typ.) @ $V_{CC} = 5.0V$
- Plug-in replacement for Motorola MC14512

Ordering Code:

Order Number	Package Number	Package Description
CD4512BCM	M16A	16-Lead Small Outline Integrated Circuit (SOIC), JEDEC MS-012, 0.150" Narrow Body
CD4512BCN	N16E	16-Lead Plastic Dual-In-Line Package (PDIP), JEDEC MS-001, 0.300" Wide

Devices also available in Tape and Reel. Specify by appending suffix "X" to the ordering code.

Connection Diagram

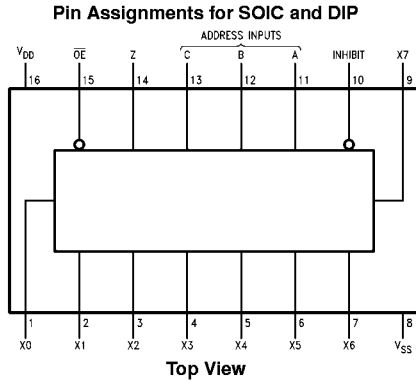

Truth Table

Address Inputs			Control Inputs		Output
C	B	A	Inhibit	OE	Z
0	0	0	0	0	X0
0	0	1	0	0	X1
0	1	0	0	0	X2
0	1	1	0	0	X3
1	0	0	0	0	X4
1	0	1	0	0	X5
1	1	0	0	0	X6
1	1	1	0	0	X7
2	1	1	1	0	0
2	2	2	2	1	Hi-Z

2 = Don't care
Hi-Z = 3-STATE condition
Xn = Data at input n

CD4512BC

Logic Diagram

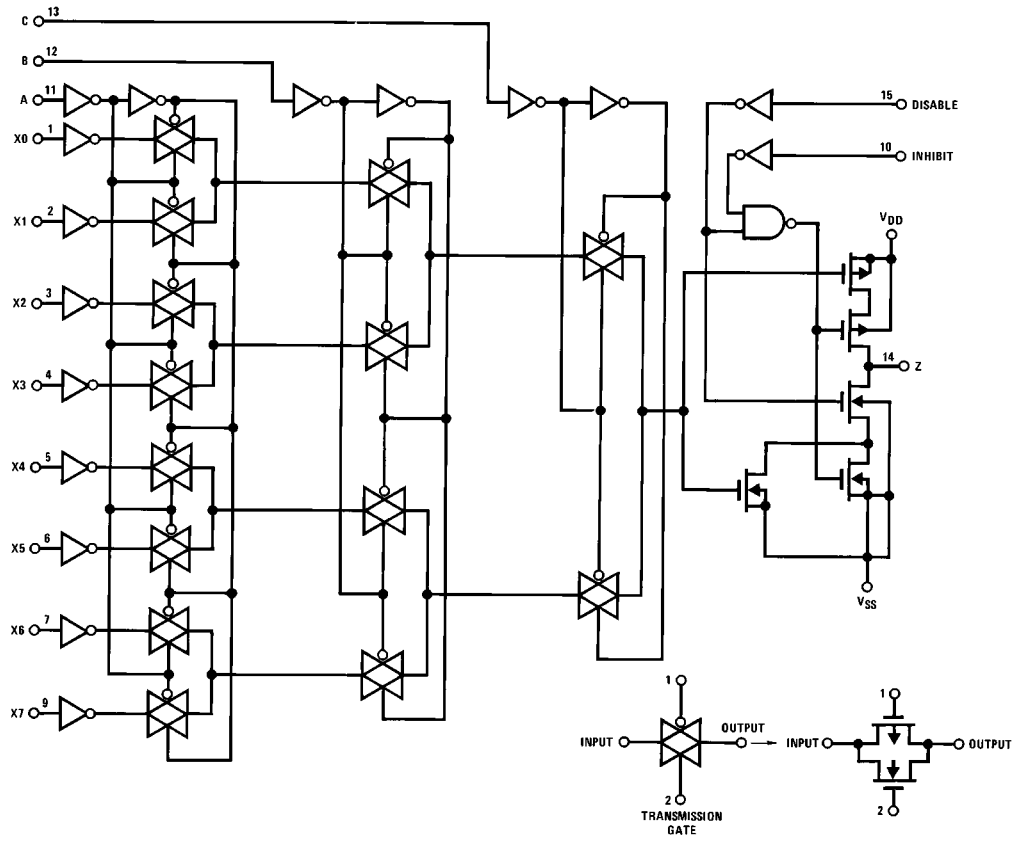

Absolute Maximum Ratings (Note 1)		Recommended Operating Conditions (Note 2)	
Supply Voltage (V_{DD})	-0.5 to +18 V_{DC}	DC Supply Voltage (V_{DD})	3.0 to 15 V_{DC}
Input Voltage (V_{IN})	-0.5 to $V_{DD} + 0.5 V_{DC}$	Input Voltage (V_{IN})	0 to $V_{DD} V_{DC}$
Storage Temperature Range (T_S)	-65°C to +150°C	Operating Temperature Range (T_A)	-40°C to +85°C
Power Dissipation (P_D)		Note 1: "Absolute Maximum Ratings" are those values beyond which the safety of the device cannot be guaranteed. They are not meant to imply that the devices should be operated at these limits. The Recommended Operating Conditions and Electrical Characteristics table provide conditions for actual device operation.	
Dual-In-Line	700 mW	Note 2: $V_{SS} = 0V$ unless otherwise specified.	
Small Outline	500 mW		
Lead Temperature, (T_L)			
(Soldering, 10 seconds)	260°C		

DC Electrical Characteristics (Note 2)

Symbol	Parameter	Conditions	-40°C		+25°C			+85°C		Units	
			Min	Max	Min	Typ	Max	Min	Max		
I_{DD}	Quiescent Device Current	$V_{DD} = 5V, V_{IN} = V_{DD}$ or V_{SS}		20		0.005	20		150	μA	
		$V_{DD} = 10V, V_{IN} = V_{DD}$ or V_{SS}		40		0.010	40		300	μA	
		$V_{DD} = 15V, V_{IN} = V_{DD}$ or V_{SS}		80		0.015	80		600	μA	
V_{OL}	LOW Level Output Voltage	$V_{DD} = 5V$		0.05		0	0.05		0.05	V	
		$V_{DD} = 10V$	$ I_{OL} < 1 \mu A$		0.05		0	0.05		0.05	V
		$V_{DD} = 15V$			0.05		0	0.05		0.05	V
V_{OH}	HIGH Level Output Voltage	$V_{DD} = 5V$	4.95		4.95	5.0		4.95		V	
		$V_{DD} = 10V$	9.95		9.95	10.0		9.95		V	
		$V_{DD} = 15V$	14.95		14.95	15.0		14.95		V	
V_{IL}	LOW Level Input Voltage	$V_{DD} = 5V, V_O = 0.5V$		1.5		2.25	1.5		1.5	V	
		$V_{DD} = 10V, V_O = 1.0V$		3.0		4.50	3.0		3.0	V	
		$V_{DD} = 15V, V_O = 1.5V$		4.0		6.75	4.0		4.0	V	
V_{IH}	HIGH Level Input Voltage	$V_{DD} = 5V, V_O = 4.5V$	3.5		3.5	2.75		3.5		V	
		$V_{DD} = 10V, V_O = 9.0V$	7.0		7.0	5.50		7.0		V	
		$V_{DD} = 15V, V_O = 13.5V$	11.0		11.0	8.25		11.0		V	
I_{OL}	LOW Level Output Current (Note 3)	$V_{DD} = 5V, V_O = 0.4V$	0.52		0.44	0.78		0.36		mA	
		$V_{DD} = 10V, V_O = 0.5V$	1.3		1.1	2.0		0.9		mA	
		$V_{DD} = 15V, V_O = 1.5V$	3.6		3.4	7.8		2.4		mA	
I_{OH}	HIGH Level Output Current (Note 3)	$V_{DD} = 5V, V_O = 4.6V$	-0.2		-0.16			-0.12		mA	
		$V_{DD} = 10V, V_O = 9.5$	-0.5		-0.4			-0.3		mA	
		$V_{DD} = 15V, V_O = 13.5V$	-1.4		-1.2			-1.0		mA	
I_{IN}	Input Current	$V_{DD} = 15V, V_{IN} = 0V$		-0.3		-10^{-5}	-0.3		-1.0	μA	
		$V_{DD} = 15V, V_{IN} = 15V$		0.3		10^{-5}	0.3		1.0	μA	
I_{OZ}	3-STATE Output Current	$V_{DD} = 15V, V_O = 0V$		± 1.0		$\pm 10^{-5}$	± 1.0		± 7.5	μA	

Note 3: I_{OH} and I_{OL} are tested one output at a time.

AC Electrical Characteristics (Note 4) $T_A = 25^\circ\text{C}$, $t_r = t_f = 20 \text{ ns}$, $C_L = 50 \text{ pF}$

Symbol	Parameter	Conditions	CD4512BM			CD4512BC			Units
			Min	Typ	Max	Min	Typ	Max	
t_{PHL}	Propagation Delay HIGH-to-LOW Level	$V_{DD} = 5\text{V}$		225	500		225	750	ns
		$V_{DD} = 10\text{V}$		75	175		75	200	ns
		$V_{DD} = 15\text{V}$		57	130		57	150	ns
t_{PLH}	Propagation Delay LOW-to-HIGH Level	$V_{DD} = 5\text{V}$		225	500		225	750	ns
		$V_{DD} = 10\text{V}$		75	175		75	200	ns
		$V_{DD} = 15\text{V}$		57	130		57	150	ns
t_{THL} , t_{TLH}	Transition Time	$V_{DD} = 5\text{V}$		70	200		70	200	ns
		$V_{DD} = 10\text{V}$		35	100		35	100	ns
		$V_{DD} = 15\text{V}$		25	80		25	80	ns
t_{PHZ} , t_{PLZ}	Propagation Delay into 3-STATE from Logic Level	$V_{DD} = 5\text{V}$		50	125		50	125	ns
		$V_{DD} = 10\text{V}$		25	75		25	75	ns
		$V_{DD} = 15\text{V}$		19	60		19	60	ns
t_{PZH} , t_{PZL}	Propagation Delay to Logic Level from 3-STATE	$V_{DD} = 5\text{V}$		50	125		50	125	ns
		$V_{DD} = 10\text{V}$		25	75		25	75	ns
		$V_{DD} = 15\text{V}$		19	60		19	60	ns
C_{IN}	Input Capacitance	(Note 5)		7.5	15		7.5	15	pF
C_{OUT}	3-STATE Output Capacitance	(Note 5)		7.5	15		7.5	15	pF
C_{PD}	Power Dissipation Capacity	(Note 6)		150			150		pF

Note 4: AC Parameters are guaranteed by DC correlated testing.**Note 5:** Capacitance guaranteed by periodic testing.**Note 6:** C_{PD} determines the no load AC power of any CMOS device. For complete explanation, see Family Characteristics Application Note, AN-90.

Typical Application

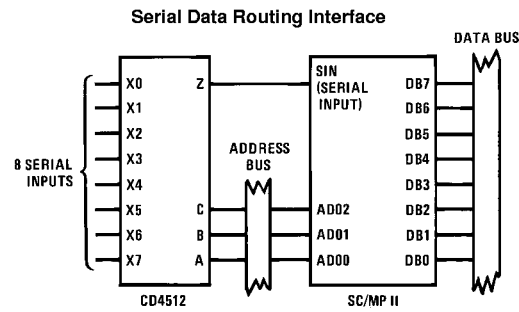

AC Test Circuit and Switching Time Waveforms

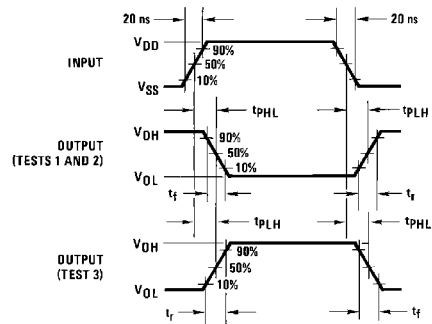
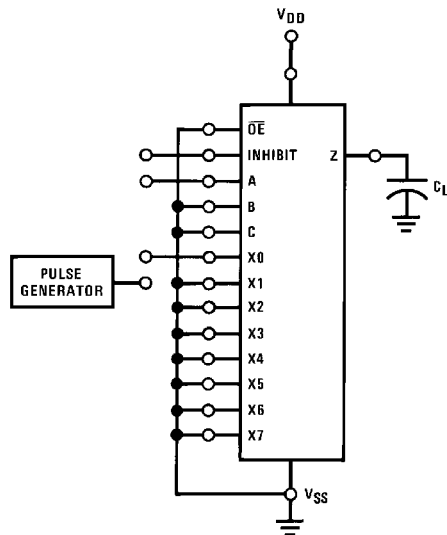

Input Connections for t_r , t_f , t_{PLH} , t_{PHL}

Test	Inhibit	A	X0
1	PG	GND	V_{DD}
2	GND	PG	V_{DD}
3	GND	GND	PG

3-STATE AC Test Circuit and Switching Time Waveforms

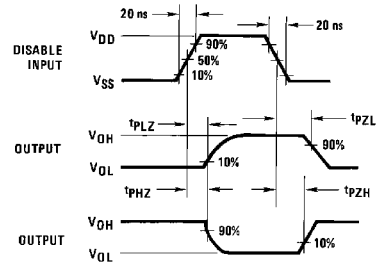
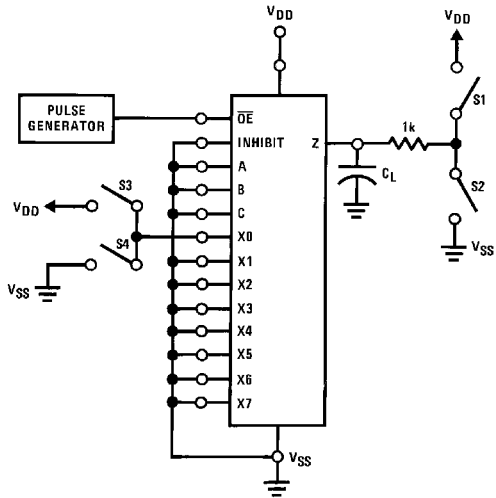

Switch Positions for 3-STATE Test

Test	S1	S2	S3	S4
t_{PHZ}	Open	Closed	Closed	Open
t_{PLZ}	Closed	Open	Open	Closed
t_{PZH}	Open	Closed	Closed	Open
t_{PZL}	Closed	Open	Open	Closed

Physical Dimensions inches (millimeters) unless otherwise noted

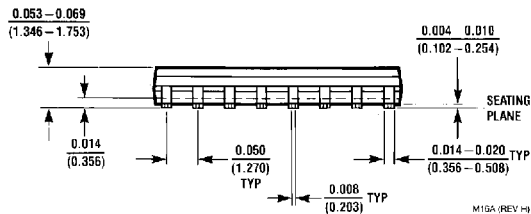
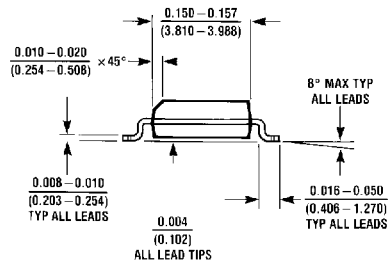
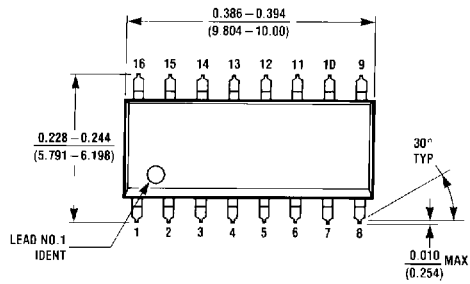

M16A (REV H)

**16-Lead Small Outline Integrated Circuit (SOIC), JEDEC MS-012, 0.150" Wide
Package Number M16A**

Physical Dimensions inches (millimeters) unless otherwise noted (Continued)

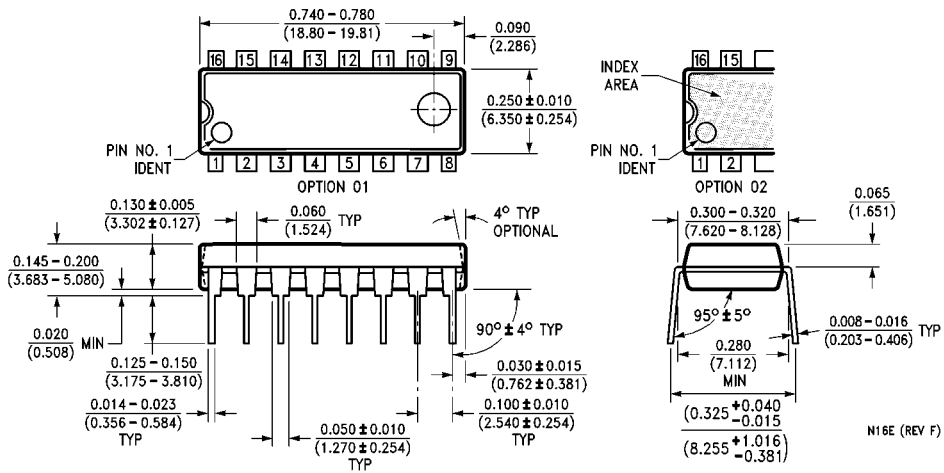

16-Lead Plastic Dual-In-Line Package (PDIP), JEDEC MS-001, 0.300" Wide Package Number N16E

LIFE SUPPORT POLICY

FAIRCHILD'S PRODUCTS ARE NOT AUTHORIZED FOR USE AS CRITICAL COMPONENTS IN LIFE SUPPORT DEVICES OR SYSTEMS WITHOUT THE EXPRESS WRITTEN APPROVAL OF THE PRESIDENT OF FAIRCHILD SEMICONDUCTOR CORPORATION. As used herein:

1. Life support devices or systems are devices or systems which, (a) are intended for surgical implant into the body, or (b) support or sustain life, and (c) whose failure to perform when properly used in accordance with instructions for use provided in the labeling, can be reasonably expected to result in a significant injury to the user.
2. A critical component in any component of a life support device or system whose failure to perform can be reasonably expected to cause the failure of the life support device or system, or to affect its safety or effectiveness.

www.fairchildsemi.com