



MM54HCT688/MM74HCT688 8-Bit Magnitude Comparator (Equality Detector)

General Description

This equality detector utilizes advanced silicon-gate CMOS technology to compare bit for bit two 8-bit words and indicate whether or not they are equal. The $\overline{P=Q}$ output indicates equality when it is low. A single active low enable is provided to facilitate cascading of several packages and enable comparison of words greater than 8 bits.

This device is useful in memory block decoding applications, where memory block enable signals must be generated from computer address information.

The comparator combines the low power consumption of CMOS, but inputs are compatible with TTL logic levels, and the output can drive 10 low power Schottky equivalent loads.

MM54HCT/MM74HCT devices are intended to interface between TTL and NMOS components and standard CMOS devices. These parts are also plug in replacements for LS-TTL devices and can be used to reduce power consumption in existing designs.

All inputs are protected from damage due to static discharge by diodes to V_{CC} and ground.

Features

- TTL input compatible
- Typical propagation delay: 20 ns
- Low quiescent current: 80 μ A maximum (74HCT Series)
- Large output current: 4 mA
- Same as HCT521

Logic Diagrams

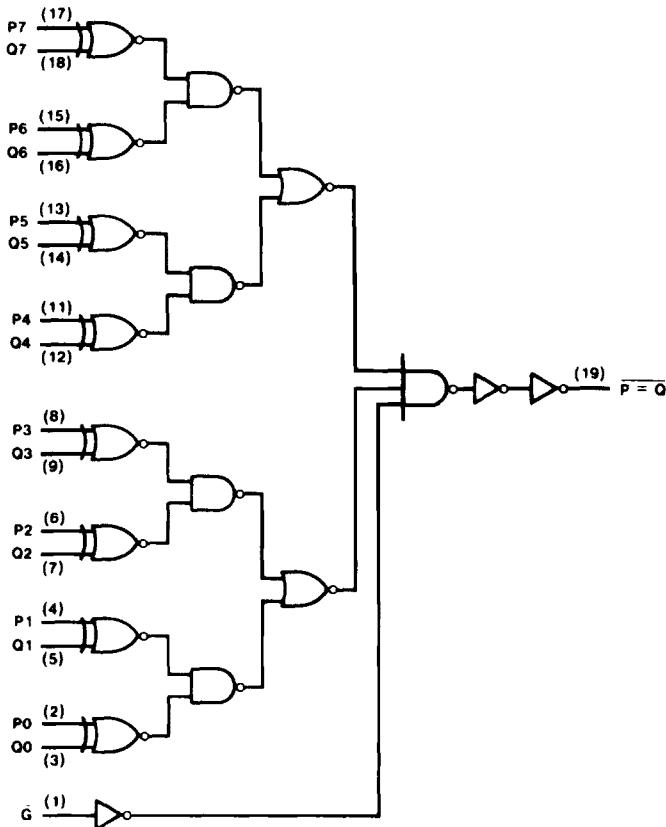

TL/F/5371-2

Absolute Maximum Ratings (Notes 1 & 2)

If Military/Aerospace specified devices are required, contact the National Semiconductor Sales Office/Distributors for availability and specifications.

Supply Voltage (V_{CC})	-0.5 to +7.0V
DC Input Voltage (V_{IN})	-1.5 to $V_{CC} + 1.5V$
DC Output Voltage (V_{OUT})	-0.5 to $V_{CC} + 0.5V$
Clamp Diode Current (I_{IK}, I_{OK})	± 20 mA
DC Output Current, per pin (I_{OUT})	± 25 mA
DC V_{CC} or GND Current, per pin (I_{CC})	± 50 mA
Storage Temperature Range (T_{STG})	-65°C to +150°C
Power Dissipation (P_D)	
(Note 3)	600 mW
S.O. Package only	500 mW
Lead Temperature (T_L)	
(Soldering 10 seconds)	260°C

Operating Conditions

	Min	Max	Units
Supply Voltage (V_{CC})	4.5	5.5	V
DC Input or Output Voltage (V_{IN}, V_{OUT})	0	V_{CC}	V
Operating Temp. Range (T_A)			
MM74HCT688	-40	+85	°C
MM54HCT688	-55	+125	°C
Input Rise or Fall Times (t_r, t_f)		500	ns

DC Electrical Characteristics ($V_{CC} = 5V \pm 10\%$ unless otherwise specified)

Symbol	Parameter	Conditions	$T_A = 25^\circ C$		74HCT	54HCT	Units
			Typ	Guaranteed Limits			
V_{IH}	Minimum High Level Input Voltage			2.0	2.0	2.0	V
V_{IL}	Maximum Low Level Input Voltage			0.8	0.8	0.8	V
V_{OH}	Minimum High Level Output Voltage	$V_{IN} = 0.8V$ or $2.0V$ $I_{OUT} = 20 \mu A$ $I_{OUT} = 4.0$ mA, $V_{CC} = 4.5V$ $I_{OUT} = 4.8$ mA, $V_{CC} = 5.5V$	V_{CC}	$V_{CC} - 0.1$	$V_{CC} - 0.1$	$V_{CC} - 0.1$	V
			4.2	3.98	3.84	3.7	V
			5.7	4.98	4.84	4.7	V
V_{OL}	Maximum Low Level Output Voltage	$V_{IN} = 0.8V$ or $2.0V$ $I_{OUT} = 20 \mu A$ $I_{OUT} = 4.0$ mA, $V_{CC} = 4.5V$ $I_{OUT} = 4.8$ mA, $V_{CC} = 5.5V$	0	0.1	0.1	0.1	V
			0.2	0.26	0.33	0.4	V
			0.2	0.26	0.33	0.4	V
I_{IN}	Maximum Input Current	$V_{IN} = V_{CC}$ or GND		± 0.1	± 1.0	± 1.0	μA
I_{CC}	Maximum Quiescent Supply Current	$V_{IN} = V_{CC}$ or GND $I_{OUT} = 0 \mu A$		8.0	80	160	μA
		$V_{IN} = 2.4V$ or $0.5V$ (Note 4)		0.3	0.4	0.5	mA

Note 1: Absolute Maximum Ratings are those values beyond which damage to the device may occur.

Note 2: Unless otherwise specified all voltages are referenced to ground.

Note 3: Power Dissipation temperature derating — plastic "N" package: -12 mW/°C from 65°C to 85°C; ceramic "J" package: -12 mW/°C from 100°C to 125°C.

Note 4: Measured per pin. All other inputs held at V_{CC} or ground.

AC Electrical Characteristics

$V_{CC} = 5V, T_A = 25^\circ C, C_L = 15 pF, t_r = t_f = 6 ns$ (unless otherwise specified)

Symbol	Parameter	Conditions	Typ	Guaranteed Limit	Units
t_{PHL}	Maximum Propagation Delay - P or Q to Output		19	30	ns
t_{PLH}	Maximum Propagation Delay - P or Q to Output		13	22	ns
t_{PHL}	Maximum Propagation Delay - Enable to Output		13	20	ns
t_{PHL}	Maximum Propagation Delay - Enable to Output		10	18	ns

AC Electrical Characteristics

$V_{CC} = 5V \pm 10\%, C_L = 50 pF, t_r = t_f = 6 ns$ (unless otherwise specified)

Symbol	Parameter	Conditions	$T_A = 25^\circ C$		74HCT	54HCT	Units
			Typ	Guaranteed Limits	$T_A = -40 to 85^\circ C$	$T_A = -55 to 125^\circ C$	
t_{PHL}	Maximum Propagation Delay - P or Q to Output		23	35	44	53	ns
t_{PLH}	Maximum Propagation Delay - P or Q to Output		16	24	30	36	ns
t_{PHL}	Maximum Propagation Delay - Enable to Output		16	24	30	36	ns
t_{PLH}	Maximum Propagation Delay - Enable to Output		11	20	25	30	ns
t_{THL}, t_{TLH}	Maximum Output Rise and Fall Time		8	15	19	22	ns
C_{PD}	Power Dissipation Capacitance (Note 5)		45				pF
C_{IN}	Maximum Input Capacitance		5	10	10	10	pF

Note 5: C_{PD} determines the no load dynamic power consumption, $P_D = C_{PD} V_{CC}^2 f + I_{CC} V_{CC}$, and the no load dynamic current consumption, $I_S = C_{PD} V_{CC} + I_{CC}$.

Connection Diagram

Dual-In-Line Package

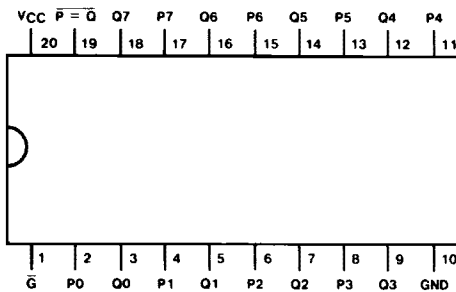

Top View

Order Number MM54HCT688* or MM74HCT688*

*Please look into Section 8, Appendix D for availability of various package types.

Truth Table

Inputs		$P=Q$
Data	Enable	
P, Q	\bar{G}	
P=Q	L	L
P>Q	L	H
P<Q	L	H
X	H	H

TL/F/5371-1