

T-52-09

541



54AC/74AC541

Octal Buffer/Line Driver with TRI-STATE® Outputs

General Description

The 'AC541 is an octal buffer/line driver designed to be employed as memory and address drivers, clock drivers and bus oriented transmitter/receivers. The 'AC541 is a noninverting option of the 'AC540.

This device is similar in function to the 'AC244 while providing flow-through architecture (inputs on opposite side from outputs). This pinout arrangement makes this device especially useful as an output port for microprocessors, allowing ease of layout and greater PC board density.

Features

- I_{CC} and I_{OZ} reduced by 50%
- TRI-STATE outputs
- Inputs and outputs opposite side of package, allowing easier interface to microprocessors
- Output source/sink 24 mA
- 'AC540 provides inverted outputs
- Standard Military Drawing (SMD)
 - 'AC541: 5962-88706

Ordering Code: See Section 8

Logic Symbol

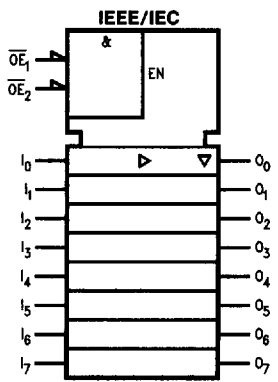

TL/F/9967-3

Connection Diagrams

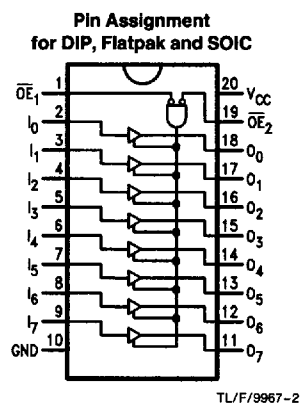

TL/F/9967-2

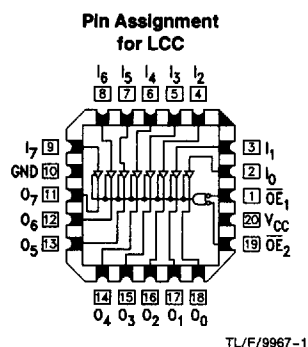

TL/F/9967-1

Truth Table

Inputs			Outputs
\overline{OE}_1	\overline{OE}_2	I	
L	L	H	H
H	X	X	Z
X	H	X	Z
L	L	L	L

H = HIGH Voltage Level
 L = LOW Voltage Level
 X = Immaterial
 Z = High Impedance

Absolute Maximum Rating (Note 1)

If Military/Aerospace specified devices are required, please contact the National Semiconductor Sales Office/Distributors for availability and specifications.

Supply Voltage (V _{CC})	-0.5V to +7.0V
DC Input Diode Current (I _{IK})	
V _I = -0.5V	-20 mA
V _I = V _{CC} + 0.5V	+20 mA
DC Input Voltage (V _I)	-0.5V to V _{CC} + 0.5V
DC Output Diode Current (I _{OK})	
V _O = -0.5V	-20 mA
V _O = V _{CC} + 0.5V	+20 mA
DC Output Voltage (V _O)	-0.5V to V _{CC} + 0.5V
DC Output Source or Sink Current (I _O)	±50 mA
DC V _{CC} or Ground Current per Output Pin (I _{CC} or I _{GND})	±50 mA
Storage Temperature (T _{STG})	-65°C to +150°C
Junction Temperature (T _J)	
CDIP	175°C
PDIP	140°C

Note 1: Absolute maximum ratings are those values beyond which damage to the device may occur. The databook specifications should be met, without exception, to ensure that the system design is reliable over its power supply, temperature, and output/input loading variables. National does not recommend operation of FACTM circuits outside databook specifications.

Recommended Operating Conditions

Supply Voltage (V _{CC})	2.0V to 6.0V
'AC	
Input Voltage (V _I)	0V to V _{CC}
Output Voltage (V _O)	0V to V _{CC}
Operating Temperature (T _A)	
74AC	-40°C to +85°C
54AC	-55°C to +125°C
Minimum Input Edge Rate (ΔV/Δt)	
'AC Devices	
V _{IN} from 30% to 70% of V _{CC}	
V _{CC} @ 3.3V, 4.5V, 5.5V	125 mV/ns

DC Characteristics for 'AC Family Devices

Symbol	Parameter	V _{CC} (V)	74AC			54AC		74AC		Units	Conditions
			T _A = +25°C			T _A = -55°C to +125°C		T _A = -40°C to +85°C			
			Typ	Guaranteed Limits		Guaranteed Limits		Guaranteed Limits			
V _{IH}	Minimum High Level Input Voltage	3.0	1.5	2.1	2.1		2.1		V	V _{OUT} = 0.1V or V _{CC} - 0.1V	
		4.5	2.25	3.15	3.15		3.15				
		5.5	2.75	3.85	3.85		3.85				
V _{IL}	Maximum Low Level Input Voltage	3.0	1.5	0.9	0.9		0.9		V	V _{OUT} = 0.1V or V _{CC} - 0.1V	
		4.5	2.25	1.35	1.35		1.35				
		5.5	2.75	1.65	1.65		1.65				
V _{OH}	Minimum High Level Output Voltage	3.0	2.99	2.9	2.9		2.9		V	I _{OUT} = -50 μA	
		4.5	4.49	4.4	4.4		4.4				
		5.5	5.49	5.4	5.4		5.4				
			3.0		2.56	2.4		2.46		V	*V _{IN} = V _{IL} or V _{IH} -12 mA I _{OH} -24 mA -24 mA
			4.5		3.86	3.7		3.76			
			5.5		4.86	4.7		4.76			
V _{OL}	Maximum Low Level Output Voltage	3.0	0.002	0.1	0.1		0.1		V	I _{OUT} = 50 μA	
		4.5	0.001	0.1	0.1		0.1				
		5.5	0.001	0.1	0.1		0.1				
			3.0		0.36	0.50		0.44		V	*V _{IN} = V _{IL} or V _{IH} 12 mA I _{OL} 24 mA 24 mA
			4.5		0.36	0.50		0.44			
			5.5		0.36	0.50		0.44			
I _{IN}	Maximum Input Leakage Current	5.5		±0.1	±1.0		±1.0		μA	V _I = V _{CC} , GND	

*All outputs loaded; thresholds on input associated with output under test.

DC Characteristics for 'AC Family Devices (Continued)

Symbol	Parameter	V _{CC} (V)	74AC		54AC		74AC		Units	Conditions
			T _A = +25°C		T _A = -55°C to +125°C		T _A = -40°C to +85°C			
			Typ	Guaranteed Limits						
I _{OZ}	Maximum TRI-STATE® Leakage Current	5.5		±0.25	±5.0	±2.5			μA	V _I (OE) = V _{IL} , V _{IH} V _I = V _{CC} , GND V _O = V _{CC} , GND
I _{OLD}	†Minimum Dynamic Output Current	5.5			50	75			mA	V _{OLD} = 1.65V Max
I _{OHD}		5.5			-50	-75			mA	V _{OHD} = 3.85V Min
I _{CC}	Maximum Quiescent Supply Current	5.5		4.0	80.0	40.0			μA	V _{IN} = V _{CC} or GND

†Maximum test duration 2.0 ms, one output loaded at a time.

Note: I_{IN} and I_{CC} @ 3.0V are guaranteed to be less than or equal to the respective limit @ 5.5V V_{CC}. I_{CC} for 54AC @ 25°C is identical to 74AC @ 25°C.

AC Electrical Characteristics: See Section 2 for Waveforms

Symbol	Parameter	V _{CC} * (V)	74AC			54AC		74AC		Units	Fig. No.
			T _A = +25°C C _L = 50 pF			T _A = -55°C to +125°C C _L = 50 pF		T _A = -40°C to +85°C C _L = 50 pF			
			Min	Typ	Max	Min	Max	Min	Max		
t _{PLH}	Propagation Delay Data to Output	3.3	2.0	5.5	8.0	1.0	10.0	1.5	9.0	ns	2-3, 4
		5.0	1.5	4.0	6.0	1.5	7.0	1.0	6.5		
t _{PHL}	Propagation Delay Data to Output	3.3	2.0	5.5	8.0	1.0	9.5	1.5	8.5	ns	2-3, 4
		5.0	1.5	4.0	6.0	1.5	7.0	1.0	6.5		
t _{pZH}	Output Enable Time	3.3	3.0	8.0	11.5	1.0	13.5	3.0	12.5	ns	2-5
		5.0	2.0	6.0	8.5	1.5	10.0	1.5	9.5		
t _{pZL}	Output Enable Time	3.3	2.5	7.0	10.0	1.0	12.5	2.5	11.5	ns	2-6
		5.0	1.5	5.5	7.5	1.5	9.0	1.0	8.5		
t _{pHZ}	Output Disable Time	3.3	3.5	9.0	12.5	1.0	15.0	2.5	14.0	ns	2-5
		5.0	2.0	7.0	9.5	1.5	12.0	1.0	10.5		
t _{pLZ}	Output Disable Time	3.3	2.5	6.5	9.5	1.0	11.0	2.0	10.5	ns	2-6
		5.0	2.0	5.5	7.5	1.5	9.0	1.0	8.5		

*Voltage Range 3.3 is 3.3V ±0.3V
Voltage Range 5.0 is 5.0V ±0.5V

Capacitance

Symbol	Parameter	Typ	Units	Conditions
C _{IN}	Input Capacitance	4.5	pF	V _{CC} = OPEN
C _{PD}	Power Dissipation Capacitance	30.0	pF	V _{CC} = 5.0V