

## CD40174BC • CD40175BC Hex D-Type Flip-Flop • Quad D-Type Flip-Flop

### General Description

The CD40174BC consists of six positive-edge triggered D-type flip-flops; the true outputs from each flip-flop are externally available. The CD40175BC consists of four positive-edge triggered D-type flip-flops; both the true and complement outputs from each flip-flop are externally available.

All flip-flops are controlled by a common clock and a common clear. Information at the D inputs meeting the set-up time requirements is transferred to the Q outputs on the positive-going edge of the clock pulse. The clearing operation, enabled by a negative pulse at Clear input, clears all Q outputs to logical "0" and  $\bar{Q}$ s (CD40175BC only) to logical "1".

All inputs are protected from static discharge by diode clamps to  $V_{DD}$  and  $V_{SS}$ .

### Features

- Wide supply voltage range: 3V to 15V
- High noise immunity:  $0.45 V_{DD}$  (typ.)
- Low power TTL compatibility:  
fan out of 2 driving 74L or 1 driving 74 LS
- Equivalent to MC14174B, MC14175B
- Equivalent to MM74C174, MM74C175

### Ordering Code:

Order Number	Package Number	Package Description
CD40174BCM	M16A	16-Lead Small Outline Integrated Circuit (SOIC), JEDEC MS-012, 0.150" Narrow Body
CD40174BCN	N16E	16-Lead Plastic Dual-In-Line Package (PDIP), JEDEC MS-001, 0.300" Wide
CD40175BCM	M16A	16-Lead Small Outline Integrated Circuit (SOIC), JEDEC MS-012, 0.150" Narrow Body
CD40175BCN	N16E	16-Lead Plastic Dual-In-Line Package (PDIP), JEDEC MS-001, 0.300" Wide

Devices also available in Tape and Reel. Specify by appending the suffix letter "X" to the ordering code.

### Connection Diagrams

Pin Assignments for DIP and SOIC

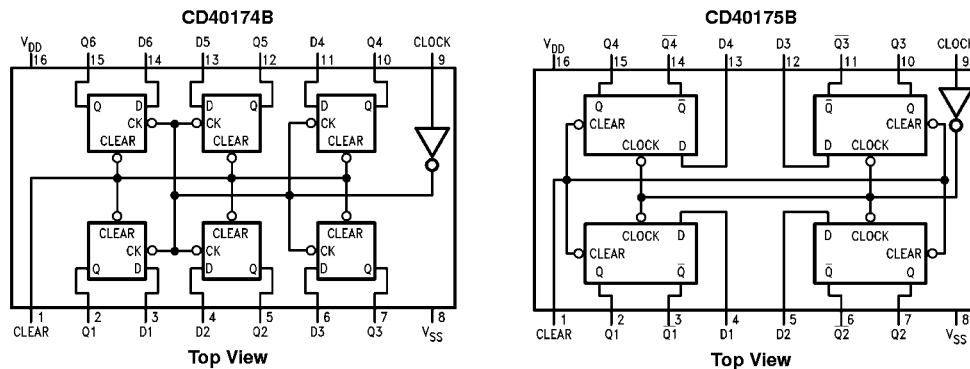

**Truth Table**

Inputs			Outputs	
Clear	Clock	D	Q	$\bar{Q}$ (Note 1)
L	X	X	L	H
H	↑	H	H	L
H	↑	L	L	H
H	H	X	NC	NC
H	L	X	NC	NC

H = HIGH Level  
 L = LOW Level  
 X = Irrelevant  
 ↑ = Transition from LOW-to-HIGH level  
 NC = No change

**Note 1:**  $\bar{Q}$  for CD40175B only

### Absolute Maximum Ratings (Note 2)

(Note 3)

DC Supply Voltage ( $V_{DD}$ )	-0.5V to +18V
Input Voltage ( $V_{IN}$ )	-0.5V to $V_{DD} + 0.5V_{DC}$
Storage Temperature Range ( $T_S$ )	-65°C to +150°C
Power Dissipation ( $P_D$ )	
Dual-In-Line	700 mW
Small Outline	500 mW
Lead Temperature ( $T_L$ )	
(Soldering, 10 seconds)	260°C

### Recommended Operating Conditions (Note 3)

DC Supply Voltage ( $V_{DD}$ )	3V to 15 $V_{DC}$
Input Voltage ( $V_{IN}$ )	0V to $V_{DD}$ $V_{DC}$
Operating Temperature Range ( $T_A$ )	-40°C to +85°C

**Note 2:** "Absolute Maximum Ratings" are those values beyond which the safety of the device cannot be guaranteed. They are not meant to imply that the devices should be operated at these limits. The tables of "Recommended Operating Conditions" and "Electrical Characteristics" provide conditions for actual device operation.

**Note 3:**  $V_{SS} = 0V$  unless otherwise specified.

### DC Electrical Characteristics (Note 3)

CD40174BC/CD40175BC

Symbol	Parameter	Conditions	-40°C		+25°C			+85°C		Units
			Min	Max	Min	Typ	Max	Min	Max	
$I_{DD}$	Quiescent Device Current	$V_{DD} = 5V, V_{IN} = V_{DD}$ or $V_{SS}$		4			4		30	$\mu A$
		$V_{DD} = 10V, V_{IN} = V_{DD}$ or $V_{SS}$		8			8		60	$\mu A$
		$V_{DD} = 15V, V_{IN} = V_{DD}$ or $V_{SS}$		16			16		120	$\mu A$
$V_{OL}$	LOW Level Output Voltage	$V_{DD} = 5V$		0.05			0.05		0.05	V
		$V_{DD} = 10V$		0.05			0.05		0.05	V
		$V_{DD} = 15V$		0.05			0.05		0.05	V
$V_{OH}$	HIGH Level Output Voltage	$V_{DD} = 5V$	4.95		4.95	5		4.95		V
		$V_{DD} = 10V$	9.95		9.95	10		9.95		V
		$V_{DD} = 15V$	14.95		14.95	15		14.95		V
$V_{IL}$	LOW Level Input Voltage	$V_{DD} = 5V, V_O = 0.5V$ or 4.5V		1.5			1.5		1.5	V
		$V_{DD} = 10V, V_O = 1V$ or 9V		3.0			3.0		3.0	V
		$V_{DD} = 15V, V_O = 1.5V$ or 13.5V		4.0			4.0		4.0	V
$V_{IH}$	HIGH Level Input Voltage	$V_{DD} = 5V, V_O = 0.5V$ or 4.5V	3.5		3.5			3.5		V
		$V_{DD} = 10V, V_O = 1V$ or 9V	7.0		7.0			7.0		V
		$V_{DD} = 15V, V_O = 1.5V$ or 13.5V	11.0		11.0			11.0		V
$I_{OL}$	LOW Level Output Current (Note 4)	$V_{DD} = 5V, V_O = 0.4V$	0.52		0.44	0.88		0.36		mA
		$V_{DD} = 10V, V_O = 0.5V$	1.3		1.1	2.25		0.9		mA
		$V_{DD} = 15V, V_O = 1.5V$	3.6		3.0	8.8		2.4		mA
$I_{OH}$	HIGH Level Output Current (Note 4)	$V_{DD} = 5V, V_O = 4.6V$	-0.52		-0.44	-0.88		-0.36		mA
		$V_{DD} = 10V, V_O = 9.5V$	-1.3		-1.1	-2.25		-0.9		mA
		$V_{DD} = 15V, V_O = 13.5V$	-3.6		-3.0	-8.8		-2.4		mA
$I_{IN}$	Input Current	$V_{DD} = 15V, V_{IN} = 0V$		-0.30		$-10^{-5}$	-0.30		-1.0	$\mu A$
		$V_{DD} = 15V, V_{IN} = 15V$		0.30		$10^{-5}$	0.30		1.0	$\mu A$

**Note 4:**  $I_{OH}$  and  $I_{OL}$  are tested one output at a time.

**AC Electrical Characteristics** (Note 5)

T<sub>A</sub> = 25°C, C<sub>L</sub> = 50 pF, R<sub>L</sub> = 200k and t<sub>r</sub> = t<sub>f</sub> = 20 ns, unless otherwise specified

Symbol	Parameter	Conditions	Min	Typ	Max	Units
t <sub>PHL</sub> , t <sub>PLH</sub>	Propagation Delay Time to a Logical "0" or Logical "1" from Clock to Q or $\bar{Q}$ (CD40175 Only)	V <sub>DD</sub> = 5V		190	300	ns
		V <sub>DD</sub> = 10V		75	110	ns
		V <sub>DD</sub> = 15V		60	90	ns
t <sub>PHL</sub>	Propagation Delay Time to a Logical "0" from Clear to Q	V <sub>DD</sub> = 5V		180	300	ns
		V <sub>DD</sub> = 10V		70	110	ns
		V <sub>DD</sub> = 15V		60	90	ns
t <sub>PLH</sub>	Propagation Delay Time to a Logical "1" from Clear to $\bar{Q}$ (CD40175 Only)	V <sub>DD</sub> = 5V		230	400	ns
		V <sub>DD</sub> = 10V		90	150	ns
		V <sub>DD</sub> = 15V		75	120	ns
t <sub>SU</sub>	Time Prior to Clock Pulse that Data must be Present	V <sub>DD</sub> = 5V		45	100	ns
		V <sub>DD</sub> = 10V		15	40	ns
		V <sub>DD</sub> = 15V		13	35	ns
t <sub>H</sub>	Time after Clock Pulse that Data Must be Held	V <sub>DD</sub> = 5V		-11	0	ns
		V <sub>DD</sub> = 10V		-4	0	ns
		V <sub>DD</sub> = 15V		-3	0	ns
t <sub>THL</sub> , t <sub>TLH</sub>	Transition Time	V <sub>DD</sub> = 5V		100	200	ns
		V <sub>DD</sub> = 10V		50	100	ns
		V <sub>DD</sub> = 15V		40	80	ns
t <sub>WH</sub> , t <sub>WL</sub>	Minimum Clock Pulse Width	V <sub>DD</sub> = 5V		130	250	ns
		V <sub>DD</sub> = 10V		45	100	ns
		V <sub>DD</sub> = 15V		40	80	ns
t <sub>WL</sub>	Minimum Clear Pulse Width	V <sub>DD</sub> = 5V		120	250	ns
		V <sub>DD</sub> = 10V		45	100	ns
		V <sub>DD</sub> = 15V		40	80	ns
t <sub>RCL</sub>	Maximum Clock Rise Time	V <sub>DD</sub> = 5V	15			μs
		V <sub>DD</sub> = 10V	5.0			μs
		V <sub>DD</sub> = 15V	5.0			μs
t <sub>fCL</sub>	Maximum Clock Fall Time	V <sub>DD</sub> = 5V	15	50		μs
		V <sub>DD</sub> = 10V	5.0	50		μs
		V <sub>DD</sub> = 15V	5.0	50		μs
f <sub>CL</sub>	Maximum Clock Frequency	V <sub>DD</sub> = 5V	2.0	3.5		MHz
		V <sub>DD</sub> = 10V	5.0	10		MHz
		V <sub>DD</sub> = 15V	6.0	12		MHz
C <sub>IN</sub>	Input Capacitance	Clear Input		10	15	pF
		Other Input		5.0	7.5	pF
C <sub>PD</sub>	Power Dissipation	Per Package (Note 6)		130		pF

**Note 5:** AC Parameters are guaranteed by DC correlated testing.

**Note 6:** C<sub>PD</sub> determines the no load AC power consumption of any CMOS device. For complete explanation, see 74C Family Characteristics application note, AN-90.

Switching Time Waveforms

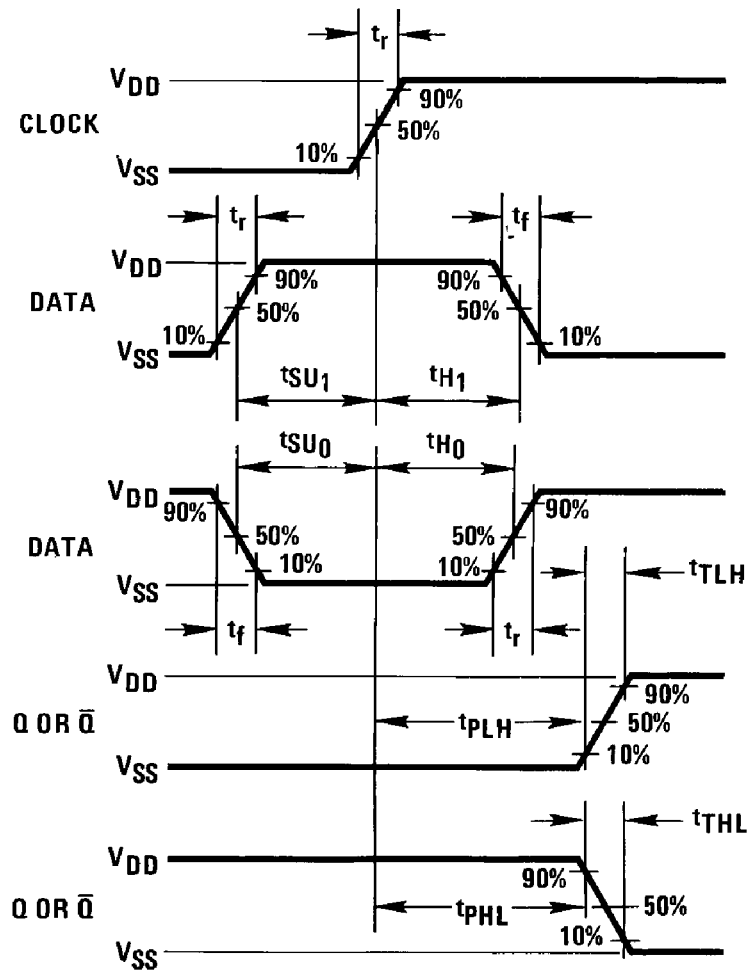

$t_r = t_f = 20 \text{ ns}$

**Physical Dimensions** inches (millimeters) unless otherwise noted

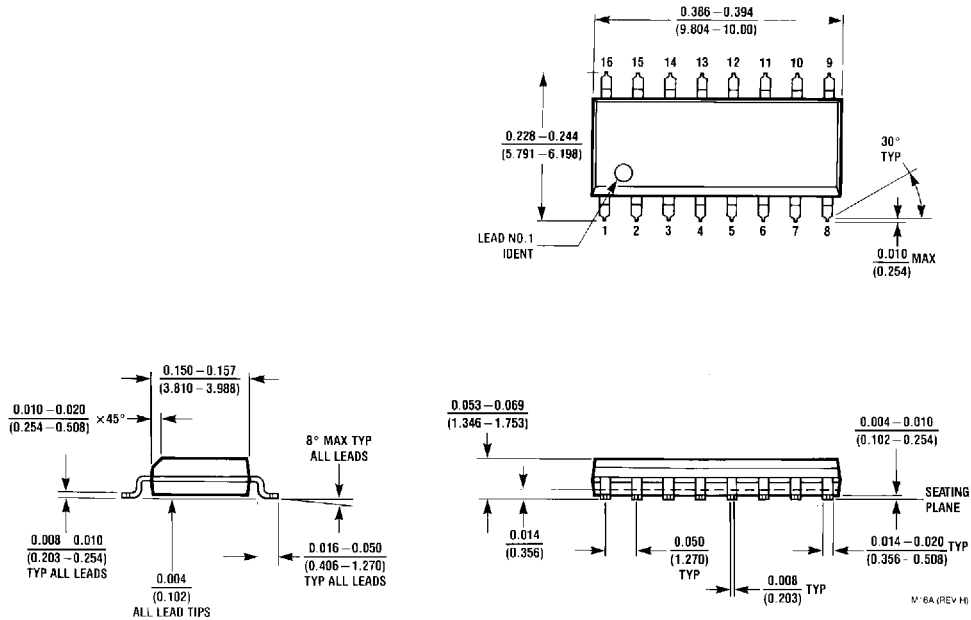

**16-Lead Small Outline Integrated Circuit (SOIC), JEDEC MS-012, 0.150" Narrow Body  
Package Number M16A**

**Physical Dimensions** inches (millimeters) unless otherwise noted (Continued)

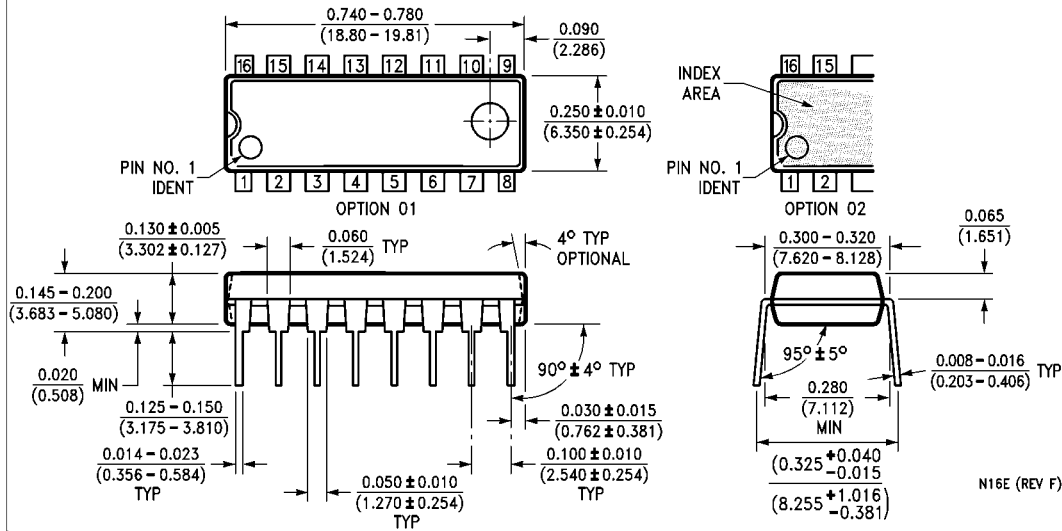

**16-Lead Plastic Dual-In-Line Package (PDIP), JEDEC MS-001, 0.300" Wide  
Package Number N16E**

Fairchild does not assume any responsibility for use of any circuitry described, no circuit patent licenses are implied and Fairchild reserves the right at any time without notice to change said circuitry and specifications.

**LIFE SUPPORT POLICY**

FAIRCHILD'S PRODUCTS ARE NOT AUTHORIZED FOR USE AS CRITICAL COMPONENTS IN LIFE SUPPORT DEVICES OR SYSTEMS WITHOUT THE EXPRESS WRITTEN APPROVAL OF THE PRESIDENT OF FAIRCHILD SEMICONDUCTOR CORPORATION. As used herein:

1. Life support devices or systems are devices or systems which, (a) are intended for surgical implant into the body, or (b) support or sustain life, and (c) whose failure to perform when properly used in accordance with instructions for use provided in the labeling, can be reasonably expected to result in a significant injury to the user.
2. A critical component in any component of a life support device or system whose failure to perform can be reasonably expected to cause the failure of the life support device or system, or to affect its safety or effectiveness.

[www.fairchildsemi.com](http://www.fairchildsemi.com)