

High Speed PWM Controller

PRELIMINARY

FEATURES

- Compatible with Voltage or Current Mode Control Methods
- Practical Operation at Switching Frequencies to 4MHz
- 50ns Propagation Delay to Output
- High Current Complementary Outputs
- Programmable Dead Time and Frequency Oscillator
- Pulse by Pulse Current Limiting
- Latched Overcurrent Comparator with Full Cycle Restart
- Programmable Undervoltage Lockout (UVLO)
- Adjustable Blanking for Leading Edge Noise Tolerance

DESCRIPTION

The UCC3829 is a BiCMOS High Speed PWM Controller IC. It is optimized for high frequency switched mode power supply applications. The IC can be used in both voltage mode and current mode control applications. Care was given to minimizing the propagation delays through the comparators and logic circuitry while maximizing the bandwidth and slew rate of the error amplifier. The oscillator frequency and deadtime can be programmed via two external resistors and a capacitor. The undervoltage lockout threshold can be programmed using an external resistor divider. The current limit and overcurrent threshold can be set externally. The IC is available in push-pull (-1), single ended (-2), or complementary (-3) output configuration.

Fault protection circuitry includes undervoltage detection for the internal bias supply, and overcurrent detection. The fault detection logic sets a latch that ensures full discharge of the soft start capacitor before allowing a restart. While the fault latch is set, the outputs are in a low state. In the event of continuous faults, the soft start capacitor is fully charged before discharging to insure that the fault frequency does not exceed the designed soft start period.

BLOCK DIAGRAM

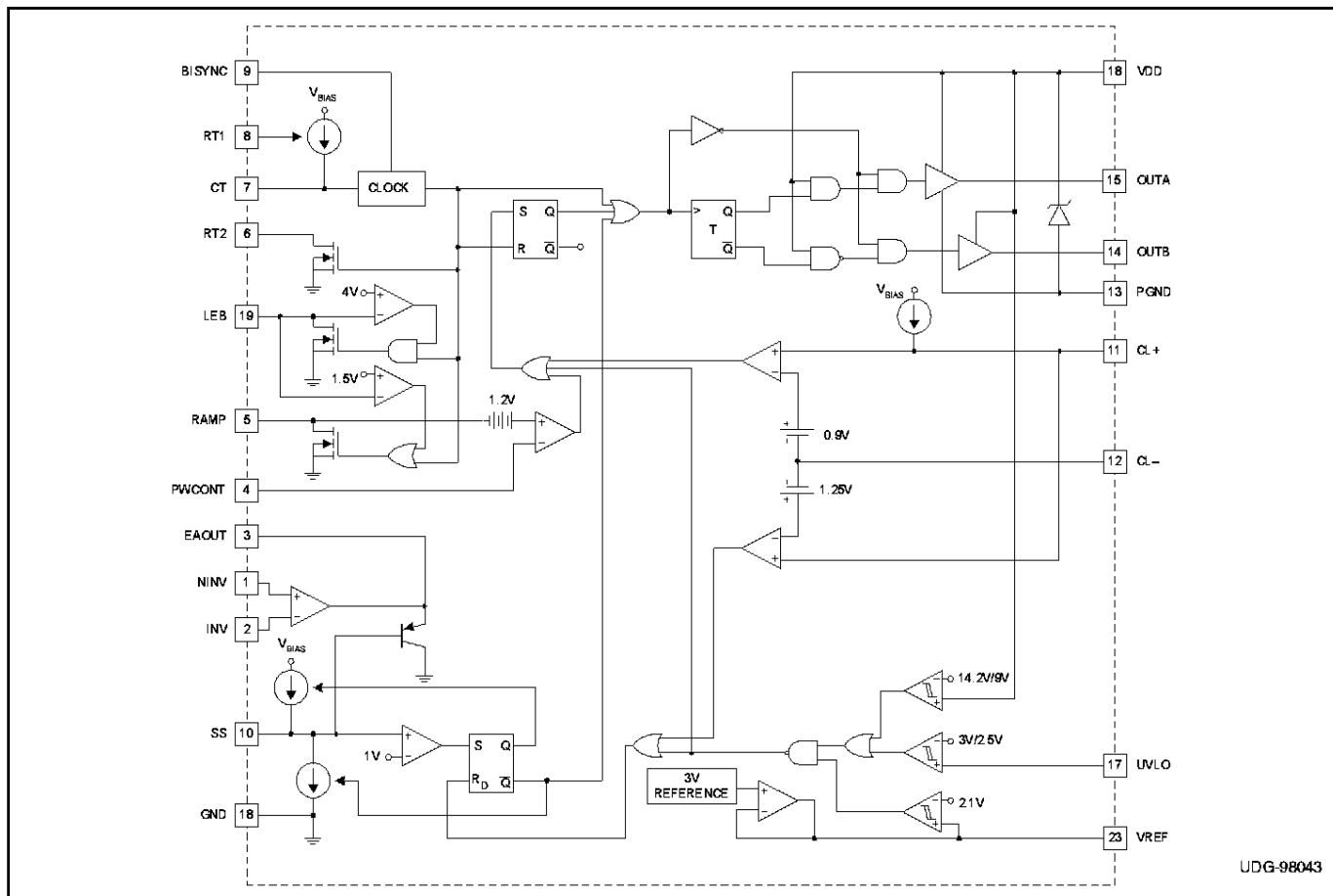

UDG-98043

ABSOLUTE MAXIMUM RATINGS

Supply Voltage	15V
Supply Current	25mA
Output Current (OUTA, OUTB, PGND, VCC)	
DC	0.5A
Pulsed (0.5µsec)	2.2A
PGND	± 0.2V
Analog Inputs	
INV, NINV, RAMP, SS	-0.3 to 7V
CL+, CL-	0.3V to 3V
Error Amplifier Output Current	5mA
Error Amplifier Output Capacitance	20pF
Storage Temperature	-65°C to +150°C
Junction Temperature	-55°C to +150°C
Lead Temperature (Soldering, 10sec.)	+300°C

Unless otherwise indicated, voltages are referenced to GND. Currents are positive into, negative out of the specified terminal. Consult Packaging Section of Databook for thermal limitations and considerations of packages.

PART VERSION TABLE

PART NUMBER	OUTPUT	OUT A/B PHASE	OUTPUT FREQUENCY
UCCX829-1	Push-Pull	180° Out of Phase	F _{CT} /2
UCCX829-2	Dual Single-Ended	In Phase	F _{CT}
UCCX829-3	Non-Overlapping Complimentary	OUTB = $\overline{\text{OUTA}}$	F _{CT}

ORDERING INFORMATION

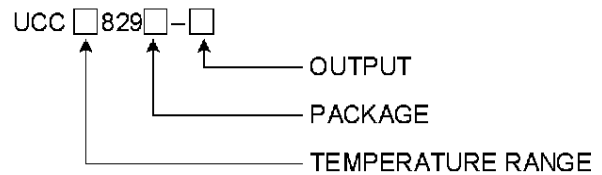

TEMPERATURE & PACKAGE SELECTION GUIDE TABLE

	TEMPERATURE RANGE	AVAILABLE PACKAGES
UCC1829-X	-55°C to +125°C	J
UCC2829-X	-40°C to +85°C	N, DW, Q
UCC3829-X	0°C to +70°C	N, DW, Q

CONNECTION DIAGRAMS

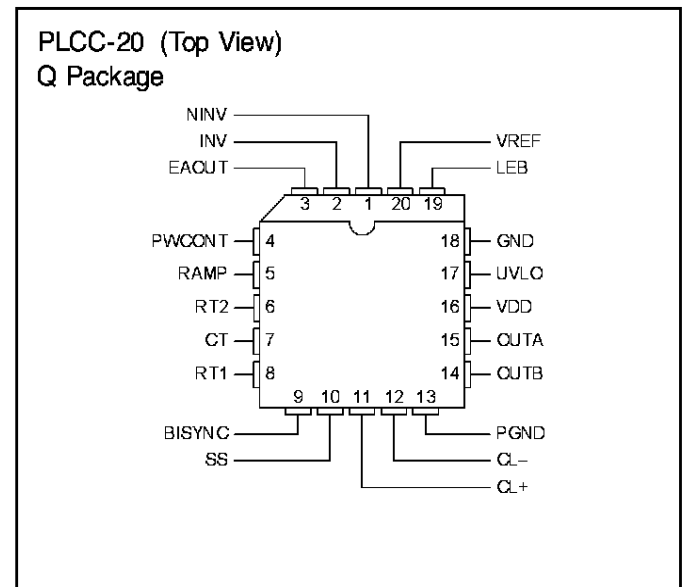
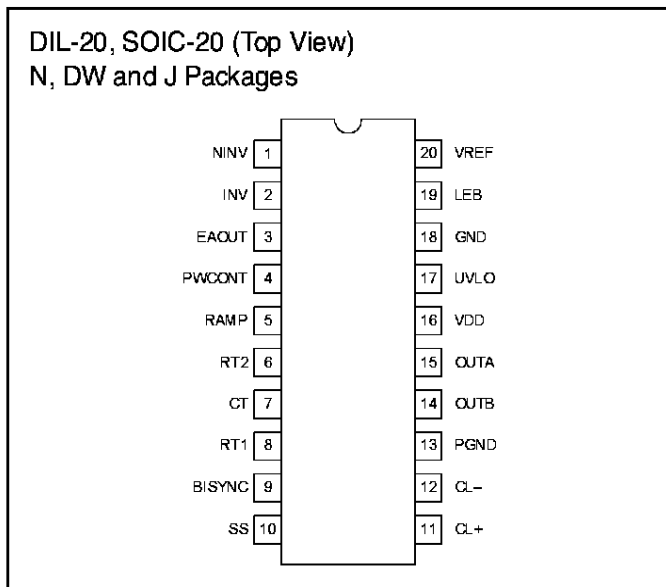

ELECTRICAL CHARACTERISTICS: Unless otherwise specified, RT1 = 34.8kΩ, CT = 470pF, RT2 = 392Ω, VDD = 12V, Over Full Temperature Range and TA = TJ.

PARAMETER	TEST CONDITIONS	MIN	TYP	MAX	UNITS
Reference Section					
Output Voltage	TJ = 25°C, No Load, Output Off	2.97	3	3.03	V
	Over Temperature, No Load, Output Off	2.94		3.06	V
Line Regulation	VDD = 5V to 14.5V, Output Off, No Load, (Note 2)		35	50	mV
Load Regulation	0 < IREF < 5mA		2	10	mV
Total Output Variation	Line, Load, Temperature = 0°C to 70°C, (Note 1)	2.93		3.07	V
	Line, Load, Temperature = -55°C to +125°C, (Note 1)	2.90		3.10	V
Short Circuit Current	VREF = 0	-25			mA
Oscillator Section					
Initial Accuracy	TJ = 25°C	360	400	440	kHz
Total Variation	Line, Temperature (Note 1)	320		480	kHz
Temperature Stability	TMIN < TA < TMAX (Note 1)		5	10	%
Initial Accuracy, 1MHz	RT1 = 25.7k, CT = 150pF, TJ = 25°C, (Note 1)	0.9	1	1.1	MHz
Total Variation, 1MHz	RT1 = 25.7k, CT = 150pF, Line, Temperature (Note 1)	0.8		1.2	MHz
Ramp Peak Voltage		1.8	2	2.2	V
Ramp Valley Voltage			1	1.5	V
Peak To Peak Voltage		0.85	1	1.15	V
BISYNC Output Source Current	VBISYNC = VDD - 0.5V		-2	-1.5	mA
BISYNC Output Sink Current	VBISYNC = 0.5V	60	140		μA
BISYNC Input Threshold		1	1.5	2	V
Error Amplifier Section					
Input Offset Voltage				5	mV
Input Bias Current		-1		1	μA
Input Offset Current				250	nA
Open Loop Gain		70	80		dB
CMRR	1.5V < VCM < 4.5V	75			dB
PSRR	5V < VDD < 14.5V	75			dB
Output Sink Current	VEAOUT = 1V	300	500		μA
Output Source Current	VEAOUT = 4V		-500	-300	μA
Output High Voltage	IEAOUT = -300μA	3	5		V
Output Low Voltage	IEAOUT = 300μA		0.6	1	V
Gain Bandwidth Product	VDD = 12V, TJ = 25°C	5	7		MHz
Slew Rate		1.5	2		V/μs
PWM Comparator Section					
Input Bias Current V(RAMP)		-60		1	μA
Minimum Duty Cycle	400kHz			0	%
Maximum Duty Cycle (UCCX829-1)	400kHz, RT2 Resistor = 200Ω	42.5			%
Maximum Duty Cycle (UCCX829-2, -3)	400kHz, RT2 Resistor = 200Ω	85			%
Delay to Output			50	100	ns
Current Limit Fault Section					
Soft Start Charge Current		-40		-10	μA
Soft Start Complete Threshold	SS Pin (Note 1)		3		V
Restart Discharge Current		10		40	μA

ELECTRICAL CHARACTERISTICS: Unless otherwise specified, RT1 = 34.8kΩ, CT = 470pF, RT2 = 392Ω, VDD = 12V, Over Full Temperature Range and TA = TJ.

PARAMETER	TEST CONDITIONS	MIN	TYP	MAX	UNITS
Restart Threshold		0.8	1	1.2	V
Current Limit Threshold	Relative to CL-	0.8	0.875	1.1	V
Overcurrent Threshold	Relative to CL-	1.1	1.25	1.4	V
Current Limit Delay to Output			50	100	ns
	VDD = 5V		100	400	ns
Output Section (OUTA, OUTB)					
Output Low Saturation	IOUT = 200mA		0.5	1.0	V
Output High Saturation	IOUT = -100mA		0.5	1.0	V
UVLO Output Low Saturation	At 10mA		0.1	0.5	V
Rise Time	CLOAD = 1nF, TJ = 25°C		20	40	ns
Fall Time	CLOAD = 1nF, TJ = 25°C		10	20	ns
Output Source Current	VOUT = 0, TJ = 25°C (Note 1)		-0.75		A
Output Sink Current	VOUT = 12V, TJ = 25°C (Note 1)		1.5		A
Complementary Delay Time (Delay 2) (UCCX829 -3 Only)	(Note 1)	50		150	ns
Undervoltage Lockout					
UVLO Enable Threshold		2.9	3	3.1	V
UVLO Hysteresis		0.3	0.5	0.7	V
VDD UVLO Enable Threshold		13.5		14.5	V
VDD UVLO Hysteresis		3.5		7	V
Supply Section					
VDD Range	No Load	4.25		14.5	V
Startup Current	VUVLO = 2V, VDD = 13.5V		3	5	mA
IDD	400kHz, No Load		8	12	mA

Note 1: Guaranteed by design. Not 100% tested in production.

Note 2: Refer to Figure 1.

TYPICAL CHARACTERISTIC CURVES

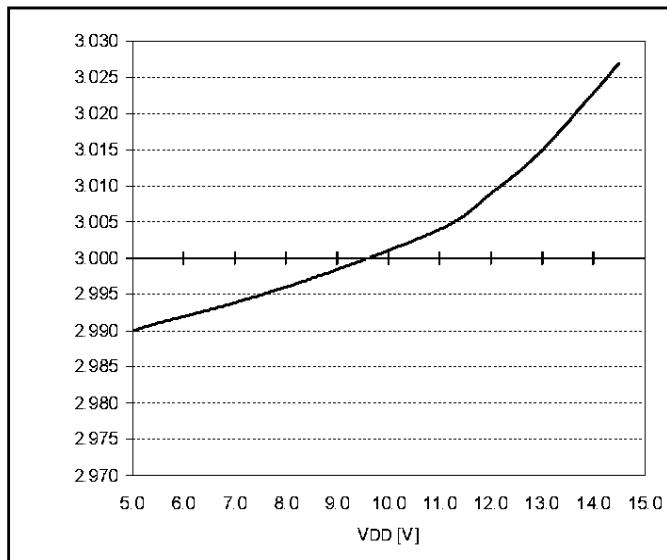

Figure 1. Reference vs. VDD

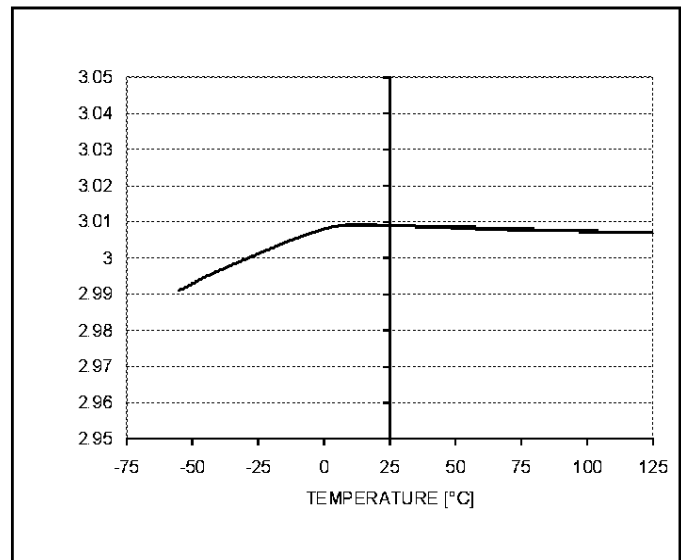

Figure 2. Reference vs. Temperature

PIN DESCRIPTIONS

BISYNC: Combination clock output/sync input pin. The clock signal can be viewed on this pin. If BISYNC is connected to BISYNC of other UCC3829 chips, all the oscillators will run at the highest of all the chips frequencies. The BISYNC pin has a weak pull down and a strong pull up.

CL+: Current sense input for current limiting. The CL+ and CL- pins are used for current sensing. CL+ is the current signal while CL- is the kelvin return for the sensing function.

CL-: Current sense input kelvin common.

CT: Oscillator timing capacitor. A capacitor connected between CT and GND is charged by a current source controlled by RT1. The capacitor is discharged through a resistor connected between CT and RT2.

EAOUT: Error amplifier output. This output is normally connected directly to the PWCONT pin. It can also be connected to PWCONT through a resistor divider attenuation network to allow more swing of the error amplifier output. A maximum capacitive load of 20pF with respect to ground must be observed to insure stability of the error amplifier.

GND: Logic and analog ground. The GND pin should be used for all signal level returns, except the current sense inputs.

INV: Error amplifier inverting input.

LEB: Leading edge blanking programming pin. Connecting a resistor between VREF and LEB and a capacitor between LEB and GND will program a leading edge blanking time according to the RC of the resistor/capacitor combination. Connecting the LEB pin to VDD disables the Leading Edge Blanking function.

NINV: Error amplifier non-inverting input.

OUTA: Output A. The OUTA pin will pull down with approximately 1.5A and pull up with approximately 0.75A. The UCC3829-1 implements push-pull outputs with OUTA and OUTB active on alternating clock cycles. The UCC3829-2 implements OUTA and OUTB being in phase. The UCC3829 -3 implements OUTA and OUTB to be non-overlapping complementary outputs during the same clock cycle. The output frequency of the UCC3829-1 is half that of the UCC3829-2 and UCC3829 -3.

OUTB: Output B. The OUTB pin will pull down with approximately 1.5A and pull up with approximately 0.75A. The UCC3829-1 implements push-pull outputs with OUTA and OUTB active on alternating clock cycles. The

UCC3829-2 implements OUTA and OUTB being in phase. The UCC3829 -3 implements OUTA and OUTB to be non-overlapping complementary outputs during the same clock cycle. The output frequency of the UCC3829-1 is half that of the UCC3829-2 and UCC3829 -3.

PGND: Power ground return. The PGND pin should be used as the return for the VDD bypass capacitor and the current sense kelvin CL-.

PWCONT: Pulse width control input. This is connected to the PWM comparator inverting input.

RAMP: Ramp input . This is connected to the PWM comparator non-inverting input through a level shifting voltage of approximately 1.25V.

RT1: Oscillator charging current programming resistor. A 1V reference at this pin generates a current through a resistor connected between RT1 and GND. This current is mirrored and ratioed to charge the timing capacitor connected to pin CT.

RT2: Oscillator discharge time programming resistor. The oscillator (and output) dead time can be programmed via this pin. The discharge of the timing capacitor CT is determined by an RC discharge using a resistor connected between RT2 and CT.

SS: Soft start capacitor pin. A capacitor connected to SS determines the time the IC takes to soft start. The nominal SS pin pull up and pull down current is 20μA. The soft start time delay is approximately calculated as:

$$\frac{CSS \cdot 3V}{20\mu A}$$

when charging from 0V. After the SS pin reaches the SS complete threshold of 3V, another SS cycle can be started. The restart time is approximately:

$$\frac{2 \cdot CSS \cdot 3V}{20\mu A}$$

UVLO: Undervoltage lockout programming pin. Connecting a resistor divider between VDD, UVLO, and GND sets a VDD value at which the UCC3829 chip will be enabled. When the voltage on the UVLO pin reaches 3V, the chip is enabled. When the voltage on UVLO falls below 2.5V, the chip is disabled.

VDD: Voltage supply to IC. VDD is clamped at 14V.

VREF: Voltage reference output and filtering. The voltage reference output appears on the VREF pin. It is buffered to drive approximately 5mA and short circuit protected at approximately 25mA. A bypass capacitor of at least 0.1μF must be connected from VREF to ground.

APPLICATION INFORMATION

Functional Programmability

Various features of the UCC3829 are user programmable. RT1 and RT2 allow independent programming for oscillator rise and fall times within the normal operational range of the chip. A new feature allows the user to program the voltage that flags an undervoltage fault. The default value of 14V for chip turn-on is selected by tying the UVLO pin to ground. If the user wants to select startup voltage then a resistive divider should be tied from Vdd to ground, with the centerpoint tied to the UVLO pin. The chip will be enabled when the UVLO pin reaches 3V, and disabled below 2.5V. Leading edge blanking can also be optimized to eliminate turn-on noise when current mode control is used or disabled when desired.

Oscillator

The oscillator uses an external capacitor CT and two external resistors RT1 and RT2 to generate the clock frequency and dead time. A precise reference voltage is placed across resistor RT1 to generate a current reference. The current is then mirrored and used to charge the capacitor CT from VVALLEY. When a "peak" threshold is reached, an on chip MOSFET connects the RT2 pin to GND, discharging CT to a "valley" threshold through an external resistor RT2. The CT waveform has a linear ramp shape while charging and an exponential (RC) slope while discharging. The slope of the charging ramp is set by the CT, RT1 combination and the slope of the discharging ramp is set by the values of CT and RT2.

The approximate equation for the rising edge (TR) of the CT waveform (maximum on-time period) is:

$$T_R = C_T R_{T1} \left(\frac{V_{PEAK} - V_{VALLEY}}{9.3} \right)$$

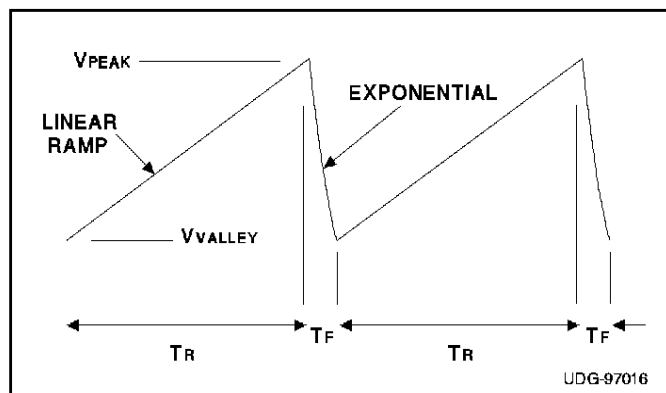

Figure 3.

The approximate equation for the falling edge (TF) of the CT waveform (deadtime period) is:

$$T_F = R_{T2} C_T \ln \left(\frac{V_{PEAK} - \frac{9.3 R_{T2}}{R_{T1}}}{V_{VALLEY} - \frac{9.3 R_{T2}}{R_{T1}}} \right)$$

Assuming that:

$$\frac{9.3 R_{T2}}{R_{T1}} \ll V_{PEAK} \text{ and } \frac{9.3 R_{T2}}{R_{T1}} \ll V_{VALLEY}$$

We get a simplified equation:

$$T_F = R_{T2} C_T \ln \left(\frac{V_{PEAK}}{V_{VALLEY}} \right)$$

Given a maximum on-time and frequency and assuming an initial value for either RT2 or CT, you can use the TF equation to calculate the other. Once you have a value for CT, you can calculate RT1 using the TR equation.

Error Amplifier Section

The Error Amplifier has both inputs and the output brought out to pins NINV, INV, and EAOUT. The output of the error amplifier can be connected to the inverting input of the PWM comparator via the pin PWCONT. This allows inserting attenuation which enables using the full output swing of the error amplifier. The output of the error amplifier is forced to follow the soft start waveform during soft start.

PWM and Output Section

The non-inverted input of the PWM comparator is connected to RAMP. The RAMP can be connected to either the CT capacitor for voltage mode control, to the current sense resistor for current mode control, or to a feed forward capacitor for input voltage feed forward control. The CT waveform can be coupled to RAMP to provide slope compensation in the current mode case. The MOSFET switch connected to RAMP provides for the discharge of the feedforward capacitor. There is a short time constant (3ns) filter across the inputs of the PWM comparator to reduce noise.

The output of the PWM comparator feeds an OR gate which, together with several other fault signals, sets the PWM latch. The latch is in turn reset on every dead time period of the clock waveform. The output of the PWM latch is OR'ed with the clock and the output of the Fault Latch (described below) to feed into the pulse steering Toggle Flip-Flop (TFF). The resulting signal is then steered according to the output configuration of UCC3829. The clock output becomes the deadtime between the outputs.

Output Timing Configurations

The timing diagram shows the major differences between the UCC3829-1, -2 and -3 parts. The output of the UCC3829-1 is a push-pull configuration with outputs A and B 180° out of phase and with an output frequency that is half of the CT's waveform.

The UCC3829-2 produces dual outputs that are in phase and can be used in situations that require high current drive for single ended designs. A 0.5Ω resistor should be added in series with each output before they are connected together. The output pulse frequency is equal to the CT waveform frequency in this case.

The output drive in the UCC3829-3 has a non-overlapping complementary configuration. During each clock cycle Output A produces an output pulse, followed by a short delay, and then Output B produces an output pulse. The short delay between Output A and Output B pulses is t_{cd} , the complementary delay time. This ensures that the outputs are never high simultaneously.

TIMING DIAGRAMS

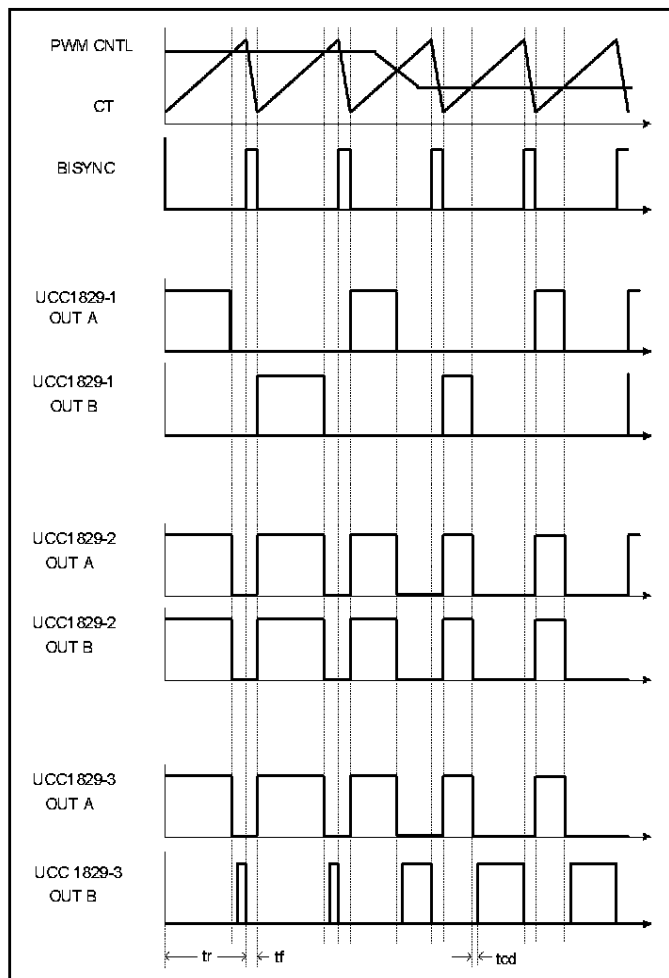

Leading Edge Blanking Section

The Leading Edge Blanking circuit provides a means to insert a blanking period at the beginning of the cycle, providing noise pulse elimination for current mode control applications. This feature is similar to that of the UC3825 and UC3823A/B controllers. When enabled, an external resistor is connected from LEB to VREF. An external capacitor is connected from LEB to either VREF or GND. During the deadtime, LEB is pulled to GND. At the beginning of the cycle, the pin is released and the capacitor charges through the resistor toward VREF. At the threshold $V_{REF}/2$, a comparator senses the voltage and LEB is removed. The leading edge blanking function can be disabled by connecting LEB to VDD ($> V_{REF}$). Leading edge blanking is performed by the same MOSFET switch connected to RAMP that is used for voltage feed forward operation.

Current Timing and Protection

The current limit and overcurrent functions are accomplished using the pins CL+ and CL-. These two pins provide for differential current level sensing, with the trip points referenced to CL-, rather than GND. The current limit function provides a pulse by pulse current limiting, whereas the overcurrent function is considered a fault condition and initiates a fault logic soft start cycle.

The UCC3829 utilizes differential current sensing and separate logic and power ground pins to eliminate some of the noise issues of using current mode control. Devices with only one common ground pin for all stated functions required the combination of power gate drive current and low-level sensing currents in a common trace. Since the current signal needed for control is embedded in the power gate drive current, it is not enough just to separate logic and power ground pins. Differential sensing in UCC3829 referenced to the negative rail allows the cleanest method of sensing current for use in a peak current mode controlled power supply utilizing resistive sensing. Current limiting is done on a cycle by cycle basis when the typical threshold of 0.875V is reached. If the fault level of 1.25V is reached a soft start cycle is initiated. Internal circuitry insures that soft start cycles are completed so that fault currents can be controlled.

Fault Logic Section

The fault logic detects and handles various fault conditions in the system. The output of the overcurrent comparator is logically ORed with the output combination of the undervoltage detection circuit ORed with the output of the precision reference voltage VREF is compared to a level (approx-

mately 3 V_{BE} voltages) to determine if the reference is alive. The undervoltage circuit either uses a user programmed level with a 16% hysteresis or an on threshold equal to the V_{DD} clamp voltage and an off threshold of 9V.

Once a fault occurs, a soft start cycle takes place. A fault sets the fault latch. The Q output of the fault latch sets the RS delay latch and turns on the $20\mu A$ soft start discharge current sink. The Q output of the fault latch is gated, however, by the output of the Ss complete comparator. This insures that a SS cycle cannot start before the previous one has finished. The soft start capacitor then is discharged to 1V which is sensed by the RS delay comparator. The fault latch is then reset. This in turn resets the RS delay latch and turns off the $20\mu A$ current

sink and turns on a $20\mu A$ current source to charge the Ss capacitor.

The under voltage detection is set to a default value of 14V turn on (V_{DD} clamp active value) and 9V turn off when the UVLO pin is tied to GND. This default configuration can be overridden by connecting a resistor divider between V_{DD} and GND to the UVLO pin. The hysteresis for the user set threshold is 16%.

During undervoltage lockout, the self biasing outputs are held "OFF" to prevent accidental turn-on of the power switches.

Supply Section

The incoming voltage supply V_{DD} is clamped by a shunt V_{DD} Clamp circuit at 14V.

TYPICAL APPLICATIONS

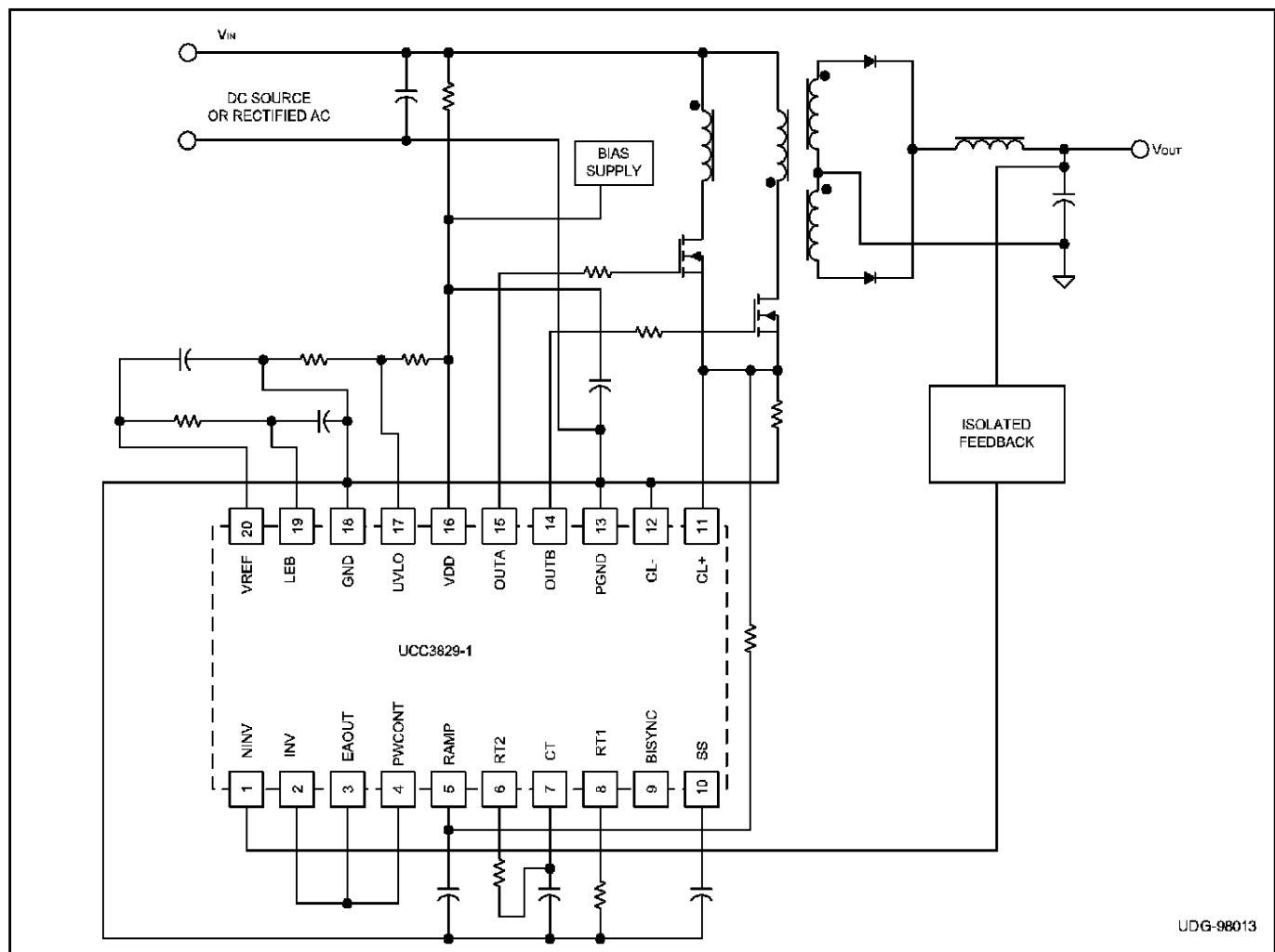
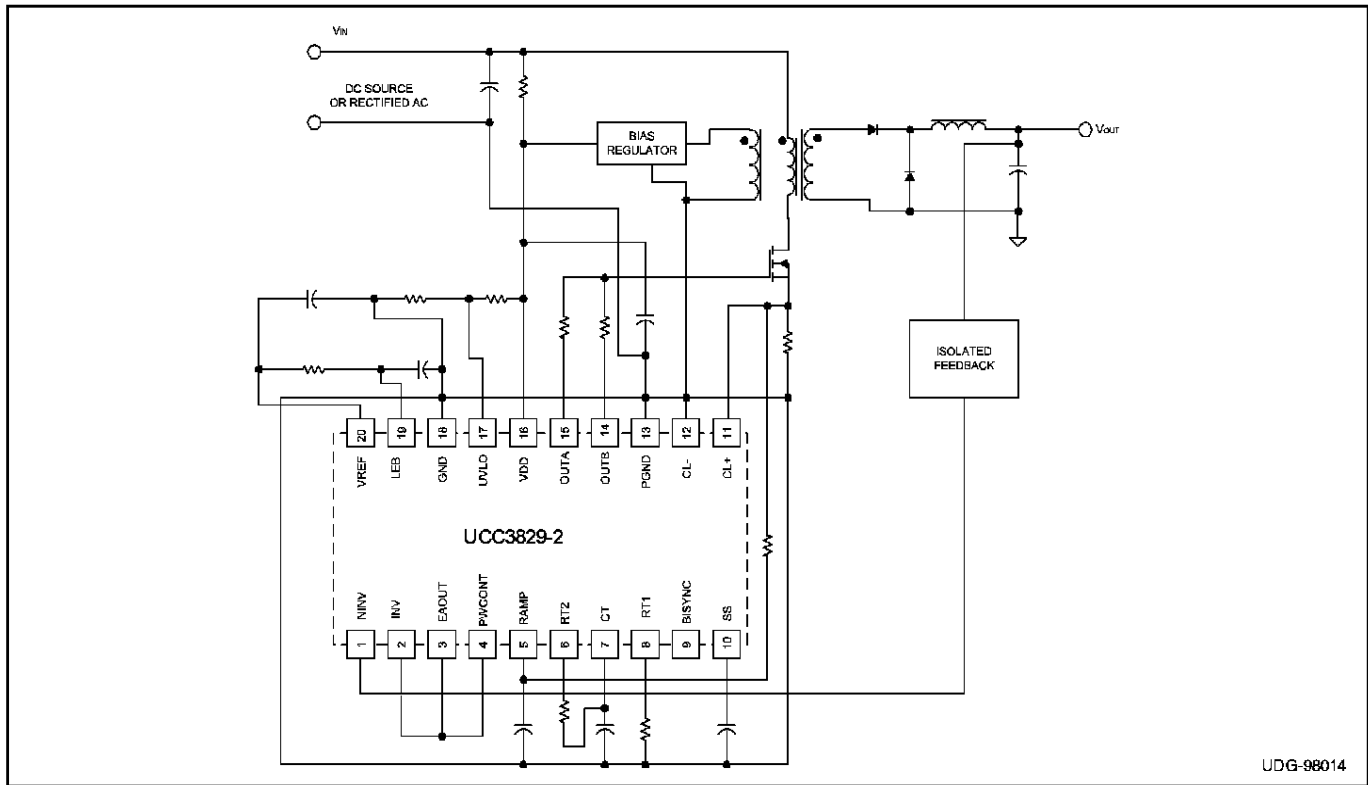

Figure 4. Push-Pull Converter Using UCC3829-1

TYPICAL APPLICATIONS (cont.)



UDG-98014

Figure 5. Single Ended Converter with High Power Gate Drive Using UCC3829-2

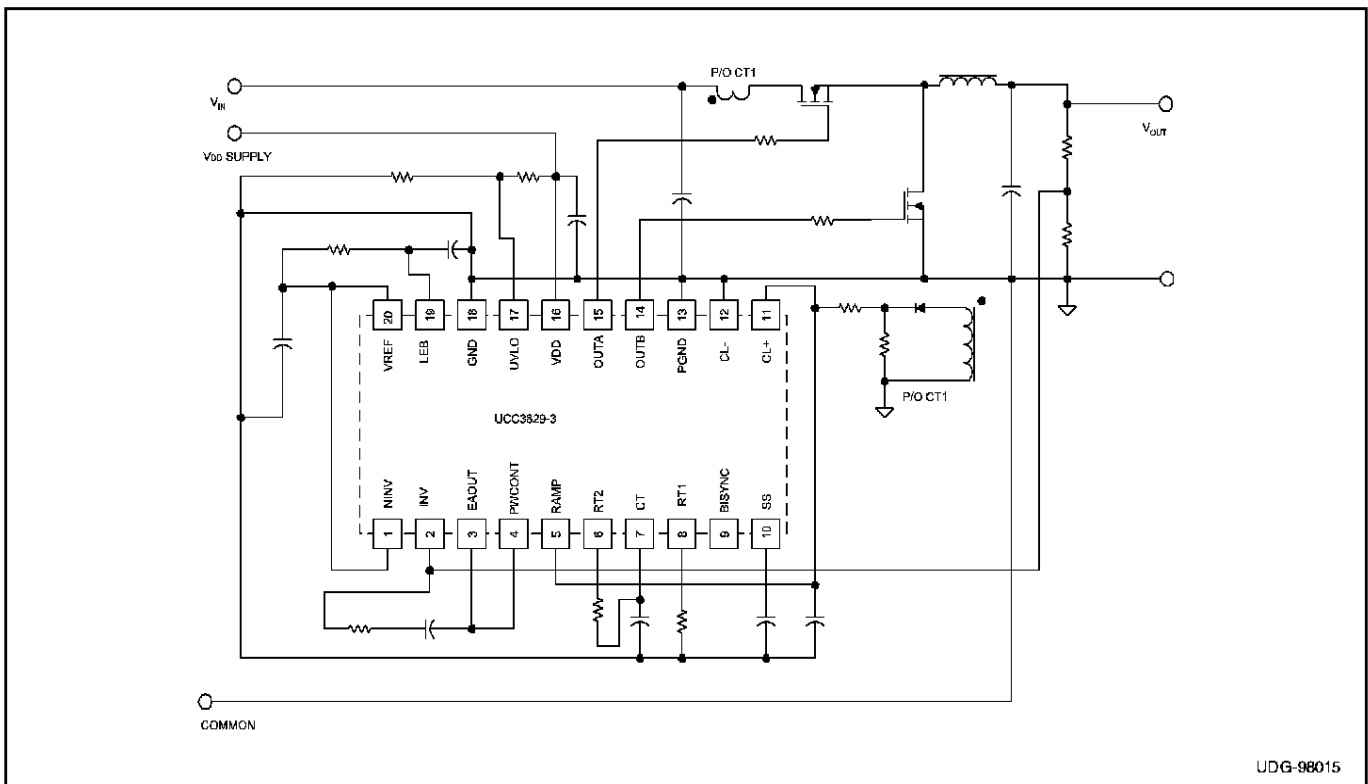

UDG-98015

Figure 6. Synchronous Rectifier Controller Using UCC3829-3