

SN54HCT658, SN54HCT659, SN74HCT658, SN74HCT659 OCTAL BUS TRANSCEIVERS WITH PARITY

D2839, MARCH 1984—REVISED SEPTEMBER 1987

- Inputs are TTL-Voltage Compatible
- Bus Transceivers with Inverting Outputs ('HCT658) or True Outputs ('HCT659)
- Generates a Parity Bit for A Bus and B Bus
- Easily Cascadable
- Internal Active Pull-Ups and Pull-Downs
- High-Current 3-State Outputs Can Drive Up to 15 LSTTL Loads
- Package Options Include Plastic "Small Outline" Packages, Ceramic Chip Carriers, and Standard Plastic and Ceramic 300-mil DIPs
- Dependable Texas Instruments Quality and Reliability

SN54HCT658, SN54HCT659 . . . JT PACKAGE
SN74HCT658, SN74HCT659 . . . DW-OR NT PACKAGE
(TOP VIEW)

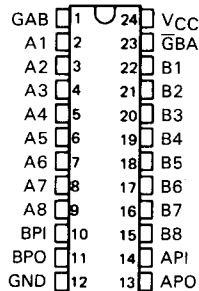

SN54HCT658, SN54HCT659 . . . FK PACKAGE
(TOP VIEW)

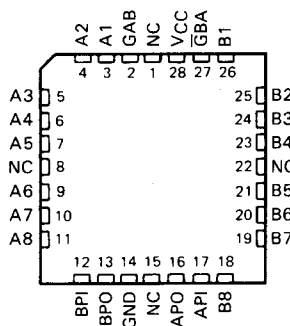

NC—No internal connection

description

These octal bus transceivers are designed for asynchronous, bidirectional communication between data buses. The devices transmit data from the A Bus to the B Bus or from the B Bus to the A Bus, depending on the levels at the direction control inputs, GAB and GBA. These devices also generate parity outputs, APO and BPO, which reflect the number of high levels at the A Bus and B Bus, respectively, taking into account the parity inputs API and BPI.

The bidirectional I/O ports feature active circuits on the input stage that, when the output shared by that pin is disabled, will maintain the input in the last state taken by the output. This state will be maintained until changed by activity on the bus. The advantage of this arrangement is that when all outputs on the bus are disabled, the inputs will be prevented from floating, resulting in minimum power dissipation and minimum susceptibility to noise. This eliminates any need for external pull-up or pull-down resistors. The parity inputs API and BPI have similar circuits. For further information, see Typical Application Data in 'HCT658 series data sheet.

The SN54HCT658 and SN54HCT659 are characterized for operation over the full military temperature range of -55°C to 125°C. The SN74HCT658 and SN74HCT659 are characterized for operation from -40°C to 85°C.

2

HCMOS Devices

PRODUCTION DATA documents contain information current as of publication date. Products conform to specifications per the terms of Texas Instruments standard warranty. Production processing does not necessarily include testing of all parameters.



POST OFFICE BOX 655012 • DALLAS, TEXAS 75265

Copyright © 1984, Texas Instruments Incorporated

2-609

SN54HCT658, SN54HCT659, SN74HCT658, SN74HCT659 OCTAL BUS TRANSCEIVERS WITH PARITY

FUNCTION TABLE

CONTROL INPUTS		NUMBER OF HIGH INPUTS ON A BUS AND API	NUMBER OF HIGH INPUTS ON B BUS AND BPI	OUTPUTS		OPERATION	
$\bar{G}BA$	GAB			APO	BPO	HCT658	HCT659
L	L	X	0, 2, 4, 6, 8	Z	H	\bar{B} Data to A Bus	B Data to A Bus
		X	1, 3, 5, 7, 9	Z	L		
H	H	0, 2, 4, 6, 8	X	H	Z	\bar{A} Data to B Bus	A Data to B Bus
		1, 3, 5, 7, 9	X	L	Z		
H	L	X	X	Z	Z	Isolation	Isolation
L	H	X	0, 2, 4, 6, 8		H	\bar{B} Data to A Bus, \bar{A} Data to B Bus	B Data to A Bus, A Data to B Bus
		X	1, 3, 5, 7, 9		L		
		0, 2, 4, 6, 8	X		H		
		1, 3, 5, 7, 9	X		L		

2

HCMOS Devices

logic symbols †

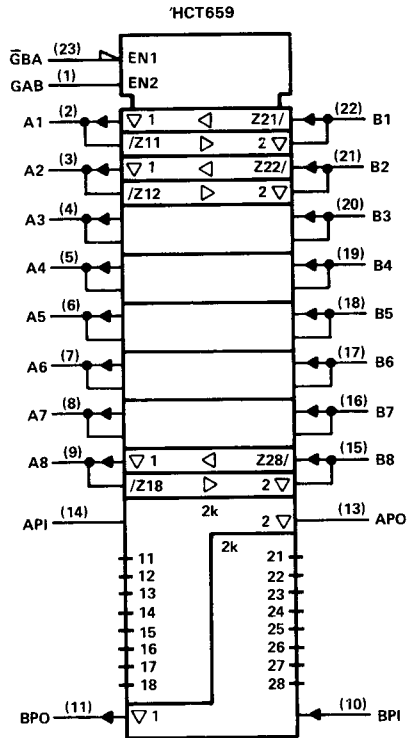
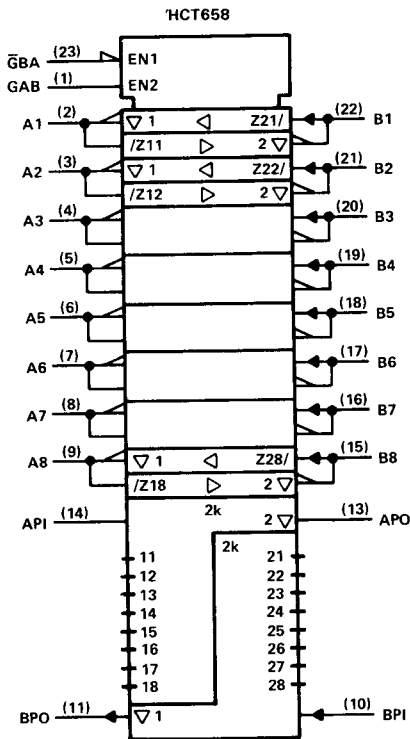

† These symbols are in accordance with ANSI/IEEE Std 91-1984 and IEC Publication 617-12.

Pin numbers shown are for DW, JT, and NT packages.

SN54HCT658, SN54HCT659, SN74HCT658, SN74HCT659 OCTAL BUS TRANSCEIVERS WITH PARITY

logic diagram (positive logic)

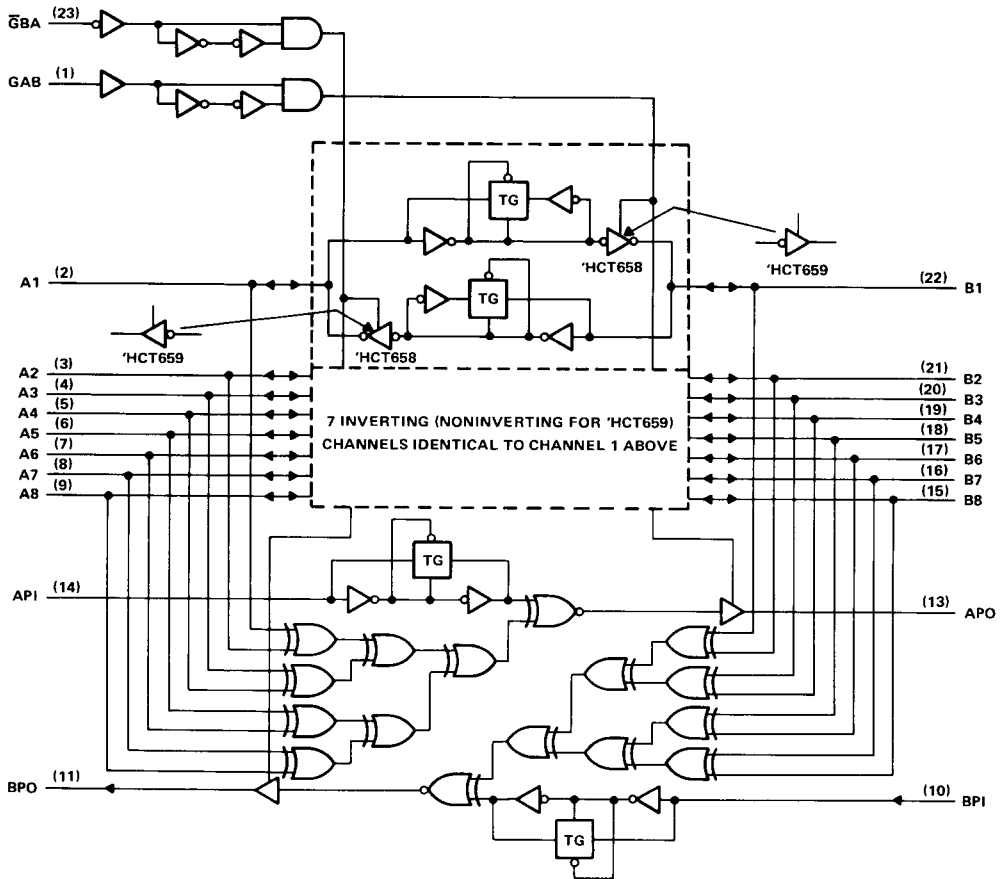

Pin numbers shown are for DW, JT, and NT packages.

absolute maximum ratings over operating free-air temperature†

Supply voltage, V_{CC}	-0.5 V to 7 V
Input clamp current, I_{IK} ($V_I < 0$ or $V_I > V_{CC}$)	± 20 mA
Output clamp current, I_{OK} ($V_O < 0$ or $V_O > V_{CC}$)	± 20 mA
Continuous output current, I_O ($V_O = 0$ to V_{CC})	± 35 mA
Continuous current through V_{CC} or GND pins	± 70 mA
Lead temperature 1,6 mm (1/16 in) from case for 60 s: FK or JT package	300°C
Lead temperature 1,6 mm (1/16 in) from case for 10 s: DW or NT package	260°C
Storage temperature range	-65°C to 150°C

† Stresses beyond those listed under "absolute maximum ratings" may cause permanent damage to the device. These are stress ratings only, and functional operation of the device at these or any other conditions beyond those indicated under "recommended operating conditions" is not implied. Exposure to absolute-maximum-rated conditions for extended periods may affect device reliability.

SN54HCT658, SN54HCT659, SN74HCT658, SN74HCT659 OCTAL BUS TRANSCEIVERS WITH PARITY

recommended operating conditions

		SN54HCT658 SN54HCT659			SN74HCT658 SN74HCT659			UNIT
		MIN	NOM	MAX	MIN	NOM	MAX	
V _{CC}	Supply voltage	4.5	5	5.5	4.5	5	5.5	V
V _{IH}	High-level input voltage	V _{CC} = 4.5 V to 5.5 V			2			V
V _{IL}	Low-level input voltage	V _{CC} = 4.5 V to 5.5 V			0	0.8		V
V _I	Input voltage	0	V _{CC}		0	V _{CC}		V
V _O	Output voltage	0	V _{CC}		0	V _{CC}		V
t _t	Input transition (rise and fall) times	0	500		0	500		ns
T _A	Operating free-air temperature	-55		125	-40		85	°C

2

HCMOS Devices

electrical characteristics over recommended operating free-air temperature range (unless otherwise noted)

PARAMETER		TEST CONDITIONS	V _{CC}	T _A = 25°C			SN54HCT658 SN54HCT659		SN74HCT658 SN74HCT659		UNIT
				MIN	TYP	MAX	MIN	MAX	MIN	MAX	
V _{OH}		V _I = V _{IH} or V _{IL} , I _{OH} = -20 μA	4.5 V	4.4	4.499		4.4		4.4		V
V _{OH}	All outputs except APO & BPO	V _I = V _{IH} or V _{IL} , I _{OH} = -6 mA	4.5 V	3.98	4.30		3.7		3.84		
	APO and BPO	V _I = V _{IH} or V _{IL} , I _{OH} = -4 mA	4.5 V	3.98	4.30		3.7		3.84		
V _{OL}		V _I = V _{IH} or V _{IL} , I _{OL} = 20 μA	4.5 V	0.001 0.1		0.1		0.1		V	
V _{OL}	All outputs except APO & BPO	V _I = V _{IH} or V _{IL} , I _{OL} = 6 mA	4.5 V	0.17 0.26		0.4		0.33			
	APO and BPO	V _I = V _{IH} or V _{IL} , I _{OL} = 4 mA	4.5 V	0.17 0.26		0.4		0.33			
I _I	GAB, GBA, API OR BPI	V _I = V _{CC} or 0	5.5 V	±0.1 ±100		±1000		±1000		nA	
I _{OZ}	A or B	V _O = V _{CC} or 0, V _I = V _{IH} or V _{IL}	5.5 V	±0.01 ±0.5		±10		±5		μA	
I _{CC}		V _I = V _{CC} or 0, I _O = 0	5.5 V	8		160		80		μA	
ΔI _{CC} [†]		One input at 0.5 or 2.4 V Other inputs at 0 V or V _{CC}	5.5 V	1.4 2.4		3		2.9		mA	
C _i [‡]			4.5 to 5.5 V	3 10		10		10		pF	

[†]This is the increase in supply current for each input that is at one of the specified TTL voltage levels rather than 0 V or V_{CC}.

[‡]This parameter, C_i, does not apply to I/O ports.

SN54HCT658, SN74HCT658
OCTAL BUS TRANSCEIVERS WITH PARITY

switching characteristics over recommended operating free-air temperature range (unless otherwise noted), $C_L = 50$ pF (see Note 1)

PARAMETER	FROM (INPUT)	TO (OUTPUT)	V _{CC}	T _A = 25°C			SN54HCT658		SN74HCT658		UNIT
				MIN	TYP	MAX	MIN	MAX	MIN	MAX	
t _{pd}	A or B	B or A	4.5 V	15	30	45	38	ns			
			5.5 V	13	27	41	34				
t _{pd}	A or B	APO or BPO	4.5 V	23	46	69	58	ns			
			5.5 V	20	41	62	52				
t _{pd}	API or BPI	APO or BPO	4.5 V	15	31	47	39	ns			
			5.5 V	14	28	42	35				
t _{en}	GAB or $\overline{G}BA$	APO or BPO	4.5 V	24	47	71	59	ns			
			5.5 V	21	42	64	53				
t _{dis}	GAB or $\overline{G}BA$	APO or BPO	4.5 V	24	47	71	59	ns			
			5.5 V	21	42	64	53				
t _t		Any	4.5 V	8	12	18	15	ns			
			5.5 V	7	11	16	14				

C _{pd}	Power dissipation capacitance	No load, T _A = 25°C	62 pF typ
-----------------	-------------------------------	--------------------------------	-----------

switching characteristics over recommended operating free-air temperature range (unless otherwise noted), $C_L = 150$ pF (see Note 1)

PARAMETER	FROM (INPUT)	TO (OUTPUT)	V _{CC}	T _A = 25°C			SN54HCT658		SN74HCT658		UNIT
				MIN	TYP	MAX	MIN	MAX	MIN	MAX	
t _{pd}	A or B	B or A	4.5 V	23	47	71	59	ns			
			5.5 V	21	42	64	53				
t _{pd}	A or B	APO or BPO	4.5 V	31	63	95	79	ns			
			5.5 V	28	56	85	71				
t _{pd}	API or BPI	APO or BPO	4.5 V	24	48	73	60	ns			
			5.5 V	21	43	65	54				
t _{en}	GAB or $\overline{G}BA$	APO or BPO	4.5 V	32	64	97	80	ns			
			5.5 V	28	57	87	72				
t _t		Any	4.5 V	17	42	63	53	ns			
			5.5 V	14	38	57	48				

NOTE 1: Load circuits and voltage waveforms are shown in Section 1.

For typical application data and a description of the unique input structure, see the 'HC658 series data sheet.

2
HCMOS Devices

SN54HCT659, SN74HCT659
OCTAL BUS TRANSCEIVERS WITH PARITY

switching characteristics over recommended operating free-air temperature range (unless otherwise noted), $C_L = 50$ pF (see Note 1)

PARAMETER	FROM (INPUT)	TO (OUTPUT)	V _{CC}	T _A = 25°C			SN54HCT659		SN74HCT659		UNIT
				MIN	TYP	MAX	MIN	MAX	MIN	MAX	
t _{pd}	A or B	B or A	4.5 V	14	28		61		50	ns	
			5.5 V	12	25		42		35		
t _{pd}	A or B	APO or BPO	4.5 V	23	46		69		58	ns	
			5.5 V	20	41		62		52		
t _{pd}	API or BPI	APO or BPO	4.5 V	15	31		47		39	ns	
			5.5 V	14	28		42		35		
t _{en}	GAB or \overline{G} BA	APO or BPO	4.5 V	24	47		71		59	ns	
			5.5 V	21	42		64		53		
t _{dis}	GAB or \overline{G} BA	APO or BPO	4.5 V	24	47		71		59	ns	
			5.5 V	21	42		64		53		
t _t		Any	4.5 V	8	12		18		15	ns	
			5.5 V	7	11		16		14		

C _{pd}	Power dissipation capacitance	No load, T _A = 25°C	62 pF typ
-----------------	-------------------------------	--------------------------------	-----------

switching characteristics over recommended operating free-air temperature range (unless otherwise noted), $C_L = 150$ pF (see Note 1)

PARAMETER	FROM (INPUT)	TO (OUTPUT)	V _{CC}	T _A = 25°C			SN54HCT659		SN74HCT659		UNIT
				MIN	TYP	MAX	MIN	MAX	MIN	MAX	
t _{pd}	A or B	B or A	4.5 V		23	45		84		67	ns
			5.5 V		20	40		68		56	
t _{pd}	A or B	APO or BPO	4.5 V		32	63		95		79	ns
			5.5 V		28	56		85		71	
t _{pd}	API or BPI	APO or BPO	4.5 V		24	48		73		60	ns
			5.5 V		21	43		65		54	
t _{en}	GAB or \overline{G} BA	APO or BPO	4.5 V		32	64		97		80	ns
			5.5 V		29	57		87		72	
t _t		Any	4.5 V		21	42		63		53	ns
			5.5 V		19	38		57		48	

NOTE 1: Load circuits and voltage waveforms are shown in Section 1.

For typical application data and a description of the unique input structure, see the 'HC658 series data sheet.

2

HCMOS Devices