

High Efficiency, High Power Factor Preregulator

FEATURES

- Programmable PWM Frequency Foldback for Higher Efficiency at Light Loads
- Leading Edge PWM for Reduced Output Capacitor Ripple Current
- Controls Boost PWM to Near Unity Power Factor
- World Wide Operation without Switches
- Accurate Power Limiting
- Synchronizable Oscillator
- 100µA Startup Supply Current
- Low Power BCDMOS
- 12V to 18V Operation

DESCRIPTION

The UCC3858 provides all of the control functions necessary for active power factor corrected preregulators which require high efficiency at low power operation. The controller achieves near unity power factor by shaping the AC input line current waveform to correspond to the AC input line voltage using average current mode control.

The operation of the UCC3858 closely resembles that of previously designed Unitrode PFC parts with additional features to allow higher efficiency boost converter operation at light loads. This is accomplished by linearly scaling back the PWM frequency when the output of the voltage error amplifier drops below a predetermined user programmable level indicating a light load condition. The frequency is scaled back by reducing the charging current for the CT ramp (in proportion to the output power), and increasing the dead time. There is also an instantaneous reset input to pull the IC out of foldback mode quickly when the load comes back up.

The PWM technique used in the UCC3858 is leading edge modulation. When combined with the more conventional trailing edge modulation on the downstream converter, this scheme offers the benefit of reduced ripple current on the bulk storage capacitor. The oscillator is designed for easy synchronization to the downstream converter. A simple synchronization scheme can be implemented by connecting the PWM output of the downstream converter to the SYNC pin.

(continued)

BLOCK DIAGRAM

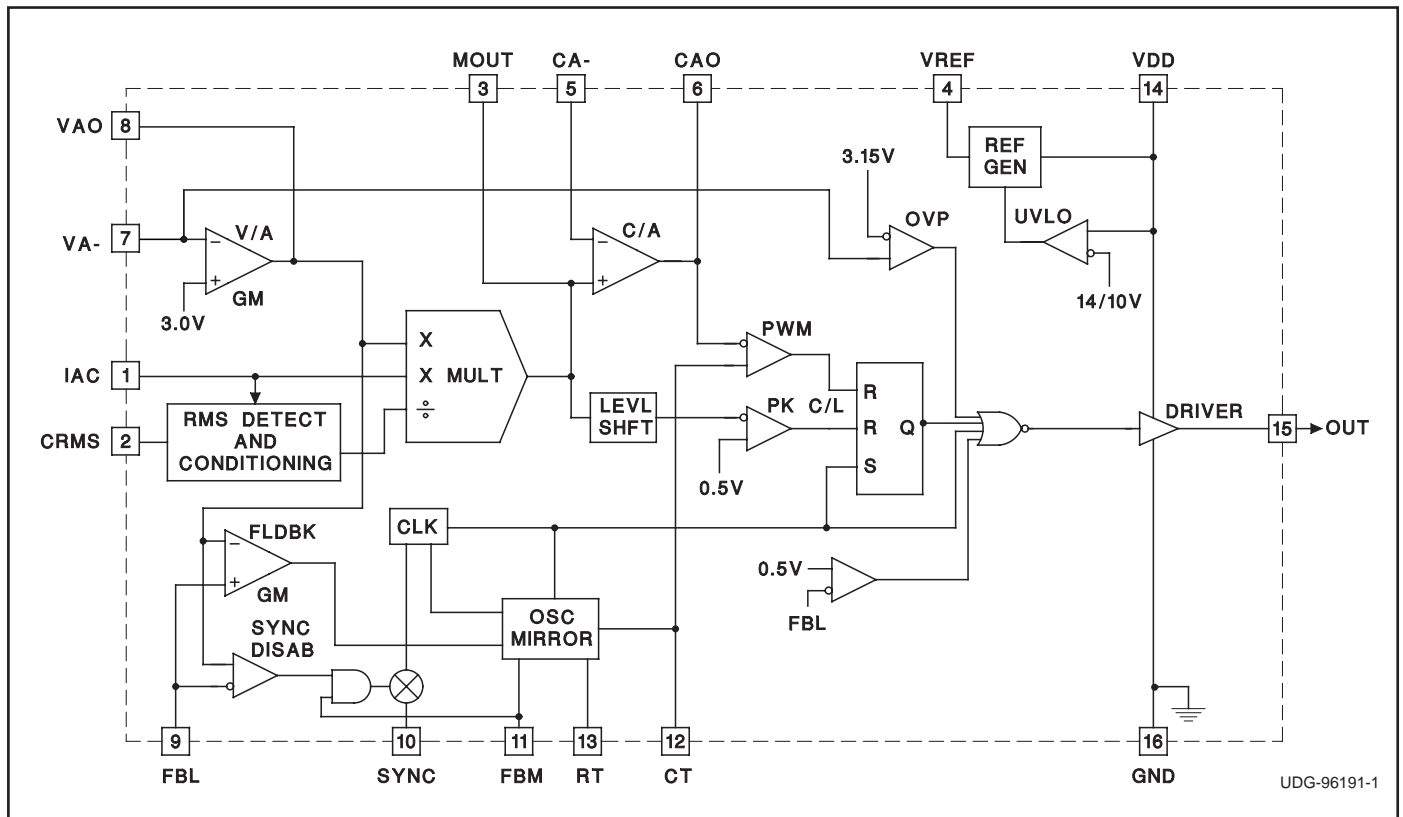

ABSOLUTE MAXIMUM RATINGS

Supply Voltage V_{DD}	18V
Gate Drive Current	
Continuous	0.2A
Pulsed	500mA
Input Current IAC	200mA
Power Dissipation	1W
Storage Temperature	-65°C to +150°C
Junction Temperature	-55°C to +150°C
Lead Temperature (Soldering, 10 Sec.)	+300°C
Analog Inputs	
Maximum Forced Voltage	-0.3V to 11V

Unless otherwise indicated, voltages are reference to ground and currents are positive into, negative out of the specified terminal. Pulsed is defined as a less than 10% duty cycle with a maximum duration of 500ns. Consult Packaging Section of Databook for thermal limitations and considerations of packages.

CONNECTION DIAGRAM

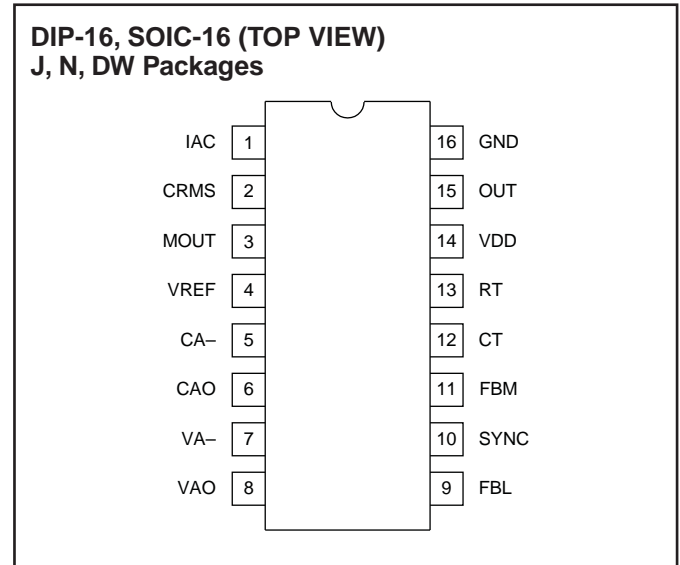

DESCRIPTION (cont.)

Controller improvements include an onboard peak detector for the input line RMS voltage, an integrated overcurrent shutdown, overvoltage shutdown and significantly lower quiescent operating current. The peak detector eliminates an external 2-pole low pass filter for RMS detection. This simplifies the converter design as well as providing an approximate 6X improvement in input line transient response. The current signal is extracted from the current error amplifier input to provide a cycle-by-cycle peak current limit. Low startup and operating currents which are achieved through the use of

Unitrode's BCDMOS process simplify the bootstrap supply design as well as minimize losses in the control circuit. A transconductance voltage error amplifier allows output voltage sensing for internal overvoltage protection.

Additional features include: undervoltage lockout for reliable off-line startup, a precision 7.5V reference, and a precision RMS detection and signal conditioning circuit. Chip shutdown can be attained by bringing the FBL pin below 0.5V.

ELECTRICAL CHARACTERISTICS: Unless otherwise stated, these specifications apply for $T_A = 0^\circ\text{C}$ to 70°C for the UCC3858, -40°C to $+85^\circ\text{C}$ for the UCC2858, and -55°C to $+150^\circ\text{C}$ for the UCC1858, $V_{VDD} = 12\text{V}$, $R_T = 24\text{k}$, $C_T = 330\text{pF}$, $R_{FBM} = 96\text{k}$, $I_{IAC} = 100\mu\text{A}$, $T_A = T_J$.

PARAMETER	TEST CONDITIONS	MIN	TYP	MAX	UNITS
Overall					
Supply Current, Off	$V_{CAO}, V_{VAO} = 0\text{V}$, $V_{DD} = \text{UVLO} - 0.3\text{V}$		100	250	μA
Supply Current, On	$\text{FBL} = 0\text{V}$	2	3.5	5	mA
VDD Turn-On Threshold		12	13.5	15.5	V
VDD Turn-Off Threshold			10		V
UVLO Hysteresis		3.2	3.5	3.8	V
Voltage Amplifier					
Input Voltage	$T_A = 25^\circ\text{C}$	2.95	3	3.05	V
Over Voltage Protection	Volts Above V_{A-} Input Voltage	0.12	0.14	0.16	V
V_{A-} Bias Current			-0.5	-1	μA
Open Loop Gain	$V_{OUT} = 2\text{V}$ to 5V	45	50		dB
VAO High	Load = $-25\mu\text{A}$	5.7	6	6.3	V
VAO Low	Load = $25\mu\text{A}$		0.3	0.5	V
Output Source Current	$V_{VA-} = 2.8\text{V}$			-50	μA
Output Sink Current	$V_{VA-} = 3.2\text{V}$	50			μA
Transconductance	$I_{OUT} = \pm 50\mu\text{A}$	400	600	1000	μS

ELECTRICAL CHARACTERISTICS: Unless otherwise stated, these specifications apply for $T_A = 0^\circ\text{C}$ to 70°C for the UCC3858, -40°C to $+85^\circ\text{C}$ for the UCC2858, and -55°C to $+150^\circ\text{C}$ for the UCC1858, $V_{DD} = 12\text{V}$, $R_T = 24\text{k}$, $C_T = 330\text{pF}$, $R_{FBM} = 96\text{k}$, $I_{AC} = 100\mu\text{A}$, $T_A = T_J$.

PARAMETER	TEST CONDITIONS	MIN	TYP	MAX	UNITS
Current Amplifier					
Input Offset Voltage	$V_{CM} = 0\text{V}$, $V_{CAO} = 3\text{V}$	-3	0	3	mV
Input Bias Current	$V_{CM} = 0\text{V}$, $V_{CAO} = 3\text{V}$	-6.5	-5		μA
Input Offset Current	$V_{CM} = 0\text{V}$, $V_{CAO} = 3\text{V}$	-0.5	0.0	0.5	μA
Open Loop Gain	$V_{CM} = 0\text{V}$, $V_{CAO} = 2\text{V}$ to 5V	80	90		dB
CMRR	$V_{CM} = 0\text{V}$ to 1.5V , $V_{CAO} = 3\text{V}$	65	80		dB
CAO High	$V_{CA-} = 0\text{V}$, $V_{MOUT} = 1\text{V}$, $I_L = -50\mu\text{A}$	6.5	7	7.5	V
CAO Low	$V_{CA-} = 1\text{V}$, $V_{MOUT} = 0\text{V}$, $I_L = 1\text{mA}$		0.2	0.3	V
Maximum Output Source Current		-130	-150		μA
Voltage Reference					
Output Voltage	$I_{REF} = 0\text{mA}$, $T_A = 25^\circ\text{C}$	7.313	7.5	7.688	V
	Over Temperature, UCC3858	7.294	7.5	7.707	V
	Over Temperature, UCC2858, UCC1858	7.239	7.5	7.762	V
Load Regulation	$I_{REF} = 0\text{mA}$ to 2mA		3	5	mV
Line Regulation	$V_{DD} = 12\text{V}$ to 16V		30		mV
Short Circuit Current	$V_{REF} = 0\text{V}$		35	50	mA
Oscillator					
Initial Accuracy	$T_A = 25^\circ\text{C}$	90	100	110	kHz
Voltage Stability	$V_{DD} = 12\text{V}$ to 16V			1	%
Total Variation	Line, Temperature	80		120	kHz
Ramp Amplitude (p-p)	Oscillator Free Running, $V_{AO} = 5.5\text{V}$	3.3	3.5	3.7	V
Ramp Peak Voltage	Oscillator Free Running, $V_{AO} = 5.5\text{V}$	4.4	4.6	4.8	V
Peak Current Limit					
PKLMT Threshold Voltage	$(V_{CA-}) - V_{MOUT}$	350	450	550	mV
PKLMT Hysteresis			100	200	mV
PKLMT Propagation Delay			1		μs
Multiplier Section					
High Line, Low Power	$I_{AC} = 100\mu\text{A}$, $V_{CRMS} = 3.5\text{V}$, $V_{AOUT} = 1.25\text{V}$		1		μA
High Line, High Power	$I_{AC} = 100\mu\text{A}$, $V_{CRMS} = 3.5\text{V}$, $V_{AOUT} = 5.5\text{V}$		15		μA
Low Line, Low Power	$I_{AC} = 20\mu\text{A}$, $V_{CRMS} = 0.75\text{V}$, $V_{AOUT} = 1.25\text{V}$		4		μA
Low Line, High Power	$I_{AC} = 20\mu\text{A}$, $V_{CRMS} = 0.75\text{V}$, $V_{AOUT} = 5.5\text{V}$		64		μA
IAC Limited	$I_{AC} = 20\mu\text{A}$, $V_{CRMS} = 0.4\text{V}$, $V_{AOUT} = 5.5\text{V}$		64		μA
Gain Constant	$I_{AC} = 100\mu\text{A}$, $V_{CRMS} = 3.5\text{V}$, $V_{AOUT} = 5.5\text{V}$		2.5		1/V
Zero Current	$I_{AC} = 20\mu\text{A}$, $V_{CRMS} = 0.75\text{V}$, $V_{AOUT} = 5.5\text{V}$ (Note 1)		0		μA
	$I_{AC} = 100\mu\text{A}$, $V_{CRMS} = 3.5\text{V}$, $V_{AOUT} = 5.5\text{V}$ (Note 1)		0		μA
Power Limit ($V_{CRMS} \cdot I_{MO}$)	$I_{AC} = 20\mu\text{A}$, $V_{CRMS} = 0.75\text{V}$, $V_{AOUT} = 5.5\text{V}$		45		μW
PWM Frequency Foldback					
FBL Input Current		-500	-100		nA
FBL Output Disable			0.5		V
Foldback Minimum Frequency	$R_{FBM} = 100\text{k}$		25	30	kHz
FBM Foldback Override			1.5	1.75	V

ELECTRICAL CHARACTERISTICS: Unless otherwise stated, these specifications apply for $T_A = 0^\circ\text{C}$ to 70°C for the UCC3858, -40°C to $+85^\circ\text{C}$ for the UCC2858, and -55°C to $+150^\circ\text{C}$ for the UCC1858, $V_{\text{VDD}} = 12\text{V}$, $R_T = 24\text{k}$, $C_T = 330\text{pF}$, $R_{\text{FBM}} = 96\text{k}$, $I_{\text{IAC}} = 100\mu\text{A}$, $T_A = T_J$.

PARAMETER	TEST CONDITIONS	MIN	TYP	MAX	UNITS
Gate Driver					
Pull Up Resistance	$I_{\text{OUT}} = 100\text{mA}$		7		Ω
Pull Down Resistance	$I_{\text{OUT}} = -100\text{mA}$		3.5		Ω
Output Rise Time	$C_{\text{LOAD}} = 1\text{nF}$, $R_S = 10\Omega$		25		ns
Output Fall Time	$C_{\text{LOAD}} = 1\text{nF}$, $R_S = 10\Omega$		20		ns

Note1: M_{OUT} current with contributions from CA+ and peak limit level shift subtracted out.

PIN DESCRIPTIONS

CA–: (Current Amplifier Inverting Input) This input and the non-inverting input MOUT remain functional down to GND.

CAO: (Current Amplifier Output) Output of a wide bandwidth amplifier that senses line current and commands the pulse width modulator (PWM) to force the correct current. This output can swing close to GND, allowing the PWM to force zero duty cycle when necessary.

CRMS: (RMS Measurement Capacitor) A capacitor connected between CRMS and GND enables averaging of the AC line voltage over a half cycle. IAC current is internally mirrored to provide charging current for CRMS.

CT: (Oscillator Timing Capacitor) A capacitor from CT to GND will set the free-running PWM oscillator frequency according to:

$$f = \frac{0.814}{R_T \cdot C_T}$$

FBL: (Frequency Foldback Level Select) Selects the level of the voltage error amplifier output at which frequency foldback begins. A chip shutdown can be attained by bringing the foldback level pin to below 0.5V.

FBM: (Minimum Frequency Reference) A resistor between this pin and VREF is used to set the minimum frequency during foldback mode. Once the value of R_T and C_T are determined, use

$$R_{\text{FBM}} = \frac{0.857}{C_T \cdot f_{\text{MIN}}} - R_T$$

to find the value of R_{FBM} which will set the minimum foldback frequency to f_{MIN} . This pin also incorporates a foldback override which enables the part to return quickly to normal operating mode when the load comes back up. To override foldback mode, force this pin below 1.5V with an open collector.

GND: (Ground) All voltages measured with respect to ground. VDD and VREF should be bypassed directly to GND with a 0.1 μF or larger ceramic capacitor. The timing

capacitor discharge current also returns to this pin, so the lead from CT to GND should be as short and direct as possible.

IAC: (Input AC Current) This input to the analog multiplier is a current. The multiplier is tailored for very low distortion from this current input (I_{IAC}) to MOUT. Requires some bypassing to GND for noise filtering (<470pF).

MOUT: (Multiplier Output) The output of the analog multiplier and the non-inverting input of the current amplifier are connected together at MOUT. As the multiplier output is a current, this is a high impedance input so the amplifier can be configured as a differential amplifier to reject ground noise. The voltage at this pin is also used to implement peak current limiting.

OUT: (Gate Drive Output) The output of the PWM is a totem pole MOSFET gate driver. A series gate resistor of at least 5 Ω is recommended to prevent interaction between the gate impedance and the output driver that might cause the gate drive to overshoot excessively.

RT: (Oscillator Timing Resistor) A resistor from RT to GND is used to program oscillator discharge current.

SYNC: (Oscillator Synchronization Input) Allows the PFC to be synchronized to a trailing edge modulator in the DC-DC stage. A synchronization pulse can be generated from the positive output edge of the downstream regulator and applied to this pin. The internal clock is reset (charged up) on the rising edge of the SYNC input.

VA–: (Voltage Amplifier Inverting Input) This pin is normally connected to the boost converter output through a divider network. It also is an input to the overvoltage comparator where by the output is terminated if this pin's voltage exceeds 3.15V.

VAO: (Voltage Amplifier Output) Output of the transconductance amplifier that regulates output voltage. The voltage amplifier output is internally limited to approximately 6V for power limiting. It is also used to determine the frequency foldback mode. Compensation network is connected from this pin to GND.

PIN DESCRIPTIONS (cont.)

VDD: (Positive Supply Voltage) Connect to a stable source of at least 20mA between 13V and 17V for normal operation. Bypass VDD directly to GND to absorb supply current spikes required to charge external MOSFET gate capacitance. To prevent inadequate gate drive signals, the output devices will be inhibited unless V_{VDD} exceeds the upper undervoltage lockout voltage threshold and remains above the lower threshold.

VREF: (Reference Voltage) VREF is the output of an accurate 7.5V voltage reference. This output is capable of delivering 10mA to peripheral circuitry and is internally short circuit current limited. VREF is disabled and will remain at 0V when V_{VDD} is low. Bypass VREF to GND with a 0.1 μ F or larger ceramic capacitor for best stability.

APPLICATION INFORMATION

The UCC3858 is designed to optimize the implementation of power factor corrected boost converters in low to medium power applications where light load efficiency is critical. While basic configuration of the UCC3858 is similar to the industry standard UC3854 series controllers, several distinguishing features have been added. A typical application circuit is shown along with a diagram showing how the UCC3858 can be used with the downstream converter to achieve optimum performance.

Chip Bias Supply and Startup

The UCC3858 is implemented using Unitrode's BCDMOS process allowing minimal startup (60 μ A typical) and operating (3.5mA typical) supply currents. This results in significantly lower power consumption in the trickle charge resistor used to startup the IC, increasing the system efficiency at light loads. Lower supply currents, coupled with the wide undervoltage lockout hysteresis (13.75V on, 10V off) provide the opportunity to operate both stages from the same startup and bootstrap supply as shown in the typical application drawing.

Oscillator and Frequency Foldback at Light Loads

The oscillator of the UCC3858 is set up to operate either synchronously with the downstream converter or as a stand alone oscillator. A simplified block diagram of the oscillator and associated circuitry is shown in Fig. 2 and the related waveforms are shown in Fig. 3a - 3c. A rising edge at the SYNC pin initiates the clock cycle by charging up the CT pin with a nominal internal current of I_{CHnom} ($=19 \cdot I_{DIS}$). Once the high threshold of the ramp (4.5V) is crossed, the internal latch is set and the CT pin starts discharging at a rate ($I_{DIS}=3/R_T$) set by the resistor on the RT pin. In the absence of a SYNC pulse, C_T discharges all the way to the ramp low threshold (1V) and that sets the free running frequency of the oscillator as given by equation 1. In applications where synchronization is used, the R_T , C_T values should be chosen so that the free running frequency is always lower than the synchronization frequency.

$$f = \frac{19}{20} \cdot \frac{3}{3.5} \cdot \frac{1}{R_T \cdot C_T} \quad (1)$$

When VAO falls below the threshold level set by FBL, the oscillator goes into frequency foldback mode and disables synchronization. The frequency foldback is achieved by reducing the oscillator charging current as the power level (and VAO voltage) falls. As shown in Fig. 2, the difference between VAO and FBL regulates current I_{Csub} which subtracts the current available for charging C_T . The effective charge current into the capacitor is given by ($I_{CHnom} - I_{Csub}$). To avoid converter operation in the low frequency range (e.g. audio), the charge current should not be allowed to go very low. Minimum frequency of the controller is programmed by the current I_{MIN} flowing into pin FBM which sets the minimum charging current. The value of R_{FBM} to set the desired minimum frequency is given by:

$$R_{FBM} = \frac{3}{3.5} \cdot \frac{1}{f_{MIN} \cdot C_T} - R_T \quad (2)$$

Fig. 4 shows the characteristic curves for the frequency foldback. When the converter comes out of the low power mode, the time taken to restore normal mode operation (return to nominal or synchronized frequency operation) must be minimized. Given that the voltage error amplifier response is very slow in PFC circuits, the VAO pin change is not the best indicator of change in load conditions. UCC3858 provides a solution where the normal mode can be restored instantaneously when FBM is pulled below 1.5V. A typical interface would involve the output of the error amplifier of the downstream converter (with proper buffering and filtering) driving an npn switch that pulls FBM down to GND. The buffer and filter should ensure that the switch is turned on only when the error amplifier of downstream converter is saturated high for a preset duration indicating a droop in output voltage from increased load. The FBM input can also be permanently pulled low to disable the frequency foldback mode completely, while still using the other features of UCC3858. FBL pin also acts as a chip disable input when it is brought below 0.5V.

APPLICATION INFORMATION (cont.)

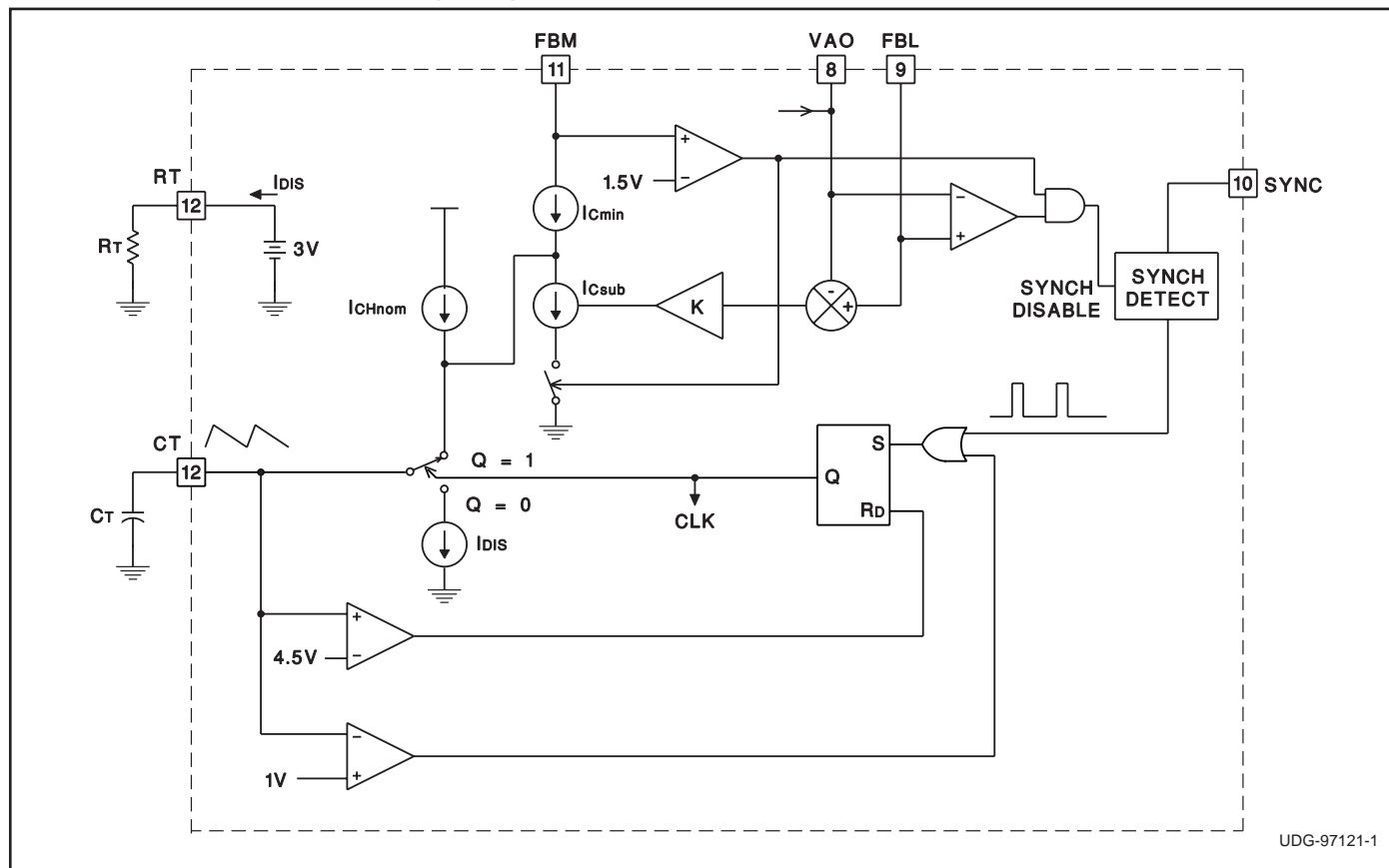

Figure 2. Oscillator block diagram.

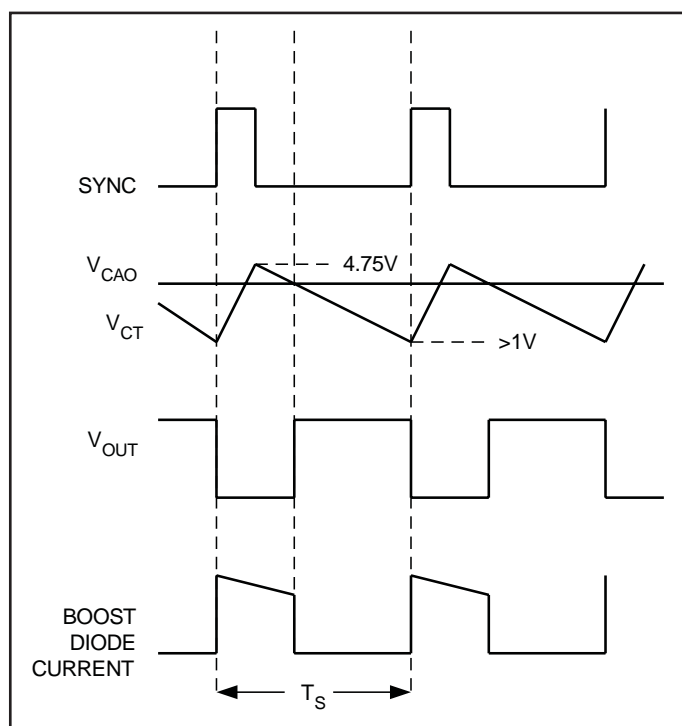

Figure 3a. Oscillator timing waveforms synchronized to buck (DC/DC) PWM.

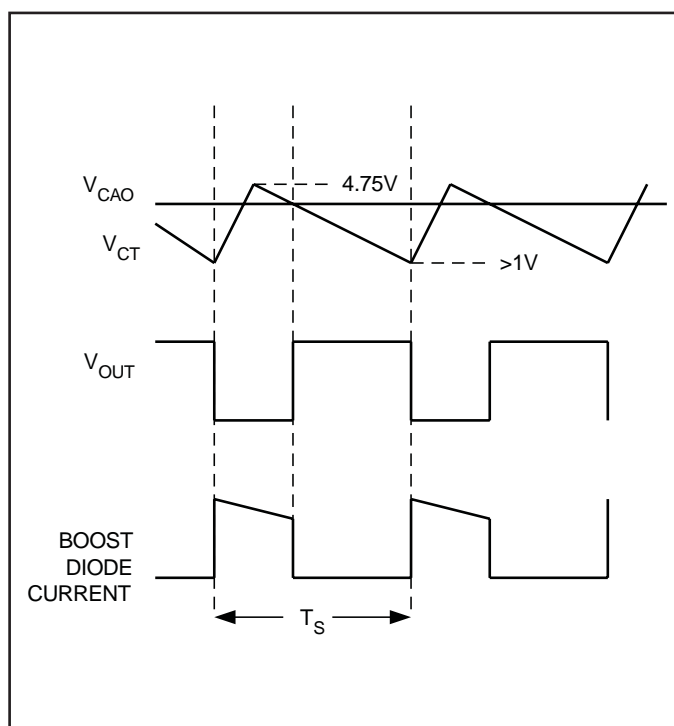

Figure 3b. Oscillator timing waveforms stand alone operation.

APPLICATION INFORMATION (cont.)

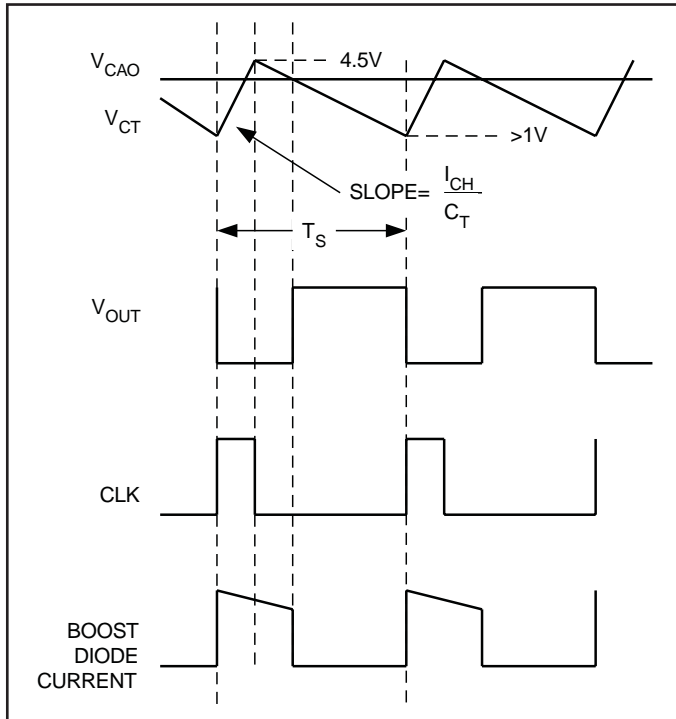

Figure 3c. Frequency foldback mode.

Capacitor Ripple Reduction

For a power system where the PFC boost converter is followed by a DC-DC converter stage, there are benefits to synchronizing the two converters. In addition to the usual advantages such as noise reduction and stability, proper synchronization can significantly reduce the ripple currents in the boost circuit's output capacitor. Fig. 5 helps illustrate the impact of proper synchronization by showing a PFC boost converter together with the simplified input stage of a forward converter. The capacitor current during a single switching cycle depends on the status of the switches Q1 and Q2 and is shown in Fig. 6. It can be seen that with a synchronization scheme that maintains conventional trailing edge modulation on both converters, the capacitor current ripple is highest. The greatest ripple current cancellation is attained when the overlap of Q1 off-time and Q2 on-time is maximized. One method of achieving this is to synchronize the turn-on of the boost diode (D1) with the turn-on of Q2. This approach implies that the boost converter's leading edge is pulse width modulated while the forward converter is modulated with traditional trailing edge PWM. The UCC3858 is designed as a leading edge modulator with easy synchronization to the downstream converter to facilitate this advantage. Table 1 compares the $I_{CB_{rms}}$ for D1/Q2 synchronization as offered by UCC3858 vs. the $I_{CB_{rms}}$ for the other extreme of synchronizing the turn-on of Q1 and Q2 for a 200W power system with a V_{BST} of 385V.

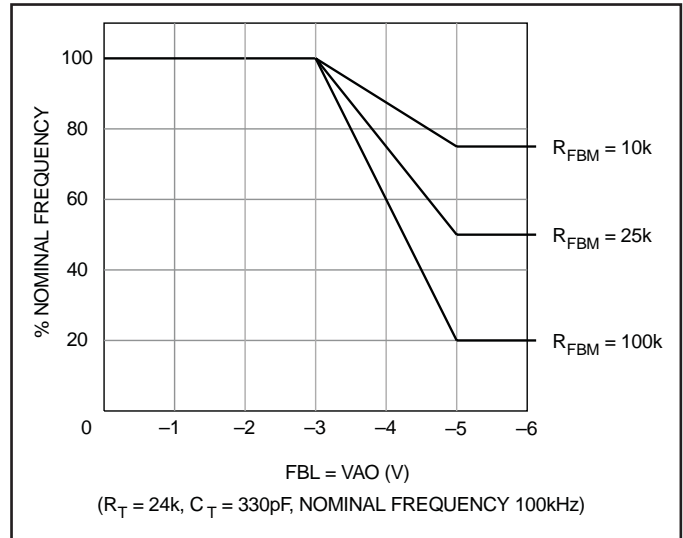

Figure 4. Frequency foldback characteristics.

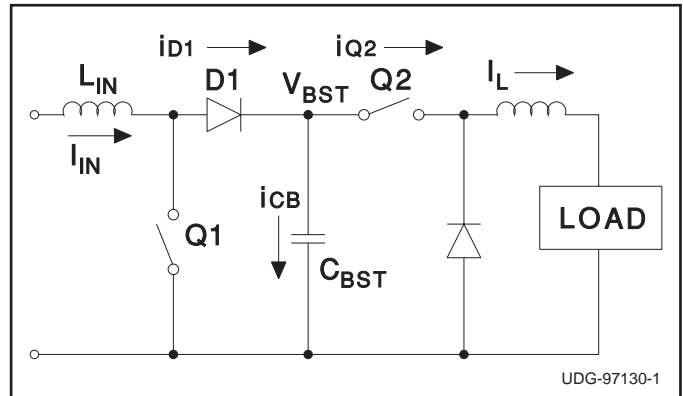

Figure 5. Simplified representation of a 2-stage PFC power supply.

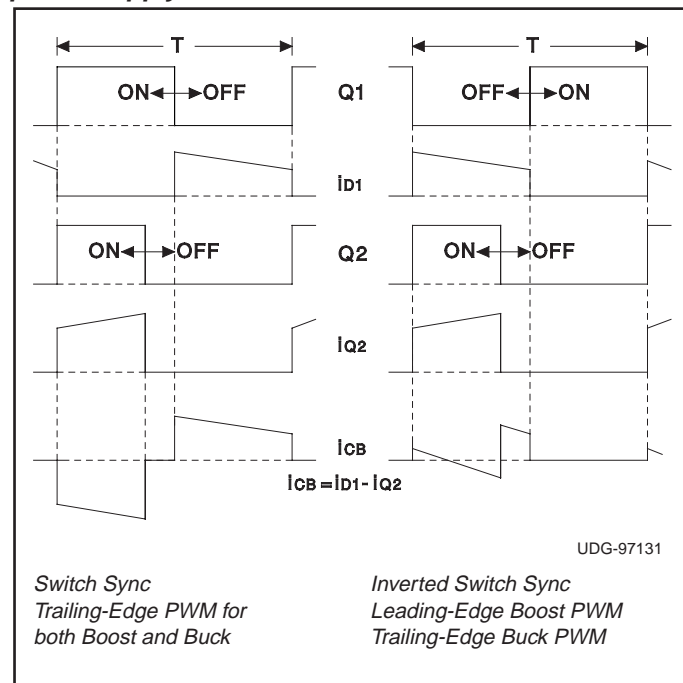

Figure 6. Timing waveforms for synchronization scheme.

APPLICATION INFORMATION (cont.)

Table I. Effects of Synchronization on Boost Capacitor Current

	V _{IN} = 85V		V _{IN} = 120V		V _{IN} = 240V	
D(Q2)	Q1/Q2	D1/Q2	Q1/Q2	D1/Q2	Q1/Q2	D1/Q2
0.35	1.491A	0.835A	1.341A	0.663A	1.024A	0.731A
0.45	1.432A	0.93A	1.276A	0.664A	0.897A	0.614A

Table 1 illustrates that the boost capacitor ripple current can be reduced by about 50% at nominal line and about 30% at high line with the synchronization scheme facilitated by the UCC3858. The output capacitance value can be significantly reduced if its choice is dictated by ripple current or the capacitor life can be increased as a result. In cost sensitive designs where hold-up time is not critical, this is a significant advantage.

An alternative method of synchronization to achieve the same ripple reduction is possible. In this method, the turn-on of Q1 is synchronized to the turn-off of Q2. While this method yields almost identical ripple reduction and maintains trailing edge modulation on both converters, the synchronization is much more difficult to achieve and the circuit can become susceptible to noise as the synchronizing edge itself is being modulated.

Reference Signal (I_{MULT}) Generation

Like the UC3854 series, the UCC3858 has an Analog Computation Unit (ACU) which generates a reference current signal for the current error amplifier. The inputs to the ACU are (signals proportional to) instantaneous line voltage, input voltage RMS information and the voltage error amplifier output. Unlike prior techniques of RMS voltage sensing, UCC3858 employs a patent pending technique to simplify the RMS voltage generation and eliminate performance degradation caused by the prior techniques. With the novel technique (shown in Fig. 7), need for external two pole filter for V_{RMS} generation is eliminated. Instead, the I_{AC} current is mirrored and used to charge an external capacitor (C_{RMS}) during a half cycle. The voltage on C_{RMS} takes the integrated sinusoidal shape and is given by equation 3. At the end of the half-cycle, C_{RMS} voltage is held and converted into a 4-bit digital word for further processing in the ACU. C_{RMS} is discharged and readied for integration during the next half cycle. The advantage of this method is that the second harmonic ripple on the V_{RMS} signal is virtually eliminated. Such second harmonic ripple is unavoidable with the limited roll-off of a conventional 2-pole filter and results in a 3rd harmonic distortion in the input current signal. The dynamic response to the input line variations is also improved as a new V_{RMS} signal is generated every cycle.

$$V_{CRMS} = \frac{I_{AC\ pk}}{2 \cdot \omega \cdot C_{RMS}} \cdot (1 - \cos \omega t) \tag{3a}$$

$$V_{CRMS} (pk) = \frac{I_{AC\ pk}}{\omega \cdot C_{RMS}} \tag{3b}$$

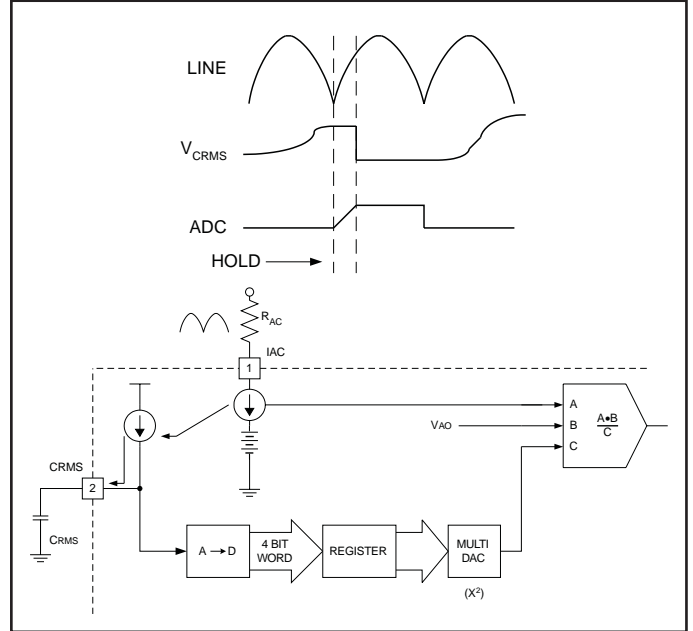

Figure 7. Novel circuit for RMS signal generation.

For proper operation, I_{ACpk} should be selected to be 100µA at peak line voltage. For universal input voltage with peak value of 265 VAC, this means R_{AC} = 3.6M. The noise sensitivity of the IC requires a small bypass capacitor for high frequency noise filtering. The value of this capacitor should be limited to 330pF maximum. The V_{CRMS} value should be approximately 1V at the peak of low line (80 VAC) to minimize any digitization errors. The peak value of V_{CRMS} at high line then becomes 3.5V. The desired C_{RMS} can be calculated from equation 3 to be 90nF for 50Hz line and 75nF for 60Hz line.

The multiplier output current is given by equation (4) with K=0.33.

$$I_{MULT} = \frac{(V_{VAO} - 1) \cdot I_{AC} \cdot K}{V_{CRMS}^2} \tag{4}$$

The multiplier peak current is limited to 200µA and the selected values for I_{AC} and V_{CRMS} should ensure that the current is within this range. Another limitation of the multiplier is that I_{MULT} can not exceed two times the I_{AC} current, limiting the minimum voltage on V_{CRMS}.

APPLICATION INFORMATION (cont.)

The discrete nature of the RMS voltage feedforward means that there are regions of operation where the input voltage changes, but the V_{RMS} value fed into the multiplier does not change. The voltage error amplifier compensates for this by changing its output to maintain the required multiplier output current. When the output of the ADC changes, there is a jump in the output of the error amplifier. There is a resultant shift in the foldback frequency if the converter is at light load. However, the impact of this change is minimal on the overall converter operation.

Another key consideration with the RMS voltage scheme is that it relies on the zero-crossing of the I_{AC} signal to be effective. At very light loads and high line conditions, the rectified AC does not quite reach zero if a large capacitor is being used for filtering on the rectified side of the bridge. In such instances, the feedforward effect does not take place and the controller functionality is lost. For UCC3858, the I_{AC} current should go below $10\mu A$ for the zero crossing detection to take place. It is recommended that the capacitor value be kept low enough for the light load operation or the feedforward be derived directly from the AC side of the input bridge as shown in the typical applications circuit.

Gate Drive Considerations

The gate drive circuit in UCC3858 is designed for high speed power switch drive. It consists of low impedance pull-up and pull-down DMOS output stages. When operating with high bias voltages, in order to stay within the SOA of the DMOS output stages, it is recommended that the gate drive current be limited to 0.5A peak with the use of external gate resistor. Please see the characteristic curve in Fig. 8 for determining the required external resistance.

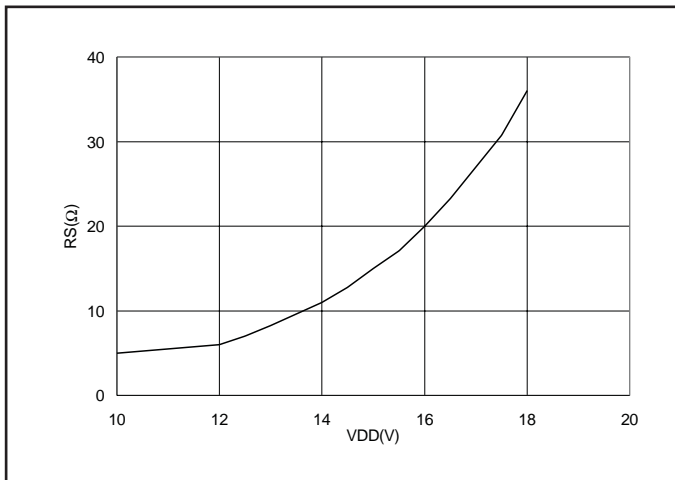

Figure 8. Required series gate resistance as a function of supply voltage.

Current Amplifier Set-up

The multiplier is set-up first by choosing the V_{RMS} range. The maximum multiplier output is at low line, full load conditions. The inductor peak current also occurs at the same point. The multiplier terminating resistor can be determined using equation 5.

$$R_{MULT} = \frac{I_{L-PK} \cdot R_{SENSE}}{I_{MULT-PK}} \quad (5)$$

The peak current limiting function provided by the UCC3858 is integrated into MOUT. The signal on MOUT is normally maintained at 0V as the $(I_{MULT} \cdot R_{MULT})$ cancels the voltage drop across the sense resistor with closed loop operation. During short circuit or transient startup conditions, the multiplier current can not fully cancel the voltage drop across R_{SENSE} and the voltage at MOUT drops below 0V. The internal peak current limit is activated when MOUT drops below $-0.5V$. The peak current limit at any operating point is given by:

$$I_{LIM} = \frac{I_{MULT} \cdot R_{MULT} + 0.5}{R_{SENSE}} \quad (6)$$

The current amplifier can be compensated using previously presented techniques, (Application Note U- 134), summarized here. A simplified high frequency model for inductor current to duty cycle transfer function is given by:

$$G_{id}(s) = \frac{\hat{i}_L}{\hat{d}} = \frac{V_O}{sL} \quad (7)$$

The gain of the current feedback path at the frequency of interest (crossover) is given by:

$$\frac{\hat{d}}{\hat{i}_L} = R_{SENSE} \cdot \frac{R_Z}{R_I} \cdot \frac{1}{V_{SE}} \quad (8)$$

Where V_{SE} is the ramp amplitude (p-p) which is 3.5V for UCC3858. Combining equations 7 and 8 yields the loop gain of the current loop and equating it to 1 at the desired crossover frequency can result in a design value for R_Z . The current loop crossover frequency selected using conventional trade offs. However, it should be ensured that the current-loop is stable at the minimum switching frequency under foldback conditions.

APPLICATION INFORMATION (cont.)

Voltage Amplifier Set-up

The voltage amplifier in UCC3858 is a transconductance type amplifier to allow output voltage monitoring for an overvoltage condition. The gain of the amplifier, given by

APPLICATION INFORMATION (continued)

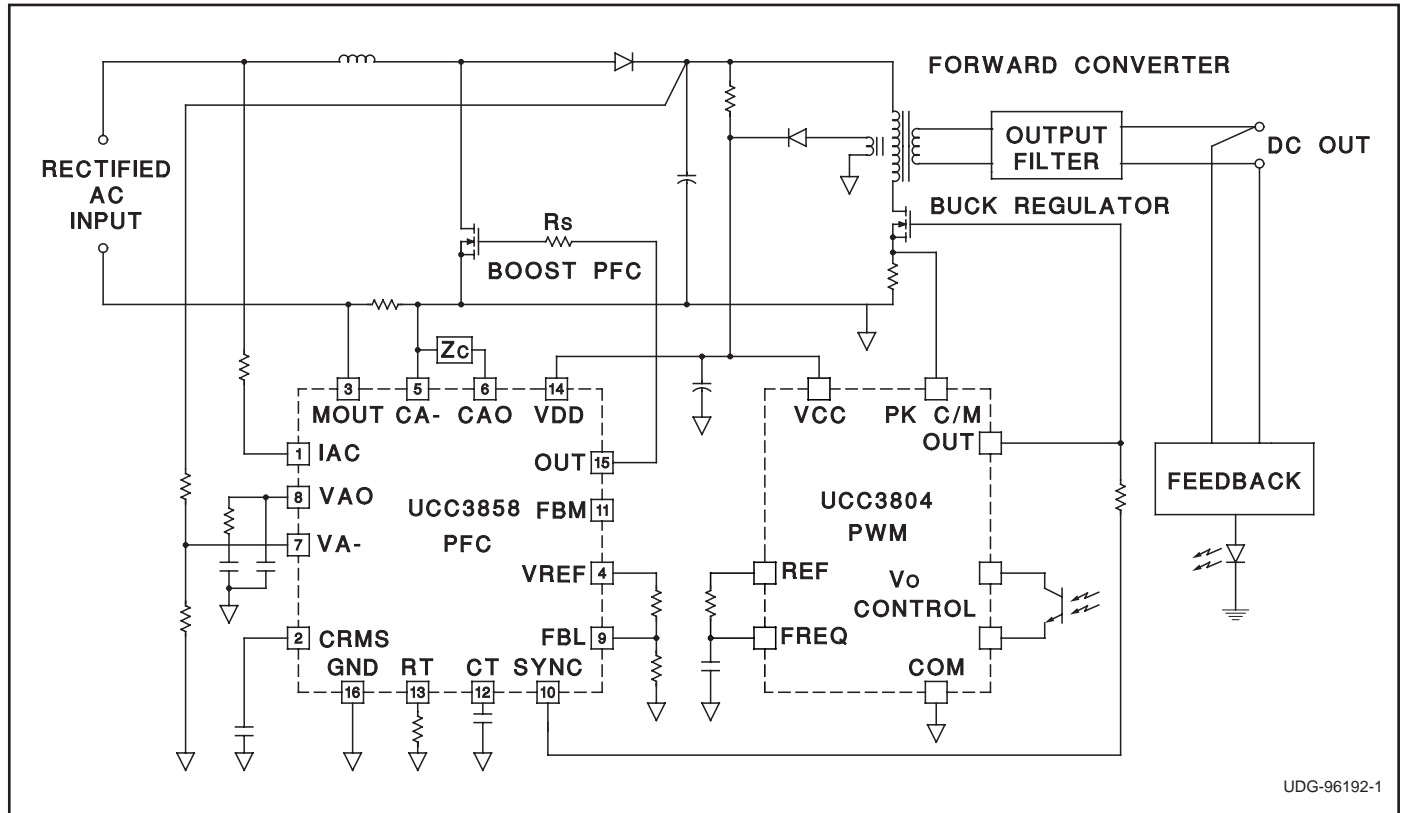

Figure 9. Use of the UCC3858 in a two stage converter to optimize performance.

PACKAGING INFORMATION

Orderable Device	Status ⁽¹⁾	Package Type	Package Drawing	Pins	Package Qty	Eco Plan ⁽²⁾	Lead/Ball Finish	MSL Peak Temp ⁽³⁾
UCC3858DW	OBSOLETE	SOIC	DW	16		TBD	Call TI	Call TI
UCC3858DWTR	OBSOLETE	SOIC	DW	16		TBD	Call TI	Call TI
UCC3858N	OBSOLETE	PDIP	N	16		TBD	Call TI	Call TI

⁽¹⁾ The marketing status values are defined as follows:

ACTIVE: Product device recommended for new designs.

LIFEBUY: TI has announced that the device will be discontinued, and a lifetime-buy period is in effect.

NRND: Not recommended for new designs. Device is in production to support existing customers, but TI does not recommend using this part in a new design.

PREVIEW: Device has been announced but is not in production. Samples may or may not be available.

OBSOLETE: TI has discontinued the production of the device.

⁽²⁾ Eco Plan - The planned eco-friendly classification: Pb-Free (RoHS), Pb-Free (RoHS Exempt), or Green (RoHS & no Sb/Br) - please check <http://www.ti.com/productcontent> for the latest availability information and additional product content details.

TBD: The Pb-Free/Green conversion plan has not been defined.

Pb-Free (RoHS): TI's terms "Lead-Free" or "Pb-Free" mean semiconductor products that are compatible with the current RoHS requirements for all 6 substances, including the requirement that lead not exceed 0.1% by weight in homogeneous materials. Where designed to be soldered at high temperatures, TI Pb-Free products are suitable for use in specified lead-free processes.

Pb-Free (RoHS Exempt): This component has a RoHS exemption for either 1) lead-based flip-chip solder bumps used between the die and package, or 2) lead-based die adhesive used between the die and leadframe. The component is otherwise considered Pb-Free (RoHS compatible) as defined above.

Green (RoHS & no Sb/Br): TI defines "Green" to mean Pb-Free (RoHS compatible), and free of Bromine (Br) and Antimony (Sb) based flame retardants (Br or Sb do not exceed 0.1% by weight in homogeneous material)

⁽³⁾ MSL, Peak Temp. -- The Moisture Sensitivity Level rating according to the JEDEC industry standard classifications, and peak solder temperature.

Important Information and Disclaimer:The information provided on this page represents TI's knowledge and belief as of the date that it is provided. TI bases its knowledge and belief on information provided by third parties, and makes no representation or warranty as to the accuracy of such information. Efforts are underway to better integrate information from third parties. TI has taken and continues to take reasonable steps to provide representative and accurate information but may not have conducted destructive testing or chemical analysis on incoming materials and chemicals. TI and TI suppliers consider certain information to be proprietary, and thus CAS numbers and other limited information may not be available for release.

In no event shall TI's liability arising out of such information exceed the total purchase price of the TI part(s) at issue in this document sold by TI to Customer on an annual basis.

IMPORTANT NOTICE

Texas Instruments Incorporated and its subsidiaries (TI) reserve the right to make corrections, modifications, enhancements, improvements, and other changes to its products and services at any time and to discontinue any product or service without notice. Customers should obtain the latest relevant information before placing orders and should verify that such information is current and complete. All products are sold subject to TI's terms and conditions of sale supplied at the time of order acknowledgment.

TI warrants performance of its hardware products to the specifications applicable at the time of sale in accordance with TI's standard warranty. Testing and other quality control techniques are used to the extent TI deems necessary to support this warranty. Except where mandated by government requirements, testing of all parameters of each product is not necessarily performed.

TI assumes no liability for applications assistance or customer product design. Customers are responsible for their products and applications using TI components. To minimize the risks associated with customer products and applications, customers should provide adequate design and operating safeguards.

TI does not warrant or represent that any license, either express or implied, is granted under any TI patent right, copyright, mask work right, or other TI intellectual property right relating to any combination, machine, or process in which TI products or services are used. Information published by TI regarding third-party products or services does not constitute a license from TI to use such products or services or a warranty or endorsement thereof. Use of such information may require a license from a third party under the patents or other intellectual property of the third party, or a license from TI under the patents or other intellectual property of TI.

Reproduction of TI information in TI data books or data sheets is permissible only if reproduction is without alteration and is accompanied by all associated warranties, conditions, limitations, and notices. Reproduction of this information with alteration is an unfair and deceptive business practice. TI is not responsible or liable for such altered documentation. Information of third parties may be subject to additional restrictions.

Resale of TI products or services with statements different from or beyond the parameters stated by TI for that product or service voids all express and any implied warranties for the associated TI product or service and is an unfair and deceptive business practice. TI is not responsible or liable for any such statements.

TI products are not authorized for use in safety-critical applications (such as life support) where a failure of the TI product would reasonably be expected to cause severe personal injury or death, unless officers of the parties have executed an agreement specifically governing such use. Buyers represent that they have all necessary expertise in the safety and regulatory ramifications of their applications, and acknowledge and agree that they are solely responsible for all legal, regulatory and safety-related requirements concerning their products and any use of TI products in such safety-critical applications, notwithstanding any applications-related information or support that may be provided by TI. Further, Buyers must fully indemnify TI and its representatives against any damages arising out of the use of TI products in such safety-critical applications.

TI products are neither designed nor intended for use in military/aerospace applications or environments unless the TI products are specifically designated by TI as military-grade or "enhanced plastic." Only products designated by TI as military-grade meet military specifications. Buyers acknowledge and agree that any such use of TI products which TI has not designated as military-grade is solely at the Buyer's risk, and that they are solely responsible for compliance with all legal and regulatory requirements in connection with such use.

TI products are neither designed nor intended for use in automotive applications or environments unless the specific TI products are designated by TI as compliant with ISO/TS 16949 requirements. Buyers acknowledge and agree that, if they use any non-designated products in automotive applications, TI will not be responsible for any failure to meet such requirements.

Following are URLs where you can obtain information on other Texas Instruments products and application solutions:

Products

Amplifiers	amplifier.ti.com
Data Converters	dataconverter.ti.com
DSP	dsp.ti.com
Clocks and Timers	www.ti.com/clocks
Interface	interface.ti.com
Logic	logic.ti.com
Power Mgmt	power.ti.com
Microcontrollers	microcontroller.ti.com
RFID	www.ti-rfid.com
RF/IF and ZigBee® Solutions	www.ti.com/lprf

Applications

Audio	www.ti.com/audio
Automotive	www.ti.com/automotive
Broadband	www.ti.com/broadband
Digital Control	www.ti.com/digitalcontrol
Medical	www.ti.com/medical
Military	www.ti.com/military
Optical Networking	www.ti.com/opticalnetwork
Security	www.ti.com/security
Telephony	www.ti.com/telephony
Video & Imaging	www.ti.com/video
Wireless	www.ti.com/wireless

Mailing Address: Texas Instruments, Post Office Box 655303, Dallas, Texas 75265
Copyright © 2008, Texas Instruments Incorporated