



常州市凯丽金电子有限公司---微型贴片电声元器件专业生产商

KELIKING ELECTRONIC-----Micro SMD Buzzer & piezo ceramic manufacturer

SPECIFICATION FOR APPROVAL

承 認 書

Description : SMD Speaker
 Part No : KLJ-01304T-08R07W
 Customer's Model No :
 Specification No : KLJ-01304T-08R07W
 Number Of The Edidion : 3.1

CUSTOMER'S APPROVED SIGNATURE		



凯丽金电子有限公司 KELIKING ELECTRONICS CO., LTD,
 KELLY KING INTERNATIONAL PTE LTD

公司地址: 常州市天宁区恒生科技园 1-1301, Company ADD: Hengsheng1-1301
 Science Park,Tianning District,Changzhou City 工厂地址:常州市天宁区三河口东塘路 1-1
 号,Factory:Dongtang Road NO.1-1 sanhekou Tianning District Changzhou City
 电话: 86-519-88671999-801, Tel: +86-519-88671999-801 传真: +86-519-
 88671999-808, Fax: 86-519-88671999-808 网址: www.kailijin.cn (CN)
www.keliking.com(EN) Http:www.kailijin.cn(CN) www.keliking.com(EN) 邮箱:
jimmy@keliking.com E-mail:jimmy@keliking.com 手机: +86-13656128000 MOB:+86-
 13656128000

Approved by	Checked by	Lssued by



A. SCOPE 範疇

This specification applies SMD Speaker KLJ-01304T-08R07W

B. SPECIFICATION 规格

No.	Item	Unit	Specification
1	Rated Input Power.	W	0.7
2	Max Input Power.	W	1.0
3	Rated Impedance.	Ω	$8 \pm 15\%$
4	Sound Pressure Level. (S.P.L)	dB	$87\text{dB} \pm 3\text{dB}(0.7\text{W}/10\text{cm})$, $70 \pm 3\text{dB}(1\text{W}/1\text{m})$ at AVE 1.0K 1.6K 2.0K 3.2K Hz
5	Resonance Frequency (Fo).	HZ	$850 \pm 20\%$ Hz
6	Frequency Range.	HZ	F0~20kHz.
7	Distortion		Less than 5% at 2KHz input Rated Power
8	Magnet		Rare earth permanent (SMCO) magnet 6.0*1. mm
9	Polarity		When positive voltage is applied to the terminal marked (+), diaphragm should move to the front.
10	Buzz, Rattle, etc.		Should not be audible at 2.53V sine Wave between Fo to 20KHz
11	Appearance		Should not exist any obstacle to be harmful to normal operation; damages, cracks, rusts and distortions, etc.
12	Weight.		1.1g
13	Temperature		Operating temperature: -40°C to $+85^{\circ}\text{C}$ Storage temperature: -40°C to $+85^{\circ}\text{C}$

C. APPEARANCE DRAWING 外觀尺寸图

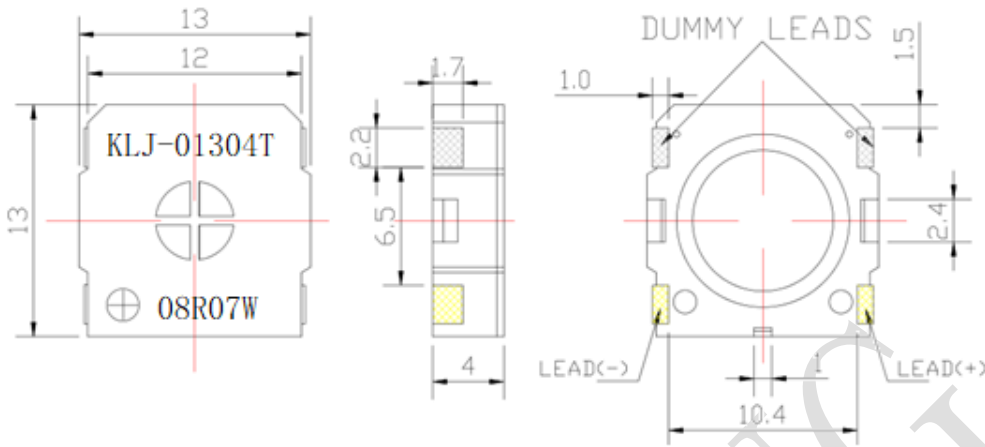

Tolerance general unless otherwise specified: $\pm 0.5\text{mm}$ unit: mm

D. TESTING METHOD

Acoustic Characteristics:

The oscillation frequency, current consumption and sound pressure are measured by the measuring instruments shown below

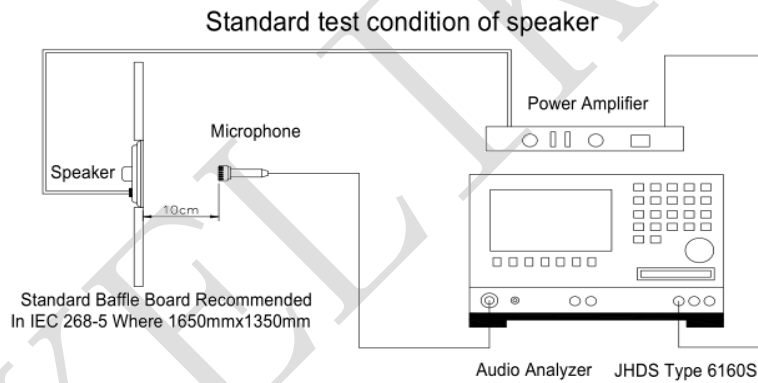

E. Typical Frequency Response Curve



F. RecommendDrivingCircuit

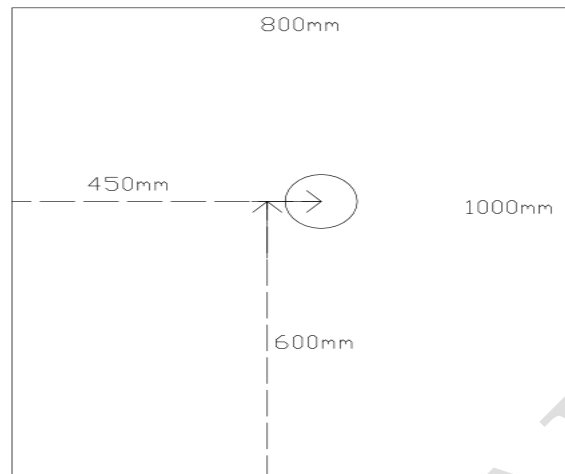
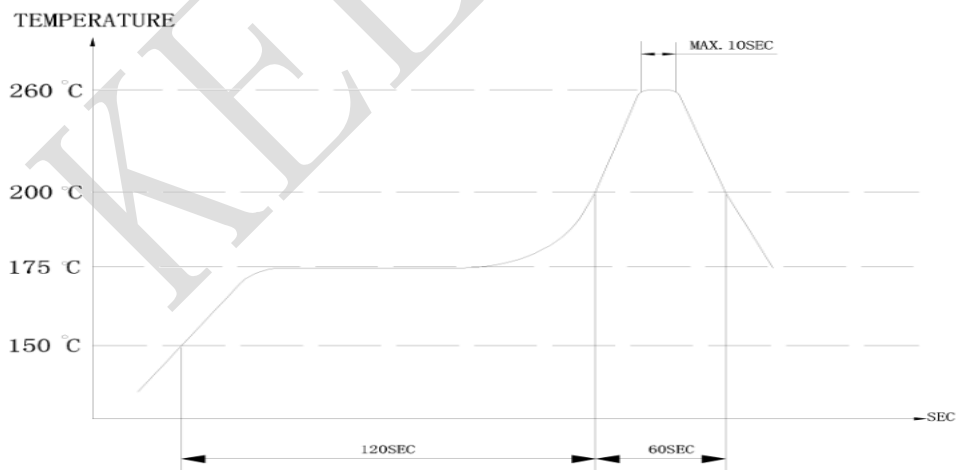

FIG. 1

G. SolderingCondition

(1)Recommendable reflow soldering condition is as follows (Reflow soldering is twice)

Note:Itisrequestedthatreflowsolderingshouldbeexecuted after heat of product goes down to normal.



Heat resistant line(Used when heat resistant reliability test is performed)

(2)Manual soldering Manual soldering temperature 350°C within 5 sec.



H.RELIABILITYTEST

NO.	ITEM	TEST CONDITION AND REQUIREMENT
1	High Temperature Test (Storage)	After being placed in a chamber with $80\pm 2^{\circ}\text{C}$ for 96 hours and then being placed in normal condition for 2 hours. Allowable variation of SPL after test: $\pm 10\text{dB}$.
2	Low Temperature Test (Storage)	After being Placed in a chamber with $-30\pm 2^{\circ}\text{C}$ for 96 hours and then being placed in normal condition for 2 hours. Allowable variation of SPL after test: $\pm 10\text{dB}$.
3	Humidity Test	After being Placed in a chamber with 90-95% R.H. at $40\pm 2^{\circ}\text{C}$ for 96 hours and then being placed in normal condition for 2 hours. Allowable variation of SPL after test: $\pm 10\text{dB}$.

4	Temperature Cycle Test	<p>The part shall be subjected to 5 cycles. One cycle shall be consist of:</p> <p>Allowable variation of SPL after test: $\pm 10\text{dB}$.</p>
5	Drop Test	Drop on a hard wood board of 4cm thick, any directions ,6 times, at the height of 75cm . Allowable variation of SPL after test: $\pm 10\text{dB}$.
6	Vibration Test	After being applied vibration of amplitude of 1.5mm with 10 to 55 Hz band of vibration frequency to each of 3 perpendicular directions for 2 hours . Allowable variation of SPL after test: $\pm 10\text{dB}$.
7	Solderability Test	Lead terminals are immersed in rosin for 5 seconds and then immersed in solder bath of $+300\pm 5^{\circ}\text{C}$ for 3 ± 1 seconds . 90% min. lead terminals shall be wet with solder (Except the edge of terminals).
8	Terminal Strength Pulling Test	The force of 9.8N(1.0kg) is applied to each terminal in axial direction for 10 seconds. No visible damage and cutting off.

TESTCONDITION.

Standard Test Condition : a)Temperature: $+5\sim +35^{\circ}\text{C}$ b)Humidity:45-85%
c)Pressure:860-1060mbar

一般测试条件 : a) 温度 : $+5\sim +35^{\circ}\text{C}$ b) 湿度 :45-85% c) 气压 :860-1060mbar

Judgment Test Condition : a)Temperature: $+25\pm 2^{\circ}\text{C}$ b)Humidity:60-70%

c)Pressure:860-1060mbar

争议时测试条件 : a) 温度 : $+25\pm 2^{\circ}\text{C}$ b) 湿度 :60-70% c) 气压 :860-1060mbar



常州市凯丽金电子有限公司---微型贴片电声元器件专业生产商

KELIKING ELECTRONIC-----Micro SMD Buzzer & piezo ceramic manufacturer

I.PACKINGSTANDARD

