

### FEATURES

- $R_{DS(ON)} < 1.75\Omega @ V_{GS} = 10V$
- Fast Switching Capability
- Avalanche Energy Specified
- Improved dv/dt Capability, High Ruggedness

### APPLICATIONS

- High frequency switching mode power supply
- Electronic ballast
- LED power supply

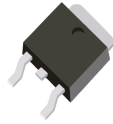

### PRODUCT CHARACTERISTICS

TO-252

VDSS	500V
$R_{DS(on)max}(@V_{GS} = 10 V)$	1.75 $\Omega$
Qg@type	24nC
ID	5A

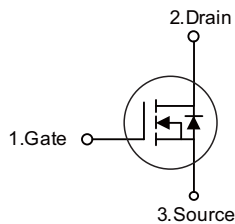

### TO-252

Unit: mm

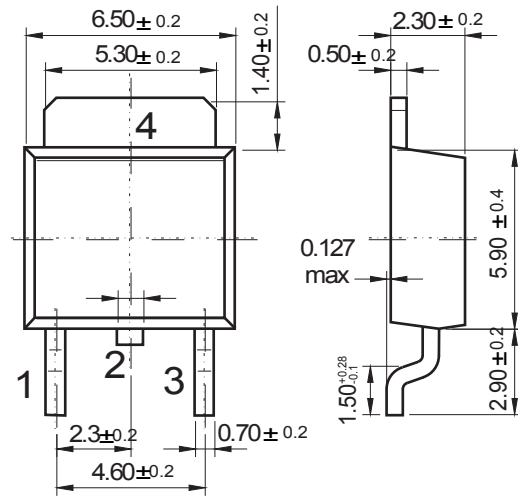

Dimensions in inches and (millimeters)

### ABSOLUTE MAXIMUM RATINGS (T<sub>c</sub> = 25°C, unless otherwise specified)

PARAMETER	SYMBOL	RATINGS	UNIT
Drain-Source Voltage	V <sub>DSS</sub>	500	V
Gate-Source Voltage	V <sub>GSS</sub>	±30	V
Drain Current	Continuous	I <sub>D</sub>	5
	Pulsed (Note 2)	I <sub>DM</sub>	20
Avalanche Current (Note 2)	I <sub>AR</sub>	5	A
Avalanche Energy	Single Pulsed (Note 3)	E <sub>AS</sub>	300
	Repetitive (Note 2)	E <sub>AR</sub>	7.3
Peak Diode Recovery dv/dt (Note 4)	dv/dt	4.5	V/ns
Power Dissipation	P <sub>D</sub>	125	W
Junction Temperature	T <sub>J</sub>	+150	°C
Storage Temperature	T <sub>STG</sub>	-55~+150	°C

Note: 1. Absolute maximum ratings are those values beyond which the device could be permanently damaged.

Absolute maximum ratings are stress ratings only and functional device operation is not implied.

2. Repetitive Rating: Pulse width limited by maximum junction temperature

3. L = 21.5mH, I<sub>AS</sub> = 5A, V<sub>DD</sub> = 50V, R<sub>G</sub> = 25 $\Omega$ , Starting T<sub>J</sub> = 25°C

4. I<sub>SD</sub> ≤ 5A, di/dt ≤ 200A/ $\mu$ s, V<sub>DD</sub> ≤ BV<sub>DSS</sub>, Starting T<sub>J</sub> = 25°C

# 5N50

ELECTRICAL CHARACTERISTICS ( $T_C = 25^\circ\text{C}$ , unless otherwise specified)

PARAMETER	SYMBOL	TEST CONDITIONS	MIN	TYP	MAX	UNIT
<b>OFF CHARACTERISTICS</b>						
Drain-Source Breakdown Voltage	$BV_{DSS}$	$I_D=250\mu\text{A}$ , $V_{GS}=0\text{V}$	500			V
Breakdown Voltage Temperature Coefficient	$\Delta BV_{DSS}/\Delta T_J$	Reference to $25^\circ\text{C}$ , $I_D=250\mu\text{A}$		0.5		$\text{V}/^\circ\text{C}$
Drain-Source Leakage Current	$I_{DSS}$	$V_{DS}=500\text{V}$ , $V_{GS}=0\text{V}$			1	$\mu\text{A}$
		$V_{DS}=400\text{V}$ , $T_C=125^\circ\text{C}$			10	
Gate- Source Leakage Current	Forward	$I_{GSS}$			100	nA
	Reverse					
					-100	nA
<b>ON CHARACTERISTICS</b>						
Gate Threshold Voltage	$V_{GS(TH)}$	$V_{DS}=V_{GS}$ , $I_D=250\mu\text{A}$	2.0		4.0	V
Static Drain-Source On-State Resistance	$R_{DS(ON)}$	$V_{GS}=10\text{V}$ , $I_D=2.5\text{A}$		1.45	1.75	$\Omega$
<b>DYNAMIC PARAMETERS</b>						
Input Capacitance	$C_{ISS}$	$V_{GS}=0\text{V}$ , $V_{DS}=25\text{V}$ , $f=1.0\text{MHz}$		480	625	pF
Output Capacitance	$C_{OSS}$			80	105	pF
Reverse Transfer Capacitance	$C_{RSS}$			15	20	pF
<b>SWITCHING PARAMETERS</b>						
Total Gate Charge	$Q_G$	$V_{GS}=10\text{V}$ , $V_{DS}=400\text{V}$ , $I_D=5\text{A}$ (Note 1, 2)		18	24	nC
Gate to Source Charge	$Q_{GS}$			2.2		nC
Gate to Drain Charge	$Q_{GD}$			9.7		nC
Turn-ON Delay Time	$t_{D(ON)}$	$V_{DD}=250\text{V}$ , $I_D=5\text{A}$ , $R_G=25\Omega$ (Note 1, 2)		12	35	ns
Rise Time	$t_R$			46	100	ns
Turn-OFF Delay Time	$t_{D(OFF)}$			50	110	ns
Fall-Time	$t_F$			48	105	ns
<b>SOURCE- DRAIN DIODE RATINGS AND CHARACTERISTICS</b>						
Maximum Continuous Drain-Source Diode Forward Current	$I_S$				5	A
Maximum Pulsed Drain-Source Diode Forward Current	$I_{SM}$				20	A
Drain-Source Diode Forward Voltage	$V_{SD}$	$I_S=5\text{A}$ , $V_{GS}=0\text{V}$			1.4	V
Reverse Recovery Time	$t_{rr}$	$I_S=5\text{A}$ , $V_{GS}=0\text{V}$ , $di_F/dt=100\text{A}/\mu\text{s}$ (Note 1)		83		ns
Reverse Recovery Charge	$Q_{RR}$			0.25		$\mu\text{C}$

Note: 1. Pulse Test: Pulse width  $\leq 300\mu\text{s}$ , Duty cycle  $\leq 2\%$   
 2. Essentially independent of operating temperature

## RATING AND CHARACTERISTIC CURVES (5N50)

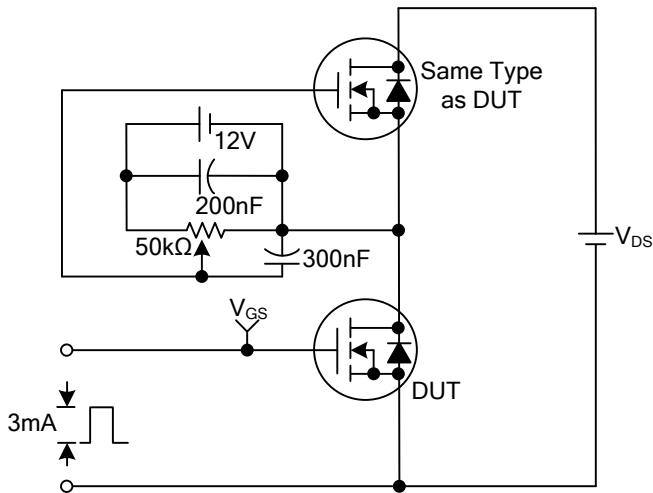

**Gate Charge Test Circuit**

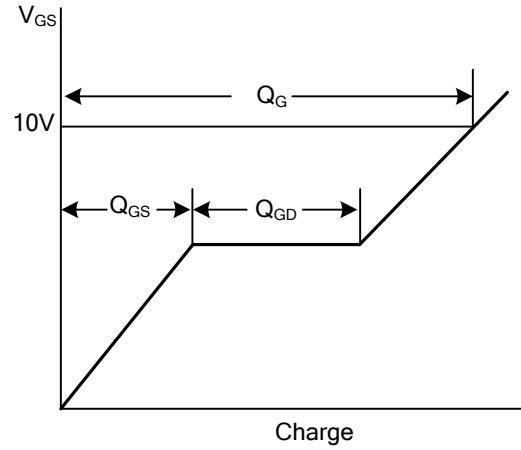

**Gate Charge Waveforms**

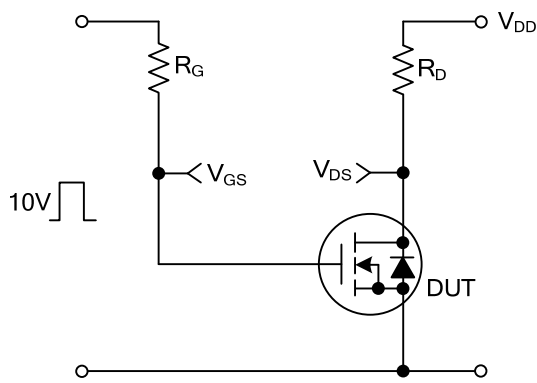

**Resistive Switching Test Circuit**

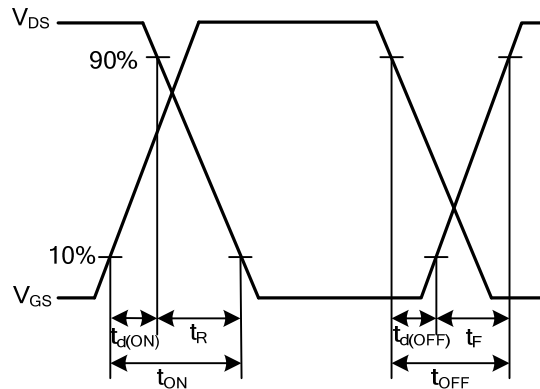

**Resistive Switching Waveforms**

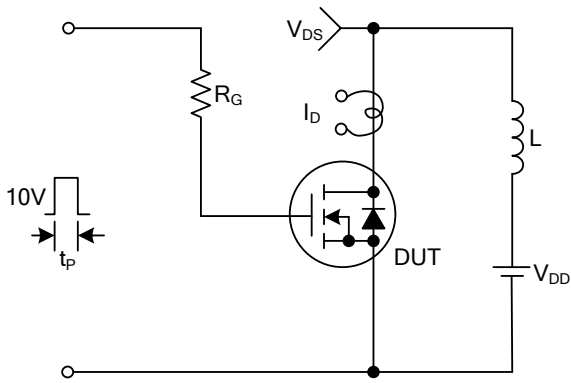

**Unclamped Inductive Switching Test Circuit**

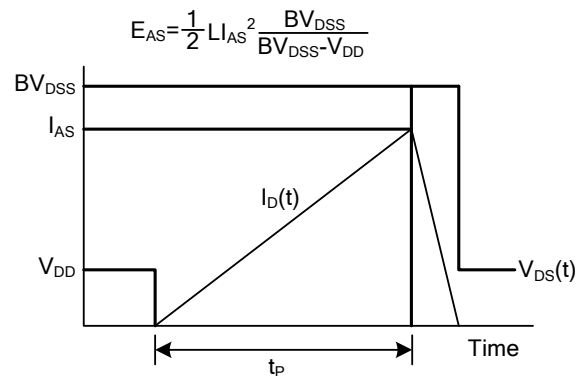

**Unclamped Inductive Switching Waveforms**