

REV.	ECN NO.	DESCRIPTION	DRWN	APPD.	DATE
REV.	ECN NO.	DESCRIPTION	DR.	APPD.	DATE

**SPEC:**

**Current Rating: 3Amps**  
**Insulator Resistance: 5000Ω Min**  
**Dielectric Withstanding: AC 500V**  
**Operating Temperature: -40° to+105°**  
**Contact Material: Copper alloy T=0.25**  
**Insulator Material: Polyester, UL 94V-0 LCP**  
**Finish :**  
 Gold/tin plating on contact area  
 100u" min. Tin-Lead Plating on soldertails  
 50u" min. nickel under plating over all tin,  
 Max. Processing Temp:  
 230C° for 30-60seconds (260C° for 10 secinds)

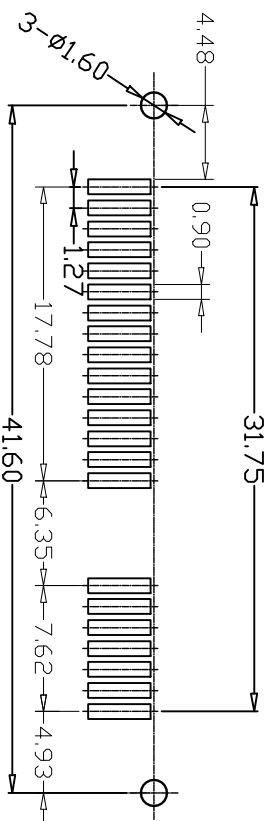
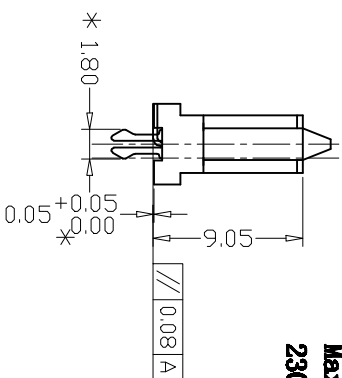
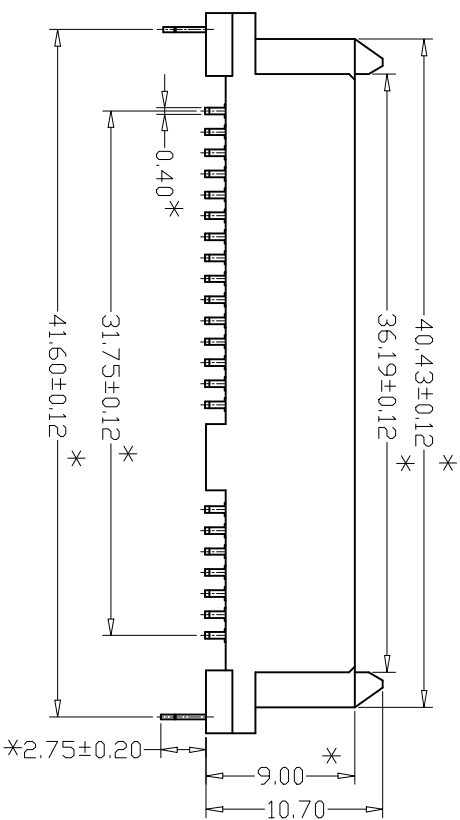
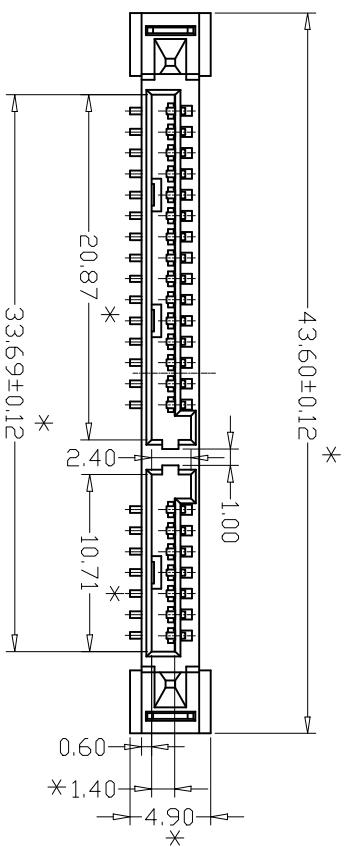

**深圳市连欣科技有限公司**

**TITLE:**

**SATA 7+15P 立式SMT H10.7MM**

**PART NO. XUTS-2219-1070**

UNITS	SCALE	REV.	SHEET
mm	SCALE	REV.	PAGE
0.		DATE	D_DATE
0.0		DR.	DESIGNER
0.00		CHK.	
0°		APPD.	
0.0°		DWG.NO.	DWG.NO.
		C	
		SIZE	A4