

1 2 3 4 5 6 7

REV.	DESCRIPTION	DATE
A/0		

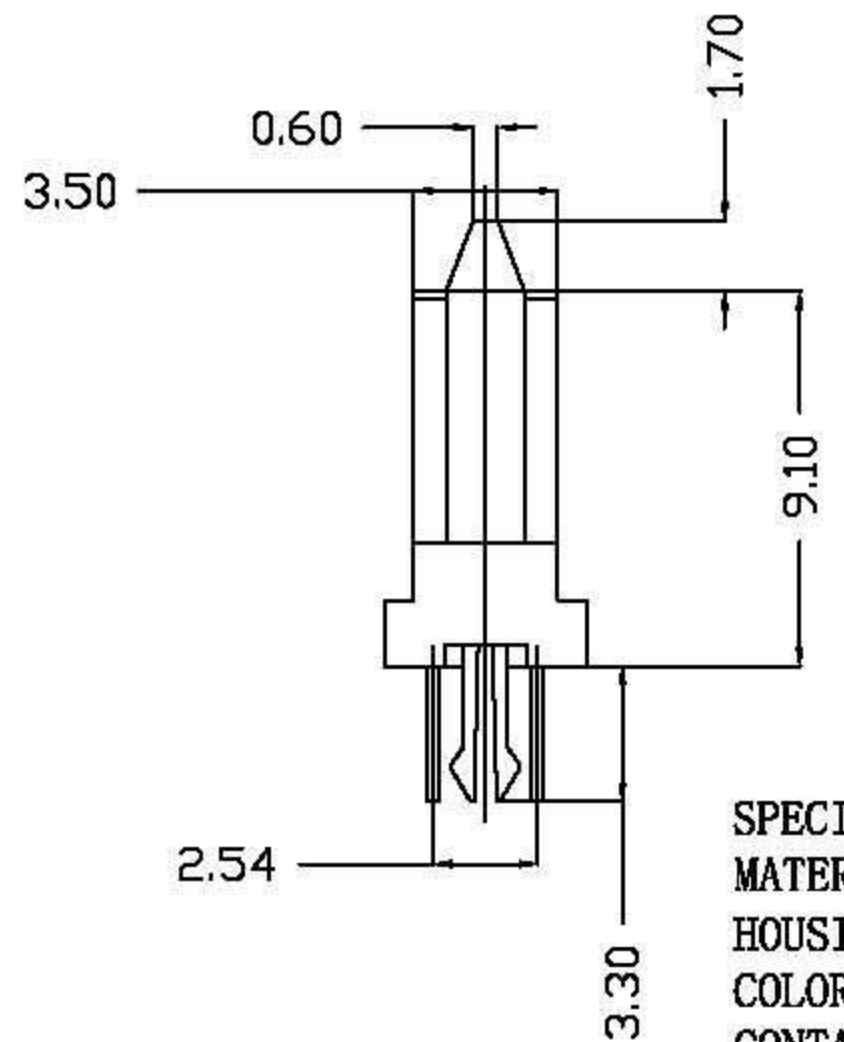

SPECIFICATION:
MATERIAL:
 HOUSING: LCP LG431-9731L 30% G/F UL 94V-0
 COLOR: BLACK
 CONTACT: BRASS C2680R EH, T=0.25mm
 PEG: BRASS C2680R H, T=0.30mm
FINISH:
 CONTACT: 10u" GOLD/TIN PLATING ON CONTACT AREA
 100u" MIN. TIN-LEAD PLATING ON SOLDER TAILS
 50u" MIN. NICKEL UNDERPLATING OVERALL
 PEG: 100u" MIN. TIN-LEAD PLATING ON SOLDER TAILS
 50u" MIN. NICKEL UNDERPLATING OVERALL

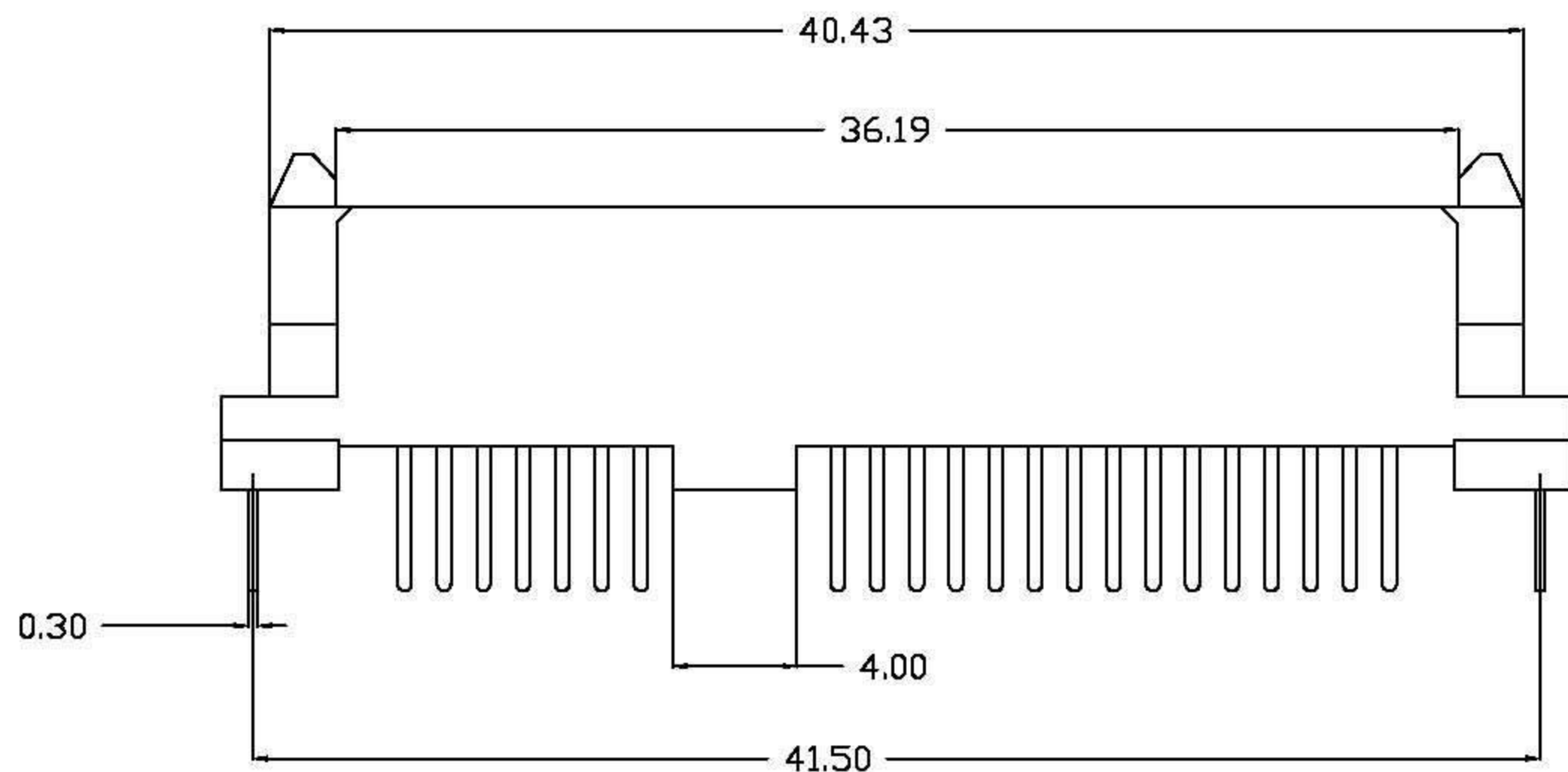
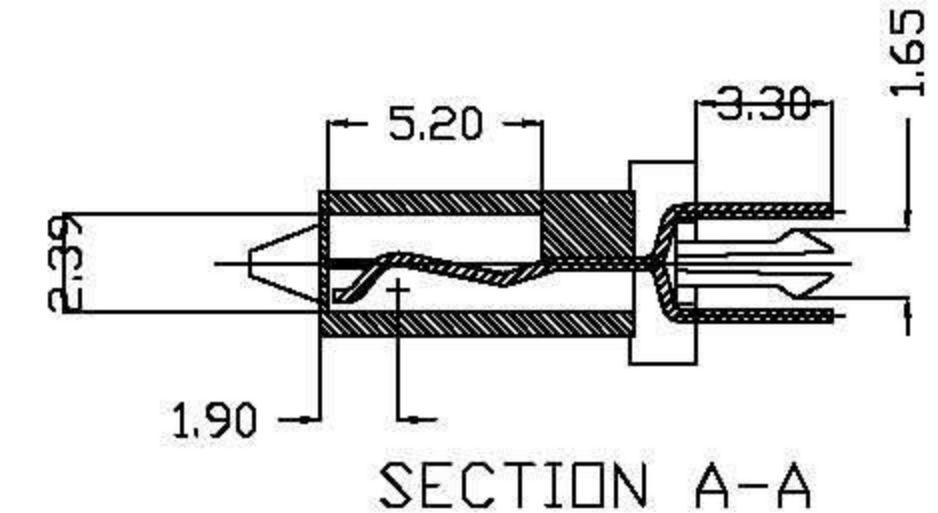
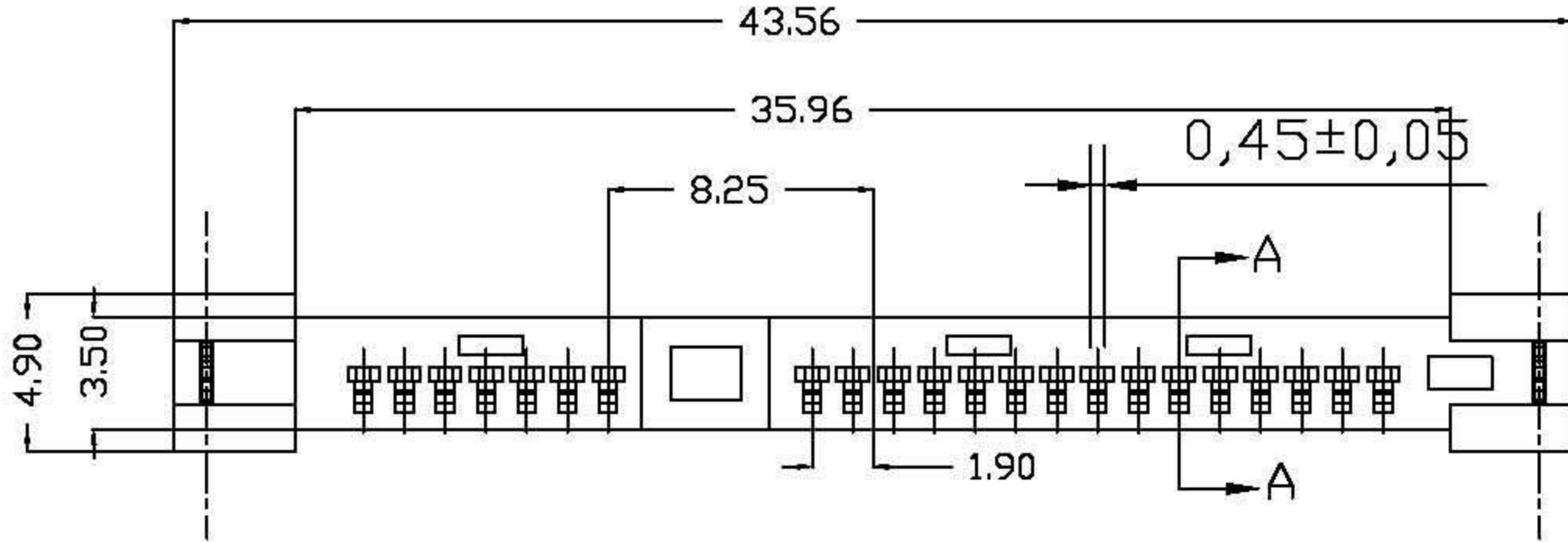
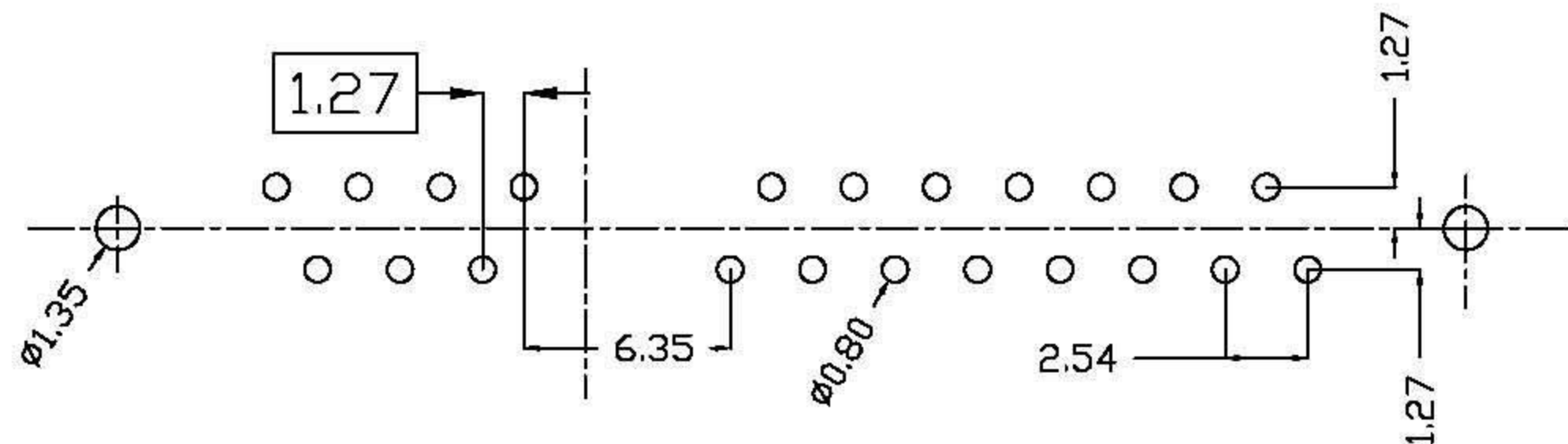

L&X 深圳市连欣科技有限公司

X. ±0.15 X.X ±0.10 X.XX ±0.05 X.XXX ±0.010 X.* ±5° X.X* ±1°	DRAWN BY:	DATE:	PART NAME: SATA7+15P 双排180度	
	CHECKED BY:	DATE:	PART NO.	XUTS-2218-03
 UNIT: mm [inch]	APPROVAL BY:	DATE:	MOLD NO.	
SCALE: 1:1	SIZE: A4		PRODUCT SPEC.	
			DRAW NO.	DWG2218003A1

1 2 3 4 5 6 7