

REV.	DESCRIPTION	APPD	DATE

NOTES:
 1.MATERIAL:
 HOUSING: HIGH TEMPERATURE THERMOPLASTIC
 UL94V_0,COLOR:BLACK.
 CONTACT: COPPER ALLOYS.
 COVER: COPPER ALLOYS
 2.PLATING:
 UNDERPLATE: NICKEL.
 CONTACT AREA: GOLD OVER NICKEL.
 SOLDER AREA: TIN OVER NICKEL.
 3.MULTIMEDIA CARD COMPATIBLE

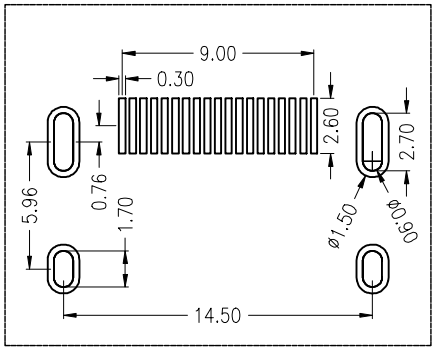
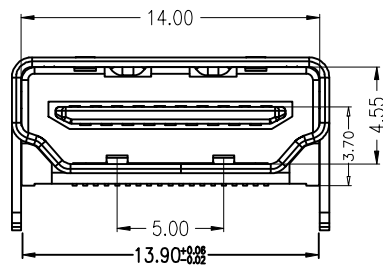
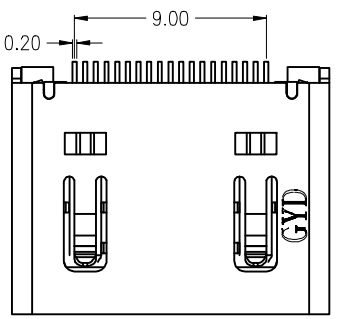
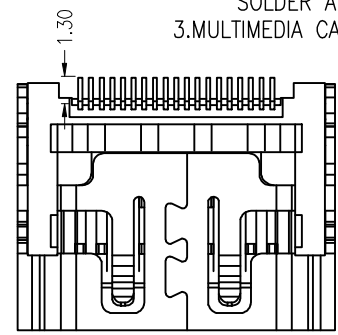
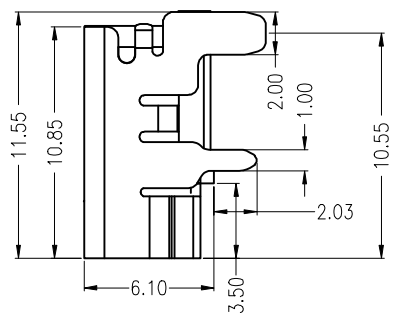
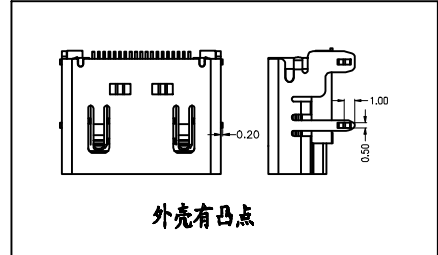

RECOMMENDED P.C.B HOLE LAYOUT
 COMPONENT SIDE VIEW(TOLERANCE: +/-0.05)

DWG NO: HDMI-10071		MATERIAL:		深圳市连欣科技有限公司	
LOT NO:		FINSH:			
UNIT: MM	SIZE: A4	COLOR:		TITLE:	
TOLERANCES: X,X=±0.35 X,XX=±0.25 X,XXX=±0.15		GENERAL ANGLE: X,X=±3.0° X,XX=±2.0°		DR: 0609'10	
CHK:		APP:		PART NO: XDHF-1901-C820	REV: C/0
SCALE: 1:1		SHEET: 1 OF 4			