

NOTES:

- 1.HUOSINGT:LCP HIGH-TEMP THERMOPLASTIC UL94V-0
COLOR:BEIGE
- 2.ACTUATOR:LCP HIGH-TEMP THERMOPLASTIC UL94V-0
COLOR:BLACK
- 3.TERMINAL:COPPER ALLOOY
PLATING:GOLD FLASH OR MATTE-TIN OR TIN (LEAD FREE)
- 4.FITTING NAIL:COPPER ALLOOY
PLATING:MATTE-TIN OR TIN (LEAD FREE)

No. of Contacts	Dimension				
	A	B	C	D	E
13	6.10	3.00	3.60	4.23	5.57
15	6.70	3.60	4.20	4.83	6.17
17	7.30	4.20	4.80	5.43	6.77
19	7.90	4.80	5.40	6.03	7.37
21	8.50	5.40	6.00	6.63	7.97
23	9.10	6.00	6.60	7.23	8.57
25	9.70	6.60	7.20	7.83	9.17
27	10.30	7.20	7.80	8.43	9.77
29	10.90	7.80	8.40	9.03	10.37
31	11.50	8.40	9.00	9.63	10.97
33	12.10	9.00	9.60	10.23	11.57
35	12.70	9.60	10.20	10.83	12.17
37	13.30	10.20	10.80	11.43	12.77
39	13.90	10.80	11.40	12.03	13.37
41	14.50	11.40	12.00	12.63	13.97
45	15.70	12.60	13.20	13.83	15.17
49	16.90	13.80	14.40	15.03	16.37
51	17.50	14.40	15.00	15.63	16.97
57	19.30	16.20	16.80	17.43	18.77
61	20.50	17.40	18.00	18.63	19.97
67	22.30	19.20	19.80	20.43	21.77
71	23.50	20.40	21.00	21.63	22.97
73	24.10	21.00	21.60	22.23	23.57

CUSTOMER 深圳市连欣科技有限公司
 TEL: 0755-33978030 FAX: 0755-32937438

REV: B	SIZE: A4	GENERAL TOLERANCE UNLESS OTHERWISE SPECIFIED X.X ±0.20 X.XX ±0.15 X.XXX	PART NO: XDFC-0312-**-P
UNIT: mm	SCALE: 5:1		
SHEET NO: 1 OF 1		TITLE: 0.3mm BACK-FLIP SMT BOTTOM CONNECTOR	
DRAWN BY: Kavin 2013-02-28		CHECKED BY:	APPROVED BY:

SER	REVISIONS	CHK	DATE

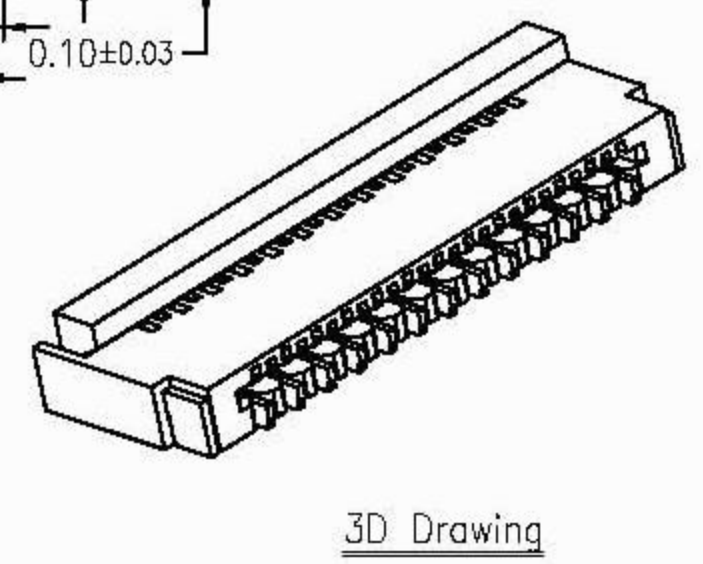

FPC/FFC Insert Direction
 Recommended P.C.B Layout

Applicable FPC