

REV.	ECRN NO./DESCRIPTION	DATE	DRAWN	CHECKED	APPROVE
10	SN12124	07/02/12	Tracy	Raymond	Barney
10A	SR12***	08/13/12	Tracy	Raymond	Barney
10B	SR12***	01/09/13	Tracy	Raymond	Barney

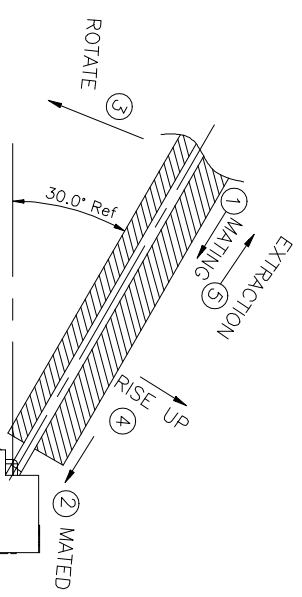

TABLE

9	AAA-PCI-047-P14_A	BLACK,Au 150u" HF
8	AAA-PCI-047-P13	BLACK,Au 50u" HF
7	AAA-PCI-047-P11_A	WHITE,Au 100u" HF
6	AAA-PCI-047-P10P10_A	BLACK,Au 100u" HF
5	AAA-PCI-047-P06	WHITE,Au10u" HF
4	AAA-PCI-047-P05	BLACK,Au 30u" HF
3	AAA-PCI-047-P01/P02	BLACK,Au1u" MIN HF
2	AAA-PCI-047-K04	BLACK,Au 30u"
1	AAA-PCI-047-K01/K02	BLACK,Au1u" MIN

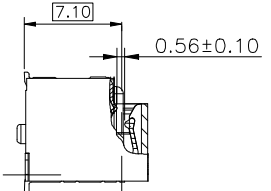
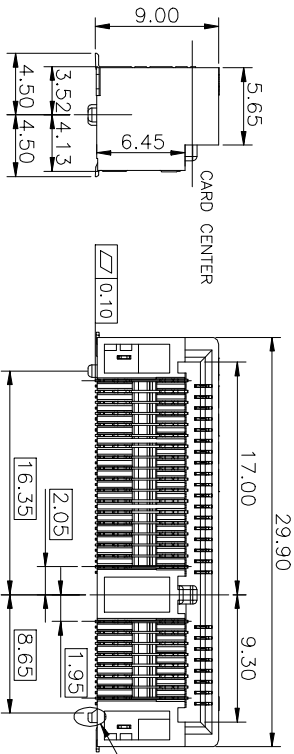
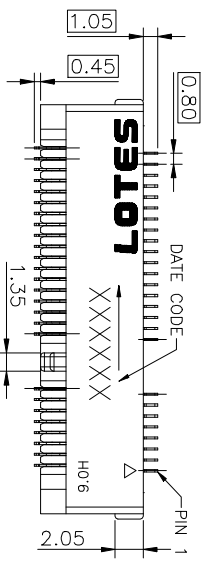
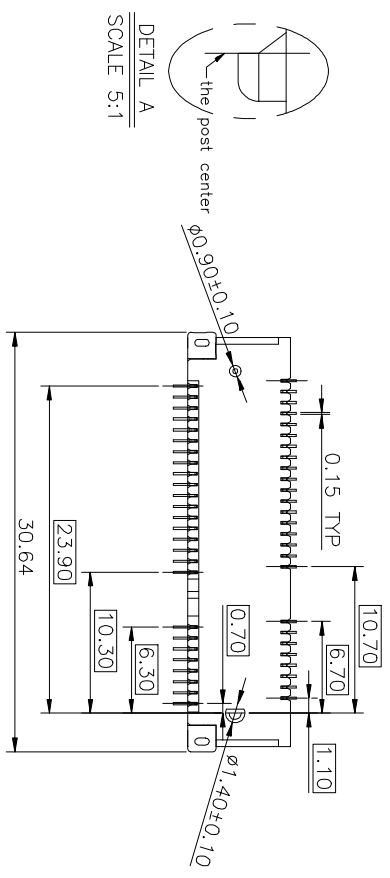

NO.	PART NO.	DESCRIPTION
GENERAL TOLERANCES UNLESS SPECIFIED		
X ± 0.35	X ± 3°	SEE TABLE
XX ± 0.25	X ± 2°	APPROVED BY Barney
XXX ± 0.15	XX ± 1°	CHECKED BY Raymond
CUSTOMER DRAWING		
SIZE	UNITS	DRAWN BY XU
A4	MM [INCH]	
DWG NO. AP-AAA-PCI-047		
TITLE MINI PCI EXPRESS 9.0H 0.8PITCH 52P		
SHEET 1 / 6		
SCALE 2 : 1		
REV 10B		



NOTES:
 1. MATERIAL:
 CONTACT:C2680,50u"Min.NICKEL UNDERPLATING.
 GOLD FLASH ON SOLDER AREA.
 GOLD PLATING ON CONTACT AREA (DETAIL SEE TABLE)
 PEG:C2680,50u"Min.NICKEL UNDERPLATING,
 MATTE-Tin, 100u"Min OVER NICKEL.
 HOUSING:LCP+30%GF,UL-94V0

2. ROHS,HF COMPLIANT.
 3. ELECTRICAL PERFORMANCE
 CONTACT RESISTANCE:55mΩ MAX.PER CONTACT
 INSULATION RESISTANCE:500MΩ MIN
 4. MECHANICAL PERFORMANCE
 DURABILITY:50 CYCLES
 MATING AND UNMATING FORCE:2.3Kgf MAX
 5. IR REFLOW TEMPERATURE:250°C±10°C FOR 10 SECONDS MAX.
 6. PRODUCT NUMBER NOTE:AAA-PCI-***-*** *

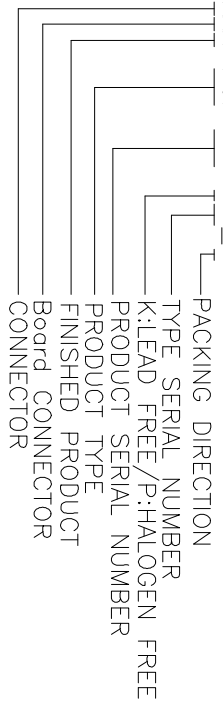

7. DATE CODE NOTE:
 XXXXXX

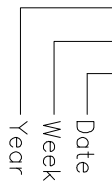

GENERAL TOLERANCES UNLESS SPECIFIED		PART NO.	TITLE		
X[±] 0.35	X [±] 3°	SEE TABLE	MINI PCI EXPRESS 9.0H		
XX ± 0.25	X [±] 2°	APPROVED BY	0.8PITCH 52P		
XXX ± 0.15	XX [±] 1°	Battney	DWG NO.		
CUSTOMER DRAWING		CHECKED BY	AP-AAA-PCI-047		
SIZE	UNITS	DRAWN BY	SHEET	SCALE	REV
A4	MM	XU	2 / 6	5 : 2	10B



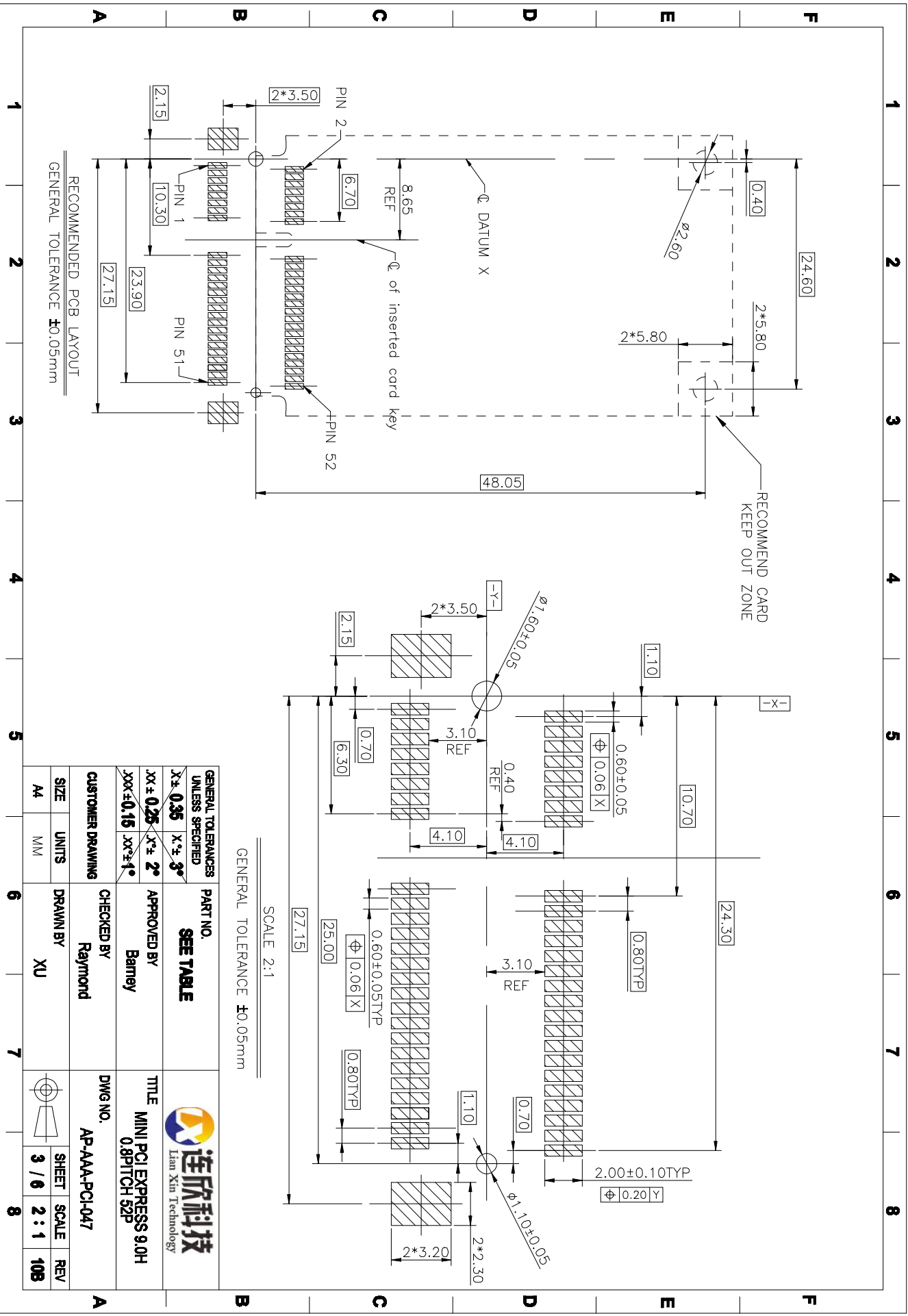

RECOMMENDED PCB LAYOUT
GENERAL TOLERANCE $\pm 0.05\text{mm}$

RECOMMEND CARD
KEEP OUT ZONE

SCALE 2:1
GENERAL TOLERANCE $\pm 0.05\text{mm}$

GENERAL TOLERANCES UNLESS SPECIFIED		PART NO.	TITLE	
$X \pm 0.35$	$X \pm 3^\circ$	SEE TABLE	MINI PCI EXPRESS 9.0H	
$XX \pm 0.25$	$X \pm 2^\circ$	APPROVED BY	0.8PITCH 52P	
$XXX \pm 0.15$	$XX \pm 1^\circ$	Baimy	Lian Xin Technology	
CUSTOMER DRAWING		CHECKED BY	DWG NO.	
Raymond		Raymond	AP-AAA-PCI-047	
SIZE	UNITS	DRAWN BY	SHEET	
A4	MM	XU	3 / 6	
			SCALE	REV
			2 : 1	108



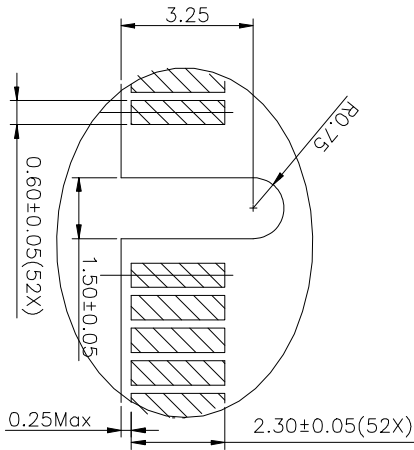
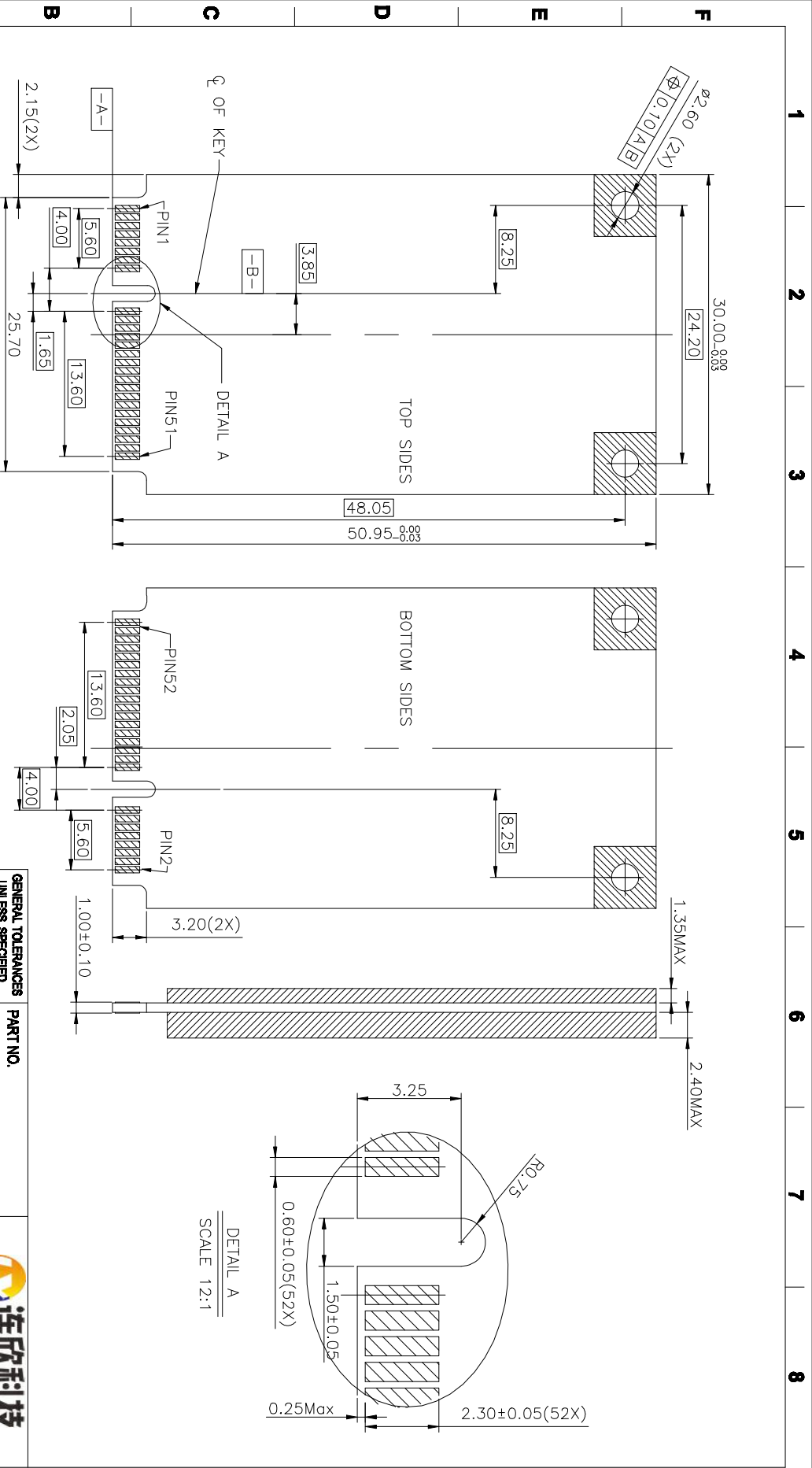

DETAIL A
SCALE 12:1

MINI PCI EXPRESS MODULE BOARD LAYOUT

GENERAL TOLERANCES UNLESS SPECIFIED		PART NO. SEE TABLE		TITLE MINI PCI EXPRESS 9.0H 0.9PITCH 52P	
$X \pm 0.35$	$X \pm 0.3^\circ$	APPROVED BY Barney	DWG NO. AP-AAA-PCI-047	SHEET SCALE REV	
$XX \pm 0.25$	$X \pm 2^\circ$	CHECKED BY Raymond	AP-AAA-PCI-047	4 / 6	2 / 1
$XXX \pm 0.15$	$XX \pm 1^\circ$	DRAWN BY XU		108	



CUSTOMER DRAWING	SIZE A4	UNITS MM	DWG NO. AP-AAA-PCI-047	SHEET 4 / 6	SCALE 2 / 1	REV 108
------------------	---------	----------	------------------------	-------------	-------------	---------

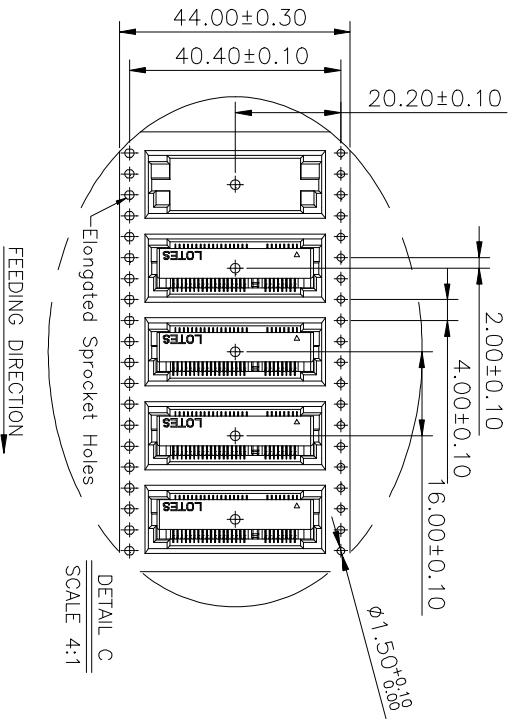
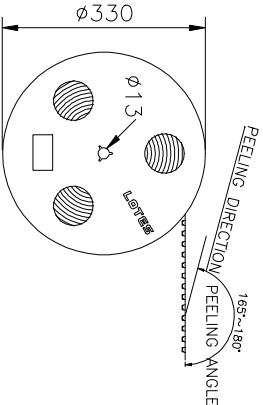
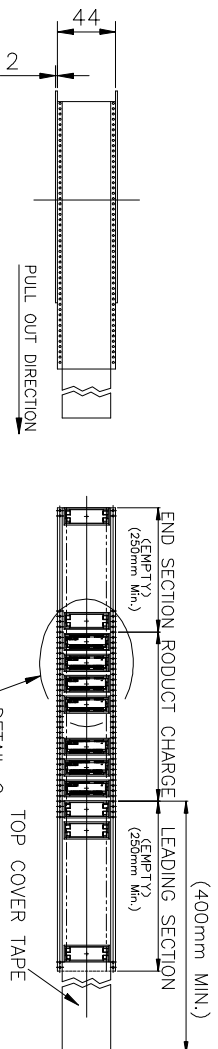

AAA-PCI-047-K01/K04/P01/P05/P06/P10/P13/P14

- NOTES:
- MATERIAL :
 - CARRY TAPE: PS
 - COVER TAPE: PET
 - SHIPPING CARTON: CORRUGATED FIBER
 - DIMENSION :
 - REEL: W=44.5, $\phi A=330$
 - SHIPPING CARTON: L=335, W=335, H=300 (INNER)
 - QUANTITY :
 - PRIMARY PACKING: 350 PCS/REEL
 - SECONDARY PACKING: 6 REELS/CARTON(2100PCS)
 - PEELING RESISTANCE: 20gf~120gf.
 - PEELING SPEED: 300mm/minutes.

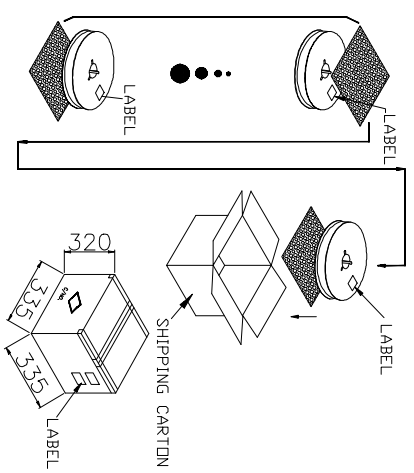

GENERAL TOLERANCES UNLESS SPECIFIED		PART NO. SEE TABLE		TITLE	
X ± 0.35	X ± 3°	APPROVED BY Barney		MINI PCI EXPRESS 9.0H	
XX ± 0.25	X ± 2°	CHECKED BY Raymond		0.8PITCH 52P	
XXX ± 0.16	XX ± 1°	DRAWN BY XU		DWG NO. AP-AAA-PCI-047	
CUSTOMER DRAWING		DRAWN BY XU		SHEET 5 / 6	
SIZE A4	UNITS MM			SCALE N/A	
				REV 109	



Lian Xin Technology

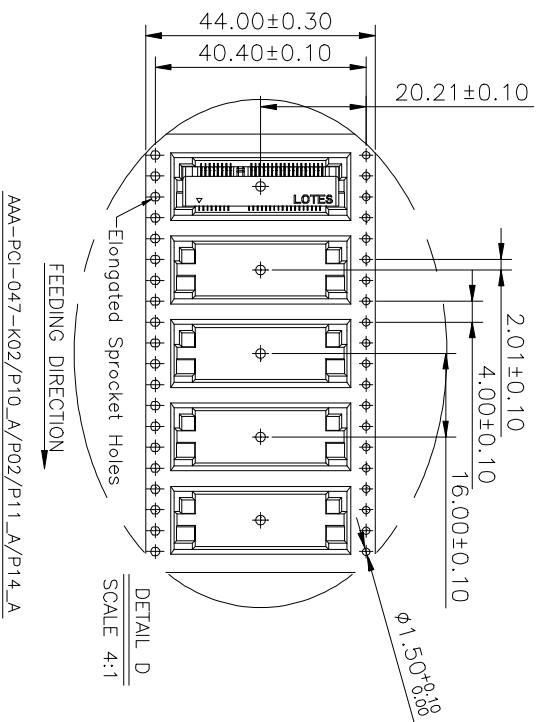
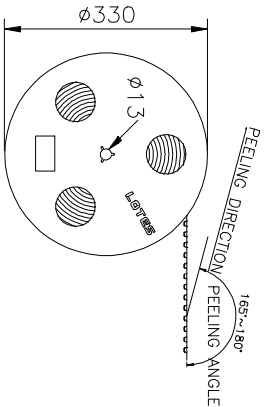
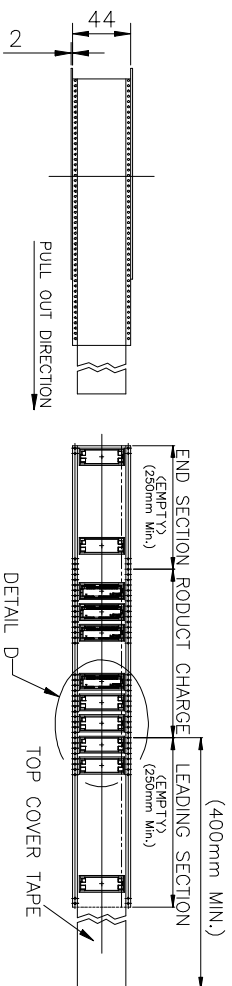

- NOTES:
- MATERIAL :
 - CARRY TAPE: PS
 - COVER TAPE: PET
 - SHIPPING CARTON: CORRUGATED FIBER
 - DIMENSION :
 - REEL: W=44.5, $\phi A=330$
 - SHIPPING CARTON: L=335, W=335, H=320 (INNER)
 - QUANTITY :
 - PRIMARY PACKING: 350 PCS/REEL
 - SECONDARY PACKING: 6 REELS/CARTON(2100PCS)
 - PEELING RESISTANCE: 20gf~120gf.
 - PEELING SPEED: 300mm/minutes.

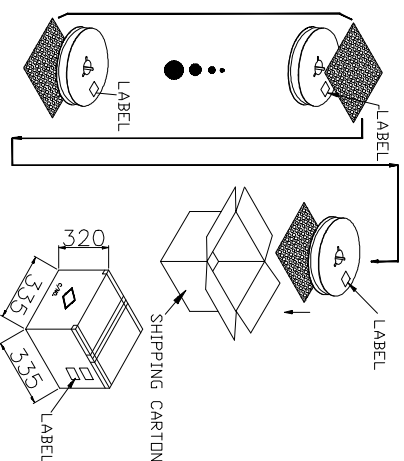

GENERAL TOLERANCES UNLESS SPECIFIED		PART NO. SEE TABLE	TITLE MINI PCI EXPRESS 9.0H 0.8PITCH 52P
X ± 0.35	X ± 3°		
XX ± 0.25	X ± 2°	APPROVED BY Barney	 Lian Xin Technology
XXX ± 0.16	XX ± 1°	CHECKED BY Raymond	
CUSTOMER DRAWING		DWG NO. AP-AAA-PCI-047	
SIZE A4	UNITS MM	DRAWN BY XU	SHEET 6 / 6 SCALE N/A REV 103