

# FAN5617

## High-Efficiency, Constant-Current LED Driver with TinyWire™ Brightness Control

### Features

- Three-Channel Parallel LED Driver for a Large Range of Forward Voltages
- TinyWire™ Single-Wire Digital Brightness Control
- 32 Static Brightness Levels with 5-Bit Internal DAC
- Adaptive  $V_{OUT}$  Adjustment to the Highest Diode Forward Voltage
- Matched LED Currents; Matched or Unmatched LEDs
- Built-in Charge Pump with Three Modes of Operation: 1x (linear), 1.5x, and 2x
- Up to 90% Efficiency
- Low EMI, Low Ripple
- Up to 90mA Total Output Current
- Drives up to Three LEDs at 30mA Each
- External Resistor Sets Maximum (100%) LED Current
- 2.7V to 5.5V Input Voltage Range
- 1MHz Operating Frequency
- Shutdown Isolates Output from Input, Typically  $<1\mu A$
- Protections: Short-Circuit; Soft-Start Limits Inrush Current
- Minimal External Components Required
- 3x3mm 16-Lead MLP Package

### Applications

- Portable Handheld Backlight
- PDAs, DVD players, Pagers, Camcorder Backlights
- Portable Medical Diagnostic Equipments Display
- MP3 Player Displays
- Digital Still Camera Backlight

### Description

The FAN5617 is a low-ripple, low-EMI, high-efficiency, constant-current LED driver that drives three LEDs in parallel. The LED brightness control is programmable through Fairchild's proprietary single-wire digital interface, TinyWire™. The charge pump DC/DC converter operates in three modes: 1X, 1.5X, and 2X over the entire input voltage range of 2.7V to 5.5V. The adaptive nature of the built-in charge pump eliminates the need for LED pre-selection (matching) and delivers high output efficiency. FAN5617 is capable of driving up to 90mA total output current, 30mA per channel. The driver's built-in, proprietary auto-sense circuit ensures the same efficiency regardless of the number of LEDs connected. When the input voltage is insufficient to sustain the LEDs programmable current level, the FAN5617 reconfigures itself to operate as a linear regulator and the charge pump circuit turns off.

The FAN5617 features Fairchild's TinyWire™ single-wire digital interface for LED brightness control. The built-in 5-bit DAC provides selection of 32 dimming levels, where each level is a percentage of the maximum LED current set by the external resistor,  $R_{SET}$ . The FAN5617 includes shutdown, short-circuit, and thermal protection circuitry.

Minimal external components are required: two bucket capacitors (2 $\mu F$  and 1 $\mu F$ ), a 4.7 $\mu F$  input capacitor, and a 1 $\mu F$  output capacitor are needed for proper operation.

The FAN5617 is available in a 3x3mm, 16-lead, molded leadless package (MLP).

### Ordering Information

| Part Number | Pb-Free | Operating Temperature Range | Package      | Packing Method |
|-------------|---------|-----------------------------|--------------|----------------|
| FAN5617MPX  | Yes     | 0°C to 85°C                 | MLP-16 3x3mm | Tape and Reel  |

TinyWire™ is a trademark of Fairchild Semiconductor Corporation.

## Application Diagram

|            |             |
|------------|-------------|
| $C_{IN}$   | 4.7 $\mu$ F |
| CAP1, CAP2 | 0.1 $\mu$ F |
| $C_{OUT}$  | 1 $\mu$ F   |
| $R_{SET}$  | 15K         |

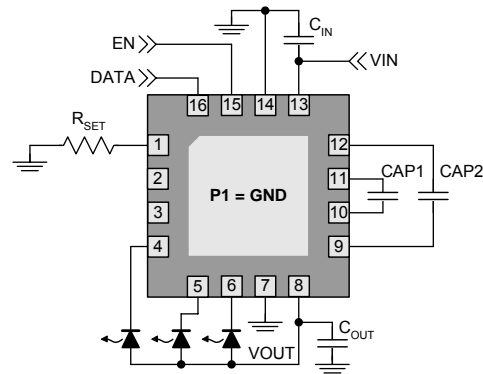

Figure 1. Typical Application

## Pin Configuration

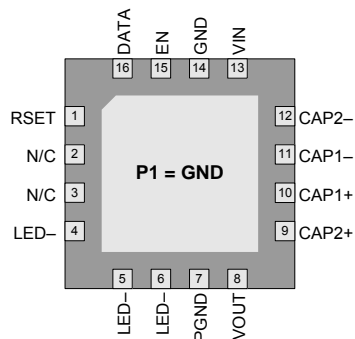

Figure 2. Top View 3x3mm MLP Package

## Pin Definitions

| Pin | Name     | Description  |
|-----|----------|--|
| 1   | RSET     | <b>Current set resistor.</b> A resistor from this pin to GND sets the maximum LED current.   |
| 2,3 | N/C      | No internal connection.  |
| 4-6 | LED-     | <b>LED cathode drive.</b>  |
| 7   | P1, PGND | <b>Power Ground</b> for the IC. Solder to PCB ground plane.  |
| 8   | VOUT     | <b>Regulated Output Voltage.</b> Connect to output capacitor and anodes of all LEDs.   |
| 9   | CAP2+    | <b>Bucket Capacitor 2.</b> Connect this pin to the positive terminal of the bucket capacitor   |
| 10  | CAP1+    | <b>Bucket Capacitor 1.</b> Connect this pin to the positive terminal of the bucket capacitor   |
| 11  | CAP1-    | <b>Bucket Capacitor 1.</b> Connect this pin to the negative terminal of the bucket capacitor   |
| 12  | CAP2-    | <b>Bucket Capacitor 2.</b> Connect this pin to the negative terminal of the bucket capacitor   |
| 13  | VIN      | <b>Supply Input Voltage.</b>   |
| 14  | GND      | <b>Ground.</b> All signals are referenced to this point. Solder to PCB ground plane.   |
| 15  | EN       | <b>Enable.</b> Enables the IC when high and disables at HIGH-to-LOW transition. The TinyWire control overrides the state of the EN pin if a command is received. |
| 16  | DATA     | <b>DATA input</b> for TinyWire brightness control. This pin has a 33k $\Omega$ internal pull-up resistor to $V_{IN}$ .   |

## Absolute Maximum Ratings

Stresses exceeding the absolute maximum ratings may damage the device. The device may not function or be operable above the recommended operating conditions and stressing the parts to these levels is not recommended. In addition, extended exposure to stresses above the recommended operating conditions may affect device reliability. The absolute maximum ratings are stress ratings only.

| Parameter   | Min. | Max.                 | Units |
|---|------|----------------------|-------|
| V <sub>IN</sub> , V <sub>OUT</sub> , EN, DATA, GND                    | -0.3 | 6                    | V     |
| Voltage on All Other Pins   | -0.3 | V <sub>IN</sub> +0.3 | V     |
| CAP+, CAP- to GND   | -0.3 | V <sub>IN</sub> +0.3 | V     |
| Thermal Resistance – Junction to Tab ( $\theta_{JC}$ ) <sup>(1)</sup> |      | 8                    | °C/W  |
| Lead Soldering Temperature (10 seconds)                               |      | 260                  | °C    |
| Junction Temperature  |      | 150                  | °C    |
| Storage Temperature   | -65  | 150                  | °C    |
| Electrostatic Discharge (ESD) Protection Level <sup>(2)</sup>         | HBM  | 4.0                  | kV    |
|   | CDM  | 2.0                  | kV    |

### Notes:

- Junction-to-ambient thermal resistance,  $\theta_{JA}$ , is a strong function of PCB material, board thickness, copper thickness and number of vias used, diameter of via used, available copper surface, and attached heat sink characteristics. A reasonable estimated value for  $\theta_{JA}$  for zero air flow at 0.5W is 60°C/W.
- Using Mil Std. 883E, method 3015.7 (Human Body Model) and EIA/JESD22C101-A (Charged Device Model).

## Recommended Operating Conditions

The Recommended Operating Conditions table defines the conditions for actual device operation. Recommended operating conditions are specified to ensure optimal performance to the datasheet specifications. Fairchild does not recommend exceeding them or designing to absolute maximum ratings.

| Parameter                      | Min. | Max. | Units |
|--------------------------------|------|------|-------|
| Supply Voltage Range           | 2.5  | 5.5  | V     |
| LED Forward Voltage            |      | 4    | V     |
| Current Through Each LED       | 2    | 30   | mA    |
| Operating Ambient Temperature  | -40  | +85  | °C    |
| Operating Junction Temperature | -40  | +125 | °C    |

## Electrical Specifications

Unless otherwise noted,  $V_{IN} = 2.7V$  to  $5.5V$ ,  $I_{LED} = 2mA$  to  $20mA$ ,  $EN = HIGH$ ,  $N_{BR} = 31$ ,  $T_A = -40^{\circ}C$  to  $+85^{\circ}C$ . Typical values are at  $25^{\circ}C$ .

| Parameter   | Conditions   | Min. | Typ. | Max. | Units       |
|---|--|------|------|------|-------------|
| <b>Power Supplies</b>                               |  |      |      |      |             |
| Input Under-Voltage Lockout                         | $V_{IN}$ Falling   |      |      | 1.6  | V           |
|   | $V_{IN}$ Rising  | 2.3  |      |      | V           |
| Current Matching with Unmatched LEDs <sup>(3)</sup> | $2mA \leq I_{LED} \leq 15mA$ ,<br>$2.8V \leq LED V_F < 4V$ |      | 0.6  | +3   | %           |
| $I_{LED}/I_{SET}$ Ratio                             | $V_{IN} = 3.6V$ , $I_{OUT} = 15mA$                         | 245  | 260  | 275  |             |
|   | $I_{LED} = 2$ to $20mA$                                    | 230  | 260  | 280  |             |
| Reference Voltage for Current Set                   |  | 588  | 600  | 612  | mV          |
| Start-up Time <sup>(4)</sup>                        | $C_{OUT} = 1\mu F$ , $V_{IN} = 3.6V$ , $I_{LED} = 15mA$    | 200  | 270  | 500  | $\mu S$     |
| Minimum Cathode Voltage                             | $I_{LED} = 15mA$   |      | 170  | 250  | mV          |
| Quiescent Current                                   | $V_{IN} = 5.5V$ , $I_{OUT} = 5mA$                          |      | 250  |      | $\mu A$     |
| Shutdown Supply Current                             | $EN=0V$ , $DATA_{IN} = V_{IN}$ <sup>(5)</sup>              |      | 0.1  | 1    | $\mu A$     |
| Output Short-Circuit Current                        | $V_{IN} = 5.5V$ , $V_{OUT} = 0V$                           |      | 65   | 80   | mA          |
| $V_{OUT}$ Over-Voltage Protection                   |  |      |      | 6    | V           |
| $V_{IN}$ at Mode Transition from 1x to 1.5x         | $LED V_f = 3.5V$ , $I_{LED} = 3 \times 20mA$               |      | 3.9  |      | V           |
| $V_{IN}$ at Mode Transition from 1.5x to 2x         | $LED V_f = 3.5V$ , $I_{LED} = 3 \times 20mA$               |      | 2.9  |      | V           |
| Peak Efficiency <sup>(6)</sup>                      | $V_{IN} = 3.75V$ , $LED V_f = 3.4V$ ,<br>$I_{LED} = 18mA$  |      | 90   |      | %           |
| Oscillator Frequency                                |  | 0.8  | 1    | 1.2  | MHz         |
| Thermal Shutdown Threshold                          |  |      | 150  |      | $^{\circ}C$ |
| Thermal Shutdown Hysteresis                         |  |      | 15   |      | $^{\circ}C$ |
| <b>Logic Input Thresholds (EN and DATA)</b>         |  |      |      |      |             |
| Input Low Voltage                                   |  |      |      | 0.4  | V           |
| Input High Voltage                                  |  | 1.25 |      |      | V           |
| DATA Input Low Current                              | $V_{IN} = 3.6V$  |      | 110  |      | $\mu A$     |

### Notes:

3. Current Matching refers to the absolute value of the difference in the current between the two LED branches:

$$\text{Current Matching (\%)} = \left| \frac{(I_{LEDi} - I_{LEDj}) \times 100}{(I_{LEDi} + I_{LEDj})} \right| \text{ where } i, j = 1, 2, \text{ or } 3.$$

4. Start-up time is defined as the period from when the driver is turned on to the time when  $I_{LED}$  is within 10% of its programmed value.
5. When DATA remains low, the TinyWire interface is biased on and consumes up to  $30\mu A$  of current.
6. Efficiency is expressed as a ratio between the electrical power into the LEDs and the total power consumed from the input power supply, expressed as:

$$\text{Efficiency} = \frac{\sum_{i=1}^3 V_{LEDi} \times I_{LEDi}}{V_{IN} \times I_{IN}}$$

Some vendors calculate the efficiency as a function of  $V_{OUT}$  instead of LED VF. That method does not account for the power lost due to the cathode voltage not being equal to zero, which overstates efficiency by up to 5%.

## Typical Characteristics

Unless otherwise noted,  $V_{IN} = 3.6V$ ,  $T_A = 25^\circ C$ ,  $C_{IN} = 4.7\mu F$ ,  $C_{OUT} = 1\mu F$ ,  $CAP1 = CAP2 = 0.1\mu F$ , the FAN5617 driving three LEDs with  $V_F = 3.3V$  at 20mA.

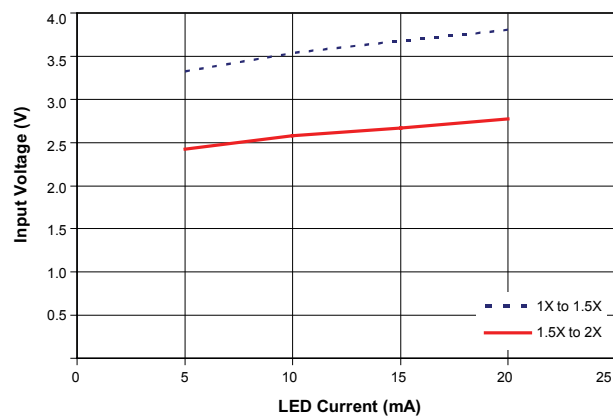

**Figure 3. Voltage Multiplication Ratio vs. LED Current**

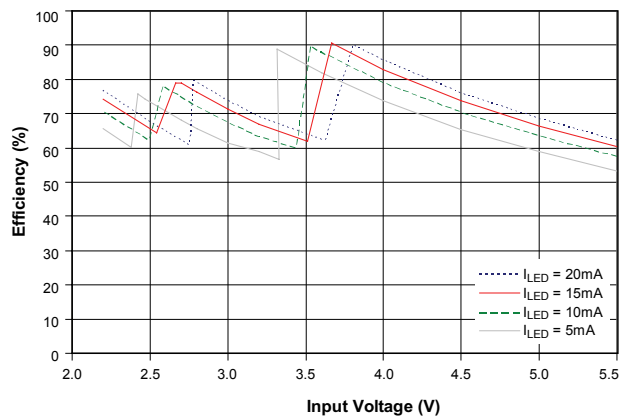

**Figure 4. Efficiency vs. Input Voltage**

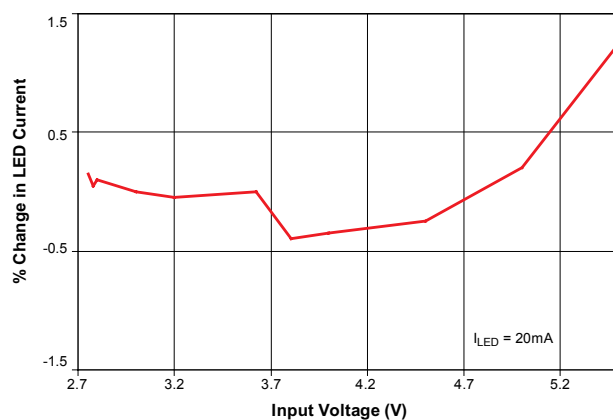

**Figure 5. LED current vs. Input Voltage**

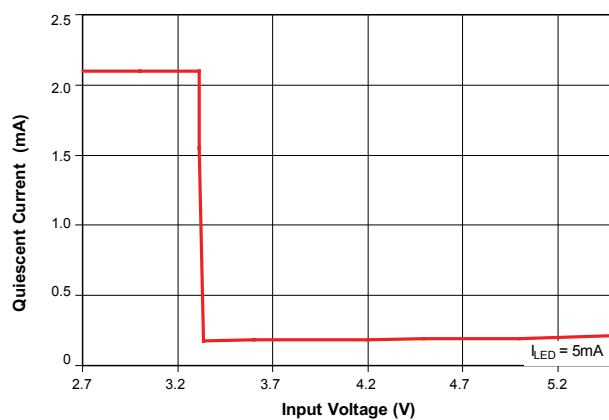

**Figure 6. Quiescent Current vs. Input Voltage**

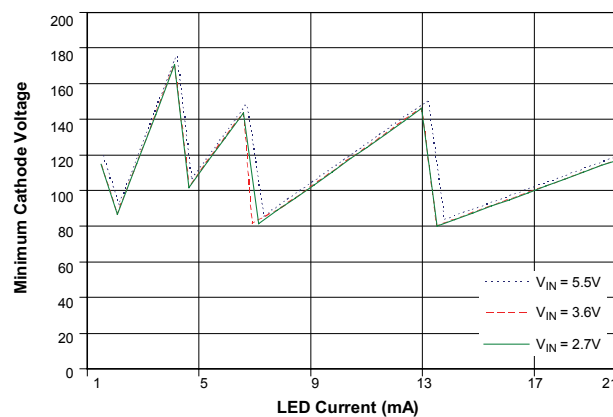

**Figure 7. Minimum Cathode Voltage**

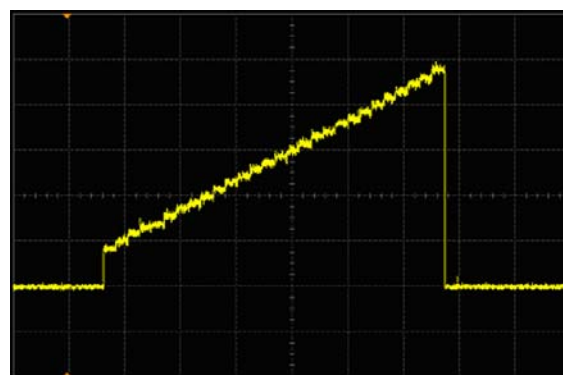

**Figure 8. Dimming Linearity**

### Block Diagram

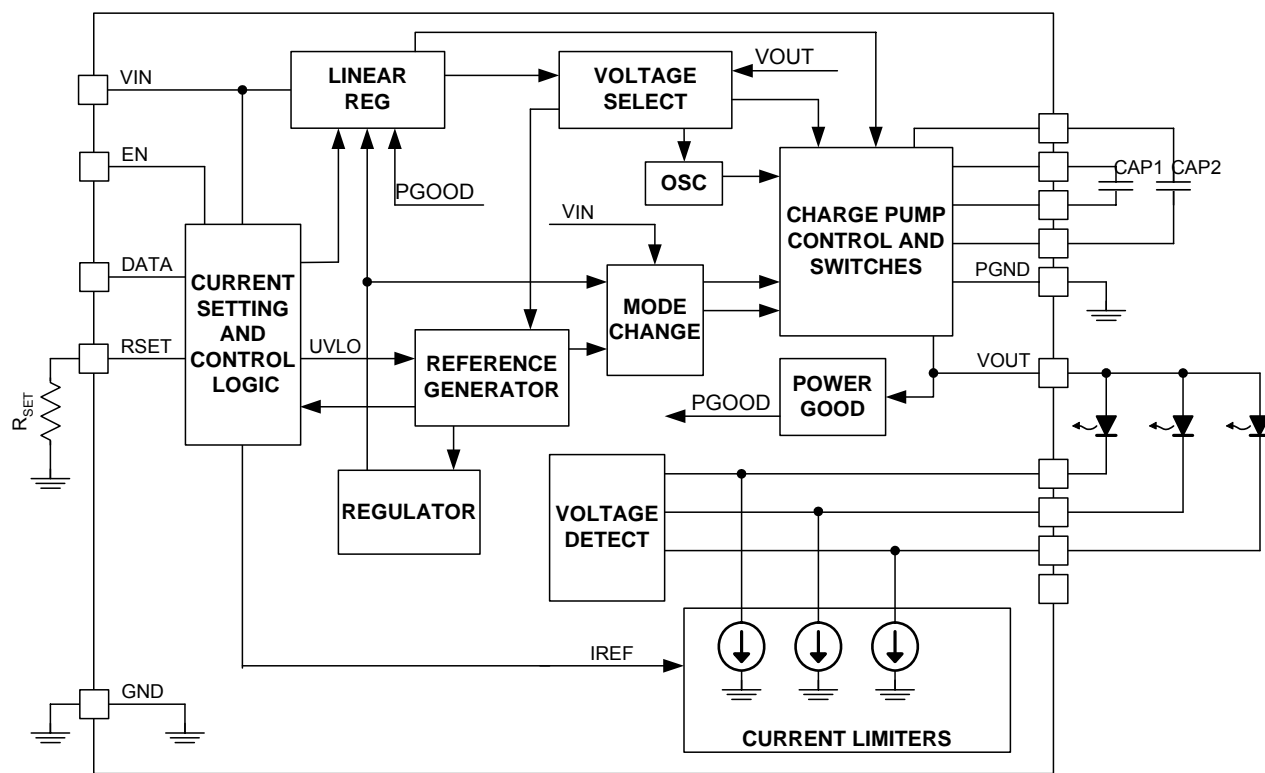

Figure 9. IC Block Diagram

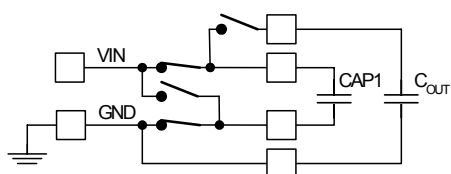

Figure 10. 2:1 Charge Pump Configuration  
 $V_{OUT} = 2 \times V_{IN}$

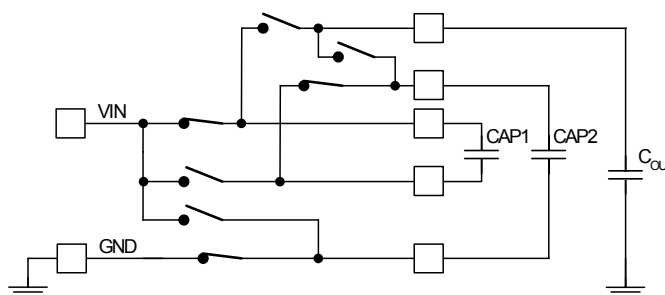

Figure 11. 3:2 Charge Pump Configuration  
 $V_{OUT} = 1.5 \times V_{IN}$

## Circuit Description

The FAN5617 switch capacitor DC/DC converter automatically configures its internal switches to achieve high efficiency, providing tightly-regulated output currents for the LEDs (see Figure 10 and Figure 11).

An internal voltage detector determines which LED requires the highest voltage to sustain the pre-set current levels and adjusts the charge pump regulator accordingly. Each LED has its own linear current regulator. In addition, a voltage regulator controls the output voltage when the battery voltage is within a range where linear regulation can provide maximum efficiency. If the battery voltage is too low to sustain the LED current in linear mode, a fractional 3:2 charge pump is enabled. When the battery voltage drops and the mode can no longer sustain proper operation, the pump is automatically reconfigured to operate in 2:1 mode. As the battery discharges and the voltage decays, the FAN5617 switches between modes to maintain a constant current through the LEDs throughout the battery life. These transitions have hysteresis to prevent toggling.

The internal supply voltage of the device is automatically selected from the VIN or VOUT pins, whichever has a higher voltage.

The FAN5617 enters shutdown mode to reduce overall current consumption when the chip is disabled by the EN pin and control register.

### Start-up

When the FAN5617 is enabled, either by EN going high or on command from the TinyWire™ interface, the soft-start circuit linearly ramps V<sub>OUT</sub> to limit the switcher's inrush current (see Figure 12). When power is first applied, the default IC brightness control register (N<sub>BR</sub>) is set to maximum brightness (31). If EN is low at initial power-up, the IC remains in a low-power state until either EN goes HIGH or a non-0 brightness command is received. If EN goes from HIGH to LOW, the IC is reset to the low-power state until either a new brightness command is received or EN is driven HIGH.

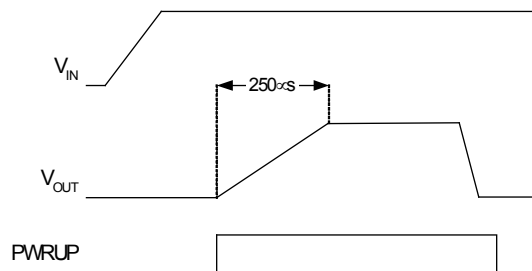

**Figure 12. Soft-Start**

An internal PWRUP signal turns on all of the IC's logic control circuitry and starts the charge pump. PWRUP is high under any of the following conditions:

1. EN goes from low to high
2. A non-zero brightness command is received

PWRUP goes low under any of the following conditions:

1. EN is low when power is first applied and no subsequent non-zero brightness commands are received
2. EN goes from HIGH to LOW
3. A zero brightness command is received

### TinyWire™ Single-Wire Brightness Control

This IC features a digitally controlled static brightness adjustment to minimize both EMI and applications processor overhead. The brightness command consists of a 5-bit binary word (N<sub>BR</sub>). LED current is a multiple of the current through R<sub>SET</sub>:

$$I_{LED} = \frac{156 \cdot (N_{BR} + 1)}{32 \cdot R_{SET}} \quad \text{for } N_{BR} > 0 \quad (1)$$

| N <sub>BR</sub> | BIT4 | BIT3 | BIT2 | BIT1 | BIT0 | I <sub>LED</sub> /I <sub>SET</sub> |
|-----------------|------|------|------|------|------|------------------------------------|
| 0               | 0    | 0    | 0    | 0    | 0    | 0                                  |
| 1               | 0    | 0    | 0    | 0    | 1    | 260 × 2/32                         |
| 2               | 0    | 0    | 0    | 1    | 0    | 260 × 3/32                         |
| 3               | 0    | 0    | 0    | 1    | 1    | 260 × 4/32                         |
| 4               | 0    | 0    | 1    | 0    | 0    | 260 × 5/32                         |
| 5               | 0    | 0    | 1    | 0    | 1    | 260 × 6/32                         |
| 6               | 0    | 0    | 1    | 1    | 0    | 260 × 7/32                         |
| 7               | 0    | 0    | 1    | 1    | 1    | 260 × 8/32                         |
| 8               | 0    | 1    | 0    | 0    | 0    | 260 × 9/32                         |
| 9               | 0    | 1    | 0    | 0    | 1    | 260 × 10/32                        |
| 10              | 0    | 1    | 0    | 1    | 0    | 260 × 11/32                        |
| 11              | 0    | 1    | 0    | 1    | 1    | 260 × 12/32                        |
| 12              | 0    | 1    | 1    | 0    | 0    | 260 × 13/32                        |
| 13              | 0    | 1    | 1    | 0    | 1    | 260 × 14/32                        |
| 14              | 0    | 1    | 1    | 1    | 0    | 260 × 15/32                        |
| 15              | 0    | 1    | 1    | 1    | 1    | 260 × 16/32                        |
| 16              | 1    | 0    | 0    | 0    | 0    | 260 × 17/32                        |
| 17              | 1    | 0    | 0    | 0    | 1    | 260 × 18/32                        |
| 18              | 1    | 0    | 0    | 1    | 0    | 260 × 19/32                        |
| 19              | 1    | 0    | 0    | 1    | 1    | 260 × 20/32                        |
| 20              | 1    | 0    | 1    | 0    | 0    | 260 × 21/32                        |
| 21              | 1    | 0    | 1    | 0    | 1    | 260 × 22/32                        |
| 22              | 1    | 0    | 1    | 1    | 0    | 260 × 23/32                        |
| 23              | 1    | 0    | 1    | 1    | 1    | 260 × 24/32                        |
| 24              | 1    | 1    | 0    | 0    | 0    | 260 × 25/32                        |
| 25              | 1    | 1    | 0    | 0    | 1    | 260 × 26/32                        |
| 26              | 1    | 1    | 0    | 1    | 0    | 260 × 27/32                        |
| 27              | 1    | 1    | 0    | 1    | 1    | 260 × 28/32                        |
| 28              | 1    | 1    | 1    | 0    | 0    | 260 × 29/32                        |
| 29              | 1    | 1    | 1    | 0    | 1    | 260 × 30/32                        |
| 30              | 1    | 1    | 1    | 1    | 0    | 260 × 31/32                        |
| 31              | 1    | 1    | 1    | 1    | 1    | 260 × 32/32                        |

**Table 1. N<sub>BR</sub> Data Dimming Values**

## Circuit Description (Continued)

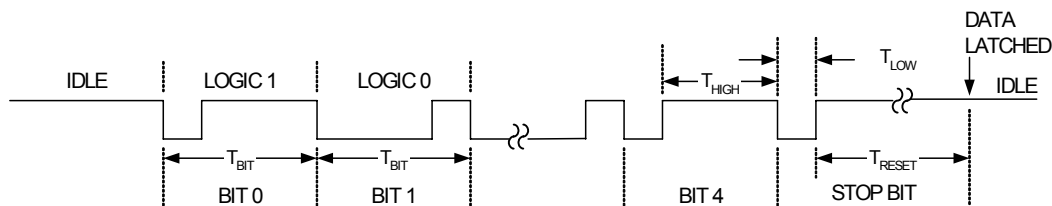

Figure 13. TinyWire™ Protocol Timing

$N_{BR}$  data is shifted in LSB first on the DATA line, as shown in Figure 13. The TinyWire protocol operates over a wide range of  $T_{BIT}$  times (see Table 3), allowing easy encoding of the brightness control bit-stream using a microcontroller software “bit-bang” loop.

The 5-bit control word begins with the falling edge of DATA. If DATA is HIGH for a greater percentage of the time than it is low between falling edges, the bit is a “1.” If DATA is LOW longer than it is HIGH, the bit is a “0.” Observe the following timing rules to ensure proper data transmission:

| BIT = | $T_{LOW}$           | $T_{HIGH}$          |
|-------|---------------------|---------------------|
| 0     | $\geq 75\% T_{BIT}$ | $\leq 25\% T_{BIT}$ |
| 1     | $\leq 25\% T_{BIT}$ | $\geq 75\% T_{BIT}$ |

Table 2. Data Bit Definition

|             | MIN.        | MAX.       |
|-------------|-------------|------------|
| $T_{LOW}$   | 500ns       | 40 $\mu$ s |
| $T_{HIGH}$  | 500ns       | 40 $\mu$ s |
| $T_{RESET}$ | 100 $\mu$ s |            |

Table 3. Timing Requirements

| Time | BIT = | $T_{LOW}$  | $T_{HIGH}$ | $T_{BIT}$  |
|------|-------|------------|------------|------------|
| MIN. | 0     | 1500ns     | 500ns      | 2 $\mu$ s  |
| MAX. | 0     | 40 $\mu$ s | 13 $\mu$ s | 53 $\mu$ s |
| MIN. | 1     | 500ns      | 1500ns     | 2 $\mu$ s  |
| MAX. | 1     | 13 $\mu$ s | 40 $\mu$ s | 53 $\mu$ s |

Table 4. Minimum and Maximum Bit Times

Each falling edge of DATA clocks in the value of its preceding bit, necessitating a STOP pulse of at least  $T_{LOW(MIN)}$  width. The command word,  $N_{BR}$  (see Table 1. *NBR Data Dimming Values*), transfers to the internal registers and is valid at the rising edge of the STOP bit. A RESET is generated to the internal bit counters after the DATA line remains high for at least 100 $\mu$ s. If less than five bits are received before the RESET occurs, no new data is transferred to the internal registers. If more than five bits are received before RESET, the first five bits are transferred at the rising edge of the sixth bit and subsequent bits are ignored.

## Short-Circuit and Thermal Protection

In the event of an output voltage short circuit, the output current is limited to a typical value of 65mA.

In addition, when the die temperature exceeds 150°C, a reset occurs and remains in effect until the die cools down to 135°C; at which time, the circuit restarts and resumes normal operation.

## Selecting Capacitors

It is important to select the appropriate capacitor types and values for the FAN5617 circuit design. To reduce battery ripple, both  $C_{IN}$  and  $C_{OUT}$  should be low-ESR capacitors. If necessary, the ripple can be further reduced by powering the IC through an RC input filter, as shown in Figure 14.

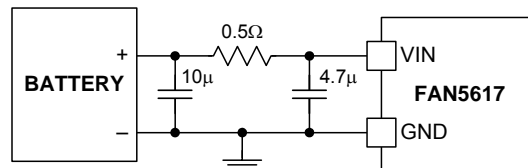

Figure 14. Battery Ripple Reduction

CAP1 and CAP2 should be MLCC capacitors of 0.1 $\mu$ F to 1 $\mu$ F for best efficiency in boost mode. For better  $I_{LED}$  regulation, 1 $\mu$ F bucket capacitors are recommended, particularly when  $I_{LED} > 25$ mA and the battery discharges below 3V.

## PCB Layout Considerations

For best performance, a solid ground plane is recommended on the back side of the PCB. All capacitors should be placed as close to the IC as possible and connected with reasonably thick traces to minimize the ESL and ESR parasitics.



## Physical Dimensions

Dimensions are in millimeters (inches) unless otherwise noted.

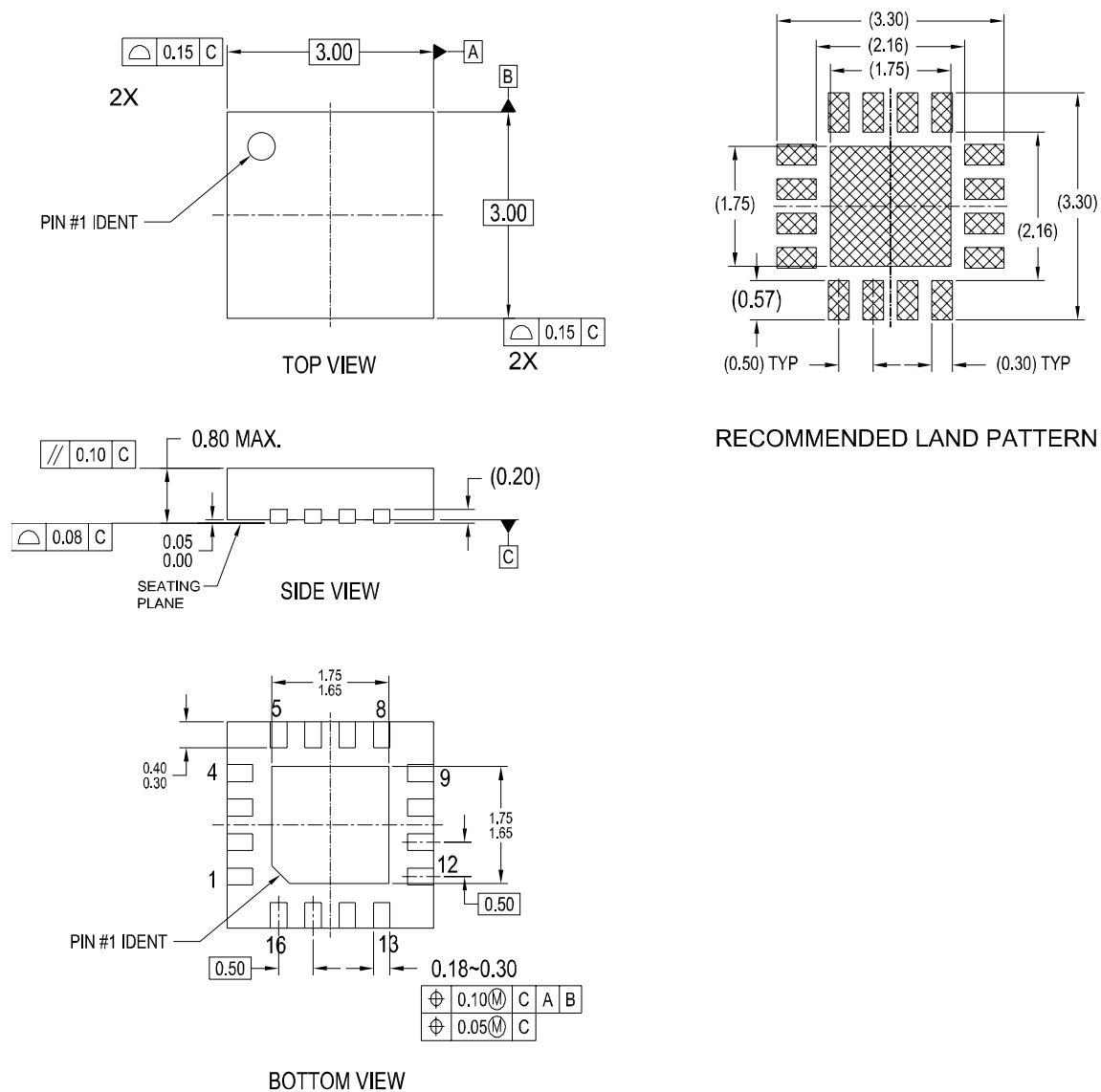

### NOTES:

- A. CONFORMS TO JEDEC REGISTRATION MO-220, VARIATION WEED-Pending, DATED pending
- B. DIMENSIONS ARE IN MILLIMETERS.
- C. DIMENSIONS AND TOLERANCES PER ASME Y14.5M, 1994
- D. DIMENSIONS ARE EXCLUSIVE OF BURS, MOLD FLASH, AND TIE BAR EXTRUSIONS.

MLP16BrevB

**Figure 15. 16-Lead, Molded Leadless Package (MLP), 3 x 3mm, .8mm Thick**



### TRADEMARKS

The following are registered and unregistered trademarks Fairchild Semiconductor owns or is authorized to use and is not intended to be an exhaustive list of all such trademarks.

|  |                                |   |                             |
|--|--------------------------------|---|-----------------------------|
| ACE <sup>®</sup>                                 | <i>i-Lo</i> <sup>™</sup>       | Power-SPM <sup>™</sup>  | TinyBoost <sup>™</sup>      |
| Across the board. Around the world. <sup>™</sup> | ImpliedDisconnect <sup>™</sup> | PowerTrench <sup>®</sup>  | TinyBuck <sup>™</sup>       |
| ActiveArray <sup>™</sup>                         | IntelliMAX <sup>™</sup>        | Programmable Active Droop <sup>™</sup>  | TinyLogic <sup>®</sup>      |
| Bottomless <sup>™</sup>                          | ISOPLANAR <sup>™</sup>         | QFET <sup>®</sup>   | TINYOPTO <sup>™</sup>       |
| Build it Now <sup>™</sup>                        | MICROCOUPLER <sup>™</sup>      | QS <sup>™</sup>   | TinyPower <sup>™</sup>      |
| CoolFET <sup>™</sup>                             | MicroPak <sup>™</sup>          | QT Optoelectronics <sup>™</sup>   | TinyWre <sup>™</sup>        |
| CROSSVOLT <sup>™</sup>                           | MICROWIRE <sup>™</sup>         | Quiet Series <sup>™</sup>   | TruTranslation <sup>™</sup> |
| CTL <sup>™</sup>                                 | Motion-SPM <sup>™</sup>        | RapidConfigure <sup>™</sup>   | μSerDes <sup>™</sup>        |
| Current Transfer Logic <sup>™</sup>              | MSX <sup>™</sup>               | RapidConnect <sup>™</sup>   | UHC <sup>®</sup>            |
| DOME <sup>™</sup>                                | MSXPro <sup>™</sup>            | ScalarPump <sup>™</sup>   | UniFET <sup>™</sup>         |
| E <sup>2</sup> CMOS <sup>™</sup>                 | OCX <sup>™</sup>               | SMART START <sup>™</sup>  | VCX <sup>™</sup>            |
| EcoSPARK <sup>®</sup>                            | OCXPro <sup>™</sup>            | SPM <sup>®</sup>  | Wire <sup>™</sup>           |
| EnSigna <sup>™</sup>                             | OPTOLOGIC <sup>®</sup>         | STEALTH <sup>™</sup>  |                             |
| FACT Quiet Series <sup>™</sup>                   | OPTOPLANAR <sup>®</sup>        | SuperFET <sup>™</sup>   |                             |
| FACT <sup>®</sup>                                | PACMAN <sup>™</sup>            | SuperSOT <sup>™</sup> -3  |                             |
| FAST <sup>®</sup>                                | PDP-SPM <sup>™</sup>           | SuperSOT <sup>™</sup> -6  |                             |
| FASTr <sup>™</sup>                               | POP <sup>™</sup>               | SuperSOT <sup>™</sup> -8  |                             |
| FPST <sup>™</sup>                                | Power220 <sup>®</sup>          | SyncFET <sup>™</sup>  |                             |
| FRFET <sup>®</sup>                               | Power247 <sup>®</sup>          | TCM <sup>™</sup>  |                             |
| GlobalOptoisolator <sup>™</sup>                  | PowerEdge <sup>™</sup>         | The Power Franchise <sup>®</sup>  |                             |
| GTO <sup>™</sup>                                 | PowerSaver <sup>™</sup>        |  |                             |
| HiSeC <sup>™</sup>                               |                                |   |                             |

### DISCLAIMER

FAIRCHILD SEMICONDUCTOR RESERVES THE RIGHT TO MAKE CHANGES WITHOUT FURTHER NOTICE TO ANY PRODUCTS HEREIN TO IMPROVE RELIABILITY, FUNCTION OR DESIGN. FAIRCHILD DOES NOT ASSUME ANY LIABILITY ARISING OUT OF THE APPLICATION OR USE OF ANY PRODUCT OR CIRCUIT DESCRIBED HEREIN; NEITHER DOES IT CONVEY ANY LICENSE UNDER ITS PATENT RIGHTS, NOR THE RIGHTS OF OTHERS. THESE SPECIFICATIONS DO NOT EXPAND THE TERMS OF FAIRCHILD'S WORLDWIDE TERMS AND CONDITIONS, SPECIFICALLY THE WARRANTY THEREIN, WHICH COVERS THESE PRODUCTS.

### LIFE SUPPORT POLICY

FAIRCHILD'S PRODUCTS ARE NOT AUTHORIZED FOR USE AS CRITICAL COMPONENTS IN LIFE SUPPORT DEVICES OR SYSTEMS WITHOUT THE EXPRESS WRITTEN APPROVAL OF FAIRCHILD SEMICONDUCTOR CORPORATION.

As used herein:

1. Life support devices or systems are devices or systems which, (a) are intended for surgical implant into the body or (b) support or sustain life, and (c) whose failure to perform when properly used in accordance with instructions for use provided in the labeling, can be reasonably expected to result in a significant injury of the user.
2. A critical component in any component of a life support, device, or system whose failure to perform can be reasonably expected to cause the failure of the life support device or system, or to affect its safety or effectiveness.

### PRODUCT STATUS DEFINITIONS

#### Definition of Terms

| Datasheet Identification | Product Status         | Definition   |
|--------------------------|------------------------|--|
| Advance Information      | Formative or In Design | This datasheet contains the design specifications for product development. Specifications may change in any manner without notice.   |
| Preliminary              | First Production       | This datasheet contains preliminary data; supplementary data will be published at a later date. Fairchild Semiconductor reserves the right to make changes at any time without notice to improve design. |
| No Identification Needed | Full Production        | This datasheet contains final specifications. Fairchild Semiconductor reserves the right to make changes at any time without notice to improve design.   |
| Obsolete                 | Not In Production      | This datasheet contains specifications on a product that has been discontinued by Fairchild Semiconductor. The datasheet is printed for reference information only.                                      |

Rev. 126