

FAN5608 Serial / Parallel LED Driver with Current-Regulated, Step-Up DC/DC Converter

Features

- Two independent channels drive up to six LEDs per channel
- Adaptive output voltage drive to maximize efficiency
- PFM mode of operation of the boost circuit
- Up to 85% efficiency
- Up to 2×20mA output
- Two built-in DACs for independent (digital) brightness control for both channels
- LED current can be duty-cycle-modulated, 0 to 20mA
- Digital, analog, and PWM brightness control
- 2.7V to 5.5V input voltage range
- 500KHz operating frequency
- Soft-start feature
- Low shutdown current: $I_{CC} < 1\mu A$
- Open-load protection
- Minimal external components needed
- Space-saving 4x4mm 12-lead MLP packages

Applications

- Cell phones
- Handheld computers
- PDAs, DSCs, MP3 players
- Keyboard backlights
- LED displays

Description

The FAN5608 is an integrated Schottky diode LED driver, which generates regulated output currents from a battery input voltage of 2.7V to 5V. An internal MOS switch and the external inductor deliver the necessary voltage to the load. The proprietary internal compensation loop continuously monitors the lowest LED cathode voltage of both channels and adjusts the V_{OUT} voltage to the minimum value. The minimum V_{OUT} is determined by the highest LED forward voltage of the selected channel. This adaptive nature allows the FAN5608 architecture to deliver high efficiency. Up to twelve LEDs can be connected in series as long as the summed forward voltage does not exceed the maximum specification of 24V. It is not required to match an equal number of LEDs serially within each channel; FAN5608 delivers the highest efficiency and best current regulation in the balanced configuration.

FAN5608 has two internal two-bit D/A converters that provide independent programmability to each output channel. In analog programming, "B" pins must be GND (logic "0"); a resistor must be connected between pin "A" and a fixed supply voltage. The output current can be programmed to any desired value within the specified range. The FAN5608DHMPX is available in a 4x4mm 12-lead MLP package. A single external resistor sets the current and turns the device ON and OFF.

Ordering Information

Part Number	Pb-Free	Schottky Diode	Package	Packing Method
FAN5608DHMPX	Yes	Internal	MLP-12 4x4mm	Tape and Reel

Block Diagram

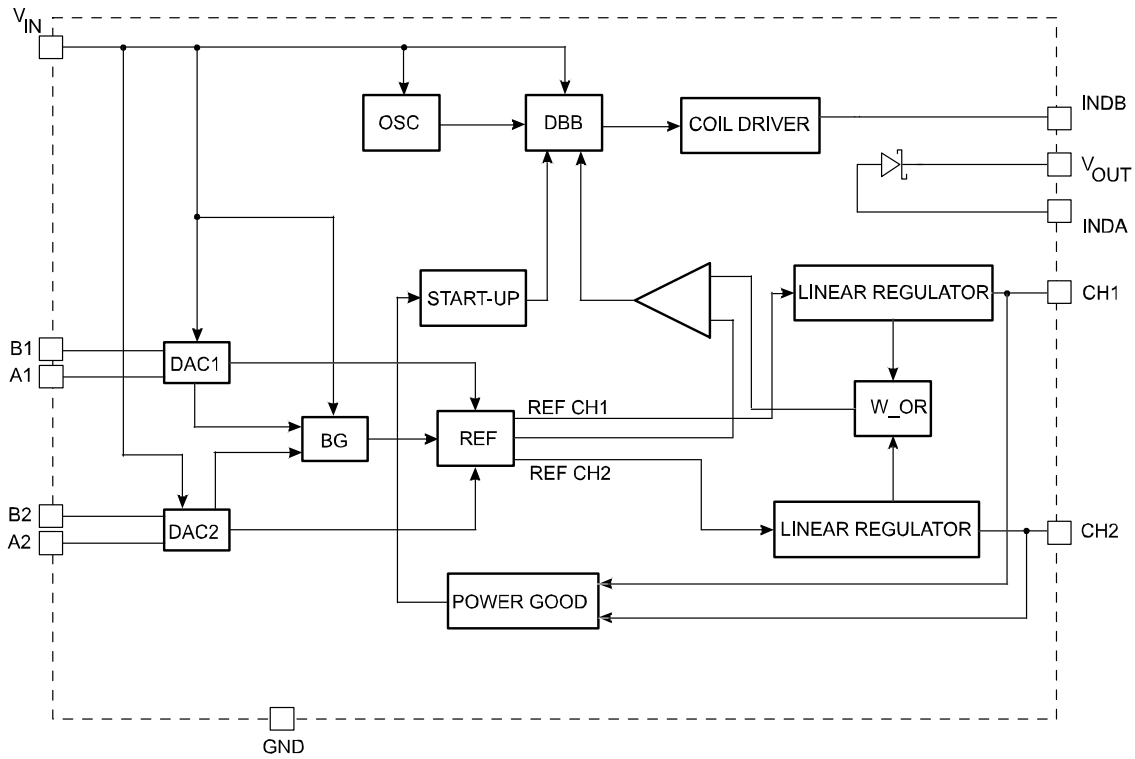
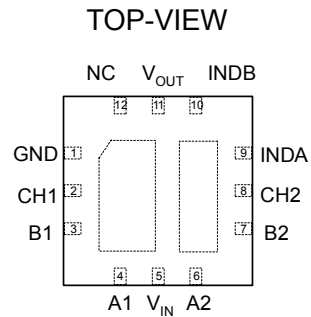

Figure 1. Block Diagram

Pin Configuration



4x4mm 12-Lead MLP(QUAD)
(Internal Schottky Diode)

FAN5608DHMPX

Figure 2. FAN5608M MLP package

Pin Definitions

Pin #	Name	Description
1	GND	Ground
2	CH1	First LED Cathode
3	B1	DAC B1
4	A1	DAC A1
5	VIN	Input Voltage
6	A2	DAC A2
7	B2	DAC B2
8	CH2	Second LED Cathode
9	INDA	SD Anode. INDA and INDB must be connected together externally on the PCB.
10	INDB	Inductor. INDA and INDB must be connected together externally on the PCB.
11	VOUT	Output LEDs Anode
12	NC	No Connection

Absolute Maximum Ratings

The "Absolute Maximum Ratings" are those values beyond which the safety of the device cannot be guaranteed. The device should not be operated at these limits. The parametric values defined in the Electrical Characteristics tables are not guaranteed at the absolute maximum ratings. The "Recommended Operating Conditions" table defines the conditions for actual device operation.

Parameter	Min.	Max.	Units
V _{IN} to GND	-0.3	6.5	V
V _{OUT} to GND	-0.3	35	V
CH1,CH2 Voltage to GND		25	V
All Other Pins	-0.3	V _{IN} +0.3	V
Junction Temperature (T _J)	-20	150	°C
Storage Temperature	-65	150	°C
Lead Soldering Temperature, 10 seconds		300	°C
Electrostatic Discharge Protection ^(1,2)	HBM	1.5	kV
	CDM	2	

Notes:

- Using Mil Std. 883E, method 3015.7 (Human Body Model) and EIA/JESD22C101-A (Charge Device Model).
- Avoid positive polarity ESD stress at the cathode of the internal Schottky diode (Schottky diode cathode <1.5kV).

Recommended Operating Conditions

Parameter	Conditions	Min.	Typ.	Max.	Units
Supply Voltage V _{IN}	P _{OUT} <0.6W, 2 channels evenly loaded	2.7		5.5	V
Output Voltage Range		V _{IN}		24	V
Ambient Temperature (T _A)		-40	25	85	°C

Typical Application

Digital Brightness Control

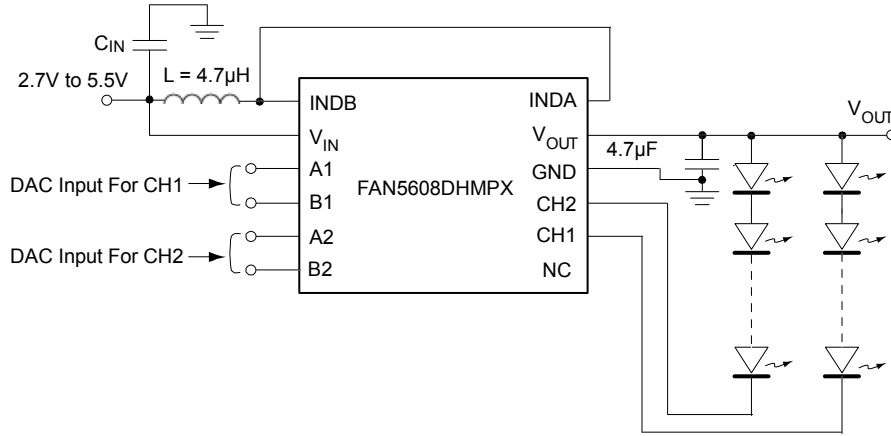

Figure 3. FAN5608 Digital Brightness Circuit

Analog Brightness Control

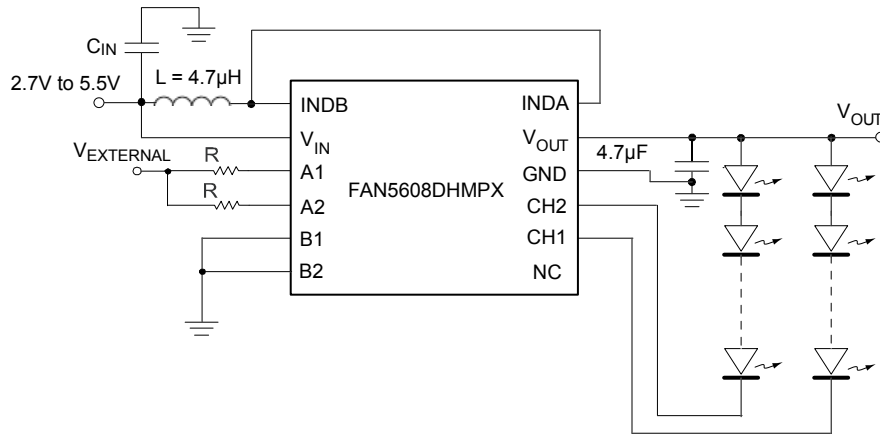

Figure 4. FAN5608 Analog Brightness Circuit

Electrical Specifications

Recommended operating conditions and component values are per the Figure 18 test circuit. Typical values are at 25°C and $V_{IN}=3.6V$. **Boldface** indicates specifications over ambient operating temperature (-40°C to +85°C).

Parameter	Conditions	Min.	Typ.	Max.	Units	
Supply current in OFF mode	A input LOW, B input LOW		0.1	1	μA	
LED current accuracy	A input HIGH, B input HIGH	18	20	22	mA	
Current matching ⁽³⁾	A input HIGH, B input HIGH			3	%	
Switching frequency			500		KHz	
Internal reference voltage, V_A	Analog Control Mode		1.2		V	
Current multiplication ratio		850	1000	1150		
Power efficiency (AVG) ⁽⁴⁾	$V_{IN} > 3V$		80		%	
Input A1, A2 threshold	Digital Control Mode	HIGH	$V_{IN} - 0.7$	V_{IN}	V	
		LOW	0	0.6		
	Analog Control Mode		1.2			
Input B1, B2 threshold	Digital Control Mode	HIGH	$0.6 \times V_{IN}$	V_{IN}	V	
		LOW	0	$0.3 \times V_{IN}$		
Input A1, A2 current	Digital Control Mode	$V_A = V_{IN}$		50	80	μA
		$V_A = 0$			0.1	
Input B1, B2 current	Digital Control Mode			0.1	μA	

Notes:

- Current matching is the absolute value of the difference in current of the two LEDs channels, divided by the average current in the two channels.
- Power efficiency is the ratio between the electrical power to the LEDs and the total power consumed from the input power supply. Although this definition leads to a lower value than the boost converter efficiency, it more accurately reflects the system performance in an application.

Circuit Description

When power is applied to the V_{IN} pin, the system is enabled, the bandgap reference acquires its nominal voltage (1.2V), and the soft-start cycle begins. Once “power good” is achieved (when 0.5mA voltage flows through the LEDs), the soft-start cycle stops, and the boost voltage increases to generate the current selected by the input control pins (A1, A2, B1, B2).

If CH1 is not selected, the CH1 output pin is HIGH, its output measurement is approximately equal to V_{OUT} , and its LEDs are OFF. The FAN5608 provides tightly regulated output currents for the selected LED's channel. An internal feedback loop determines which LED string requires the highest output voltage to sustain the pre-set current. It also adjusts the boost regulator based on CH1 and CH2 feedback voltage and A1, A2, B1, B2 input settings. System efficiency decreases if the channels' strings of LEDs have different forward voltage.

If one channel is used, the other channel should be disabled by connecting the corresponding DAC inputs to logic LOW. If the external output capacitor V_{OUT} is shorted to GND, the internal Schottky diode can be damaged, a condition which should be avoided.

LED Brightness Control

The control inputs are A1 and B1 for CH1 and A2 and B2 for CH2. B1 and B2 are digital inputs that require LOW (GND) and HIGH V_{IN} control signals. In analog mode, A1 and A2 are connected to an external stable voltage source via an external resistor, and B1 and B2 inputs are connected to ground. The current flowing through the resistor is scaled by a factor of approximately 1000.

LED dimming can be controlled with static or dynamic inputs from CH1 and CH2. CH1 and CH2 outputs are driven directly by A1, B1 and A2, B2 inputs, respectively. Either channel can be configured as analog or digital. Inputs A1 and A2 are analog inputs that can be connected to an external regulated voltage source, which can be calculated by:

$$V_{EXT} = \frac{I_{LED} \cdot R_{EXT}}{\text{CurrentMultiplicationRatio}} + 1.2V \quad \text{EQ 1}$$

where current multiplication ratio is according to the Electrical Specifications table.

Inputs B1 and B2 are digital inputs and can only be set by external logic of “0” (LOW) or “1” (HIGH).

Digital Static Control

The FAN5608's digital decoder allows selection of the following modes of operation: OFF, 5mA, 10mA, and 20mA per channel.

A	0	1	0	1
B	0	0	1	1
I _{LED}	OFF	5mA	10mA	20mA

Analog Static Control

In Analog Mode, B1 and B2 inputs should be connected to GND or "0" logic. A1 and A2 control the LED current through an external resistor (R), as shown in Figure 4, or an external voltage (V_{EXT}) input.

The I_{LED} value can be calculated using the formula or the graph below:

$$I_{LED} = \frac{V_{EXT} - 1.2V}{R} \cdot (CurrentMultiplicationRatio) \quad EQ 2$$

where $1.2V < V_{EXT} \leq R(k\Omega) \times 0.020(mA) + 1.2V$ and the current multiplication ratio is according to the Electrical Specifications table. The R value should be in the (10kΩ to 50kΩ) range.

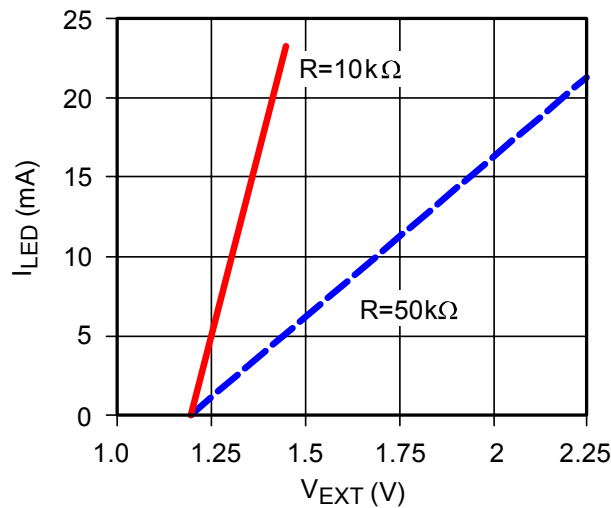

Figure 7. Analog Control

PWM Control in Digital Dynamic Mode

In Digital Dynamic Mode, if inputs A1 and/or A2 are externally driven by an open-drain output, the pull-up resistance should be less than 10kΩ to ensure less than 0.7V dropout; V_A > (V_{IN} - 0.7V), as required for HIGH logic level.

The logic level HIGH (V_H) and logic level LOW (V_L) of the PWM signal should be:

$$(V_{IN} - 0.7V) < V_H < V_{IN} \quad EQ 3$$

and

$$0 < V_L < 0.6V. \quad EQ 4$$

The frequency of the PWM signal should be within the 50Hz to 1kHz range, by default, or 30kHz at any input if the other input is kept HIGH.

PWM Control in Analog Dynamic Mode

In Analog Dynamic Mode, the logic level HIGH (V_H) and logic level LOW (V_L) of the PWM signal should be:

$$V_H = V_{EXT} \text{ and } 0 < V_L < 0.6V. \quad EQ 5$$

The frequency of the PWM signal should be in the range from 50Hz to 1kHz. The V_{EXT} amplitude sets the maximum LED current, while the duty cycle of the PWM signal sets the average current between 0mA and I_{LED} maximum.

Open-Circuit Protection

The FAN5608 has an internal over-voltage protection mechanism that prevents damage to the IC in a no-load condition. If CH1 and/or CH2 LEDs are enabled in an open-circuit condition, FAN5608 automatically sets the duty cycle to 25%. The output voltage can reach as high as 50V at maximum V_{IN} (5.5V). Depending on the capacitor's rating, the output capacitor may be at risk in this condition.

Shutdown Mode

Each channel can be independently disabled by applying LOW logic level voltage to the appropriate A and B inputs. When both channels are disabled, the FAN5608 enters shutdown mode and the supply current is reduced to less than 1μA.

PWM Control

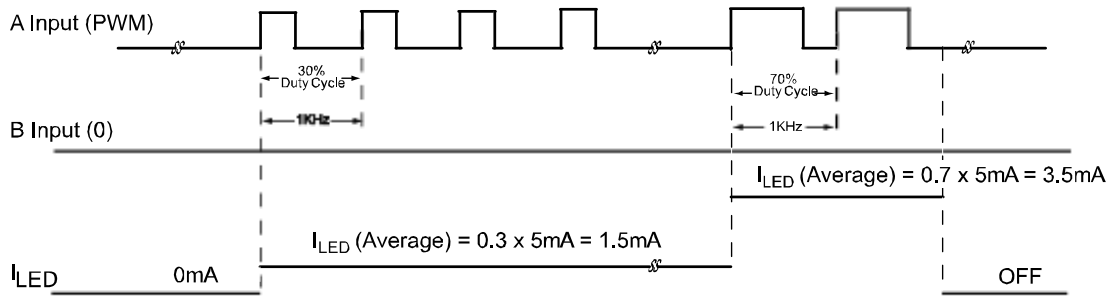

Figure 8. A is PWM controlled; B is LOW; $I_{LED} \text{ (average)} - s \times 5\text{mA}$, where s is the duty cycle⁽⁵⁾

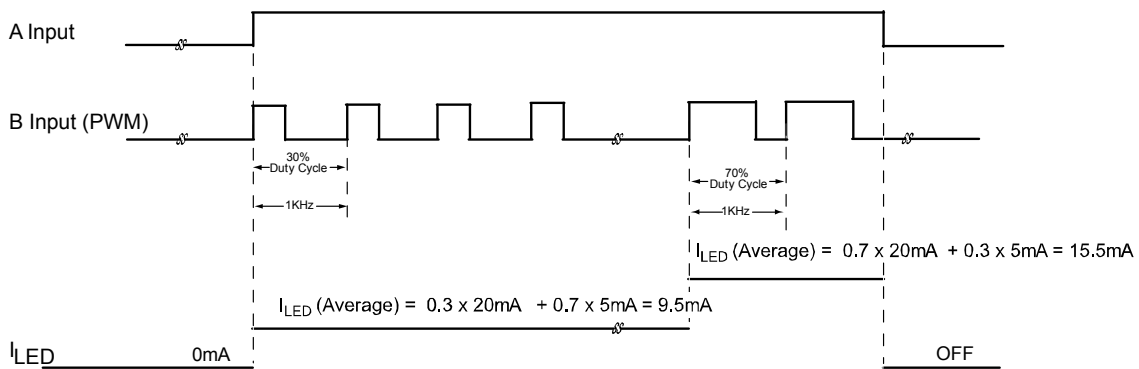

Figure 9. A is HIGH and B is PWM controlled; $I_{LED} \text{ (average)} - s \times 15\text{mA} + 5\text{mA}$, where s is the duty cycle⁽⁶⁾

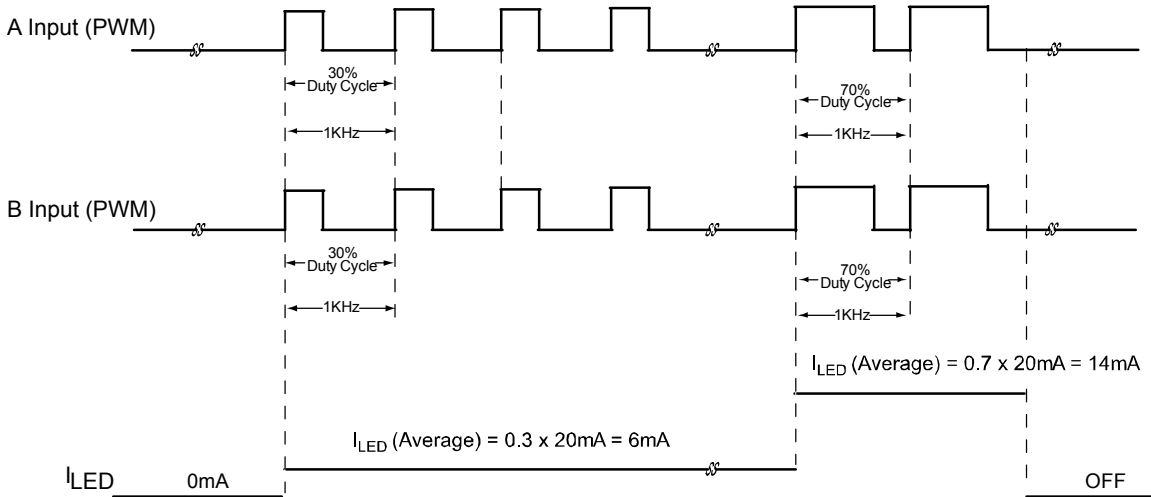

Figure 10. A and B are PWM controlled; $I_{LED} \text{ (average)} - s \times 20\text{mA}$, where s is the duty cycle⁽⁷⁾

Notes:

5. Proportionally select the duty cycle to achieve a typical LED current from 1mA to 4mA.
6. Maximum PWM frequency can be 30KHz.
7. Proportionally select the duty cycle to achieve a typical LED current from 1mA to 19mA.

Typical Characteristics

$T_A=25^{\circ}\text{C}$, $V_{\text{BAT}} = 3.6\text{V}$, unless otherwise specified.

Efficiency vs LED Current

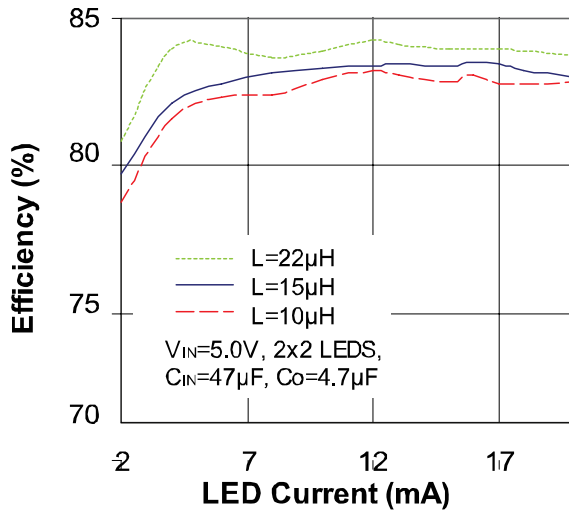

Figure 11. Peak power efficiency

LED Current vs Duty Cycle

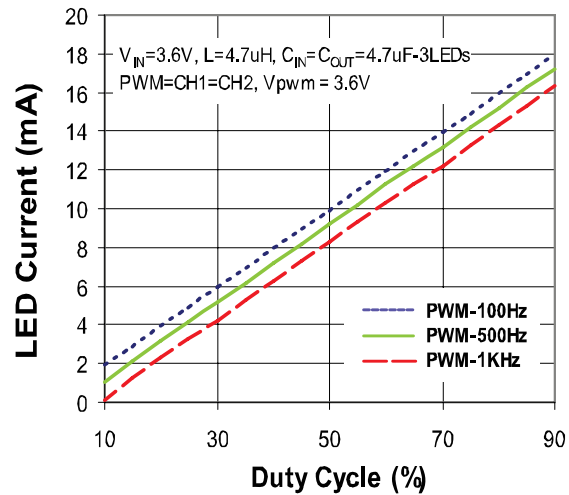

Figure 12. PWM Dimming

Startup Response

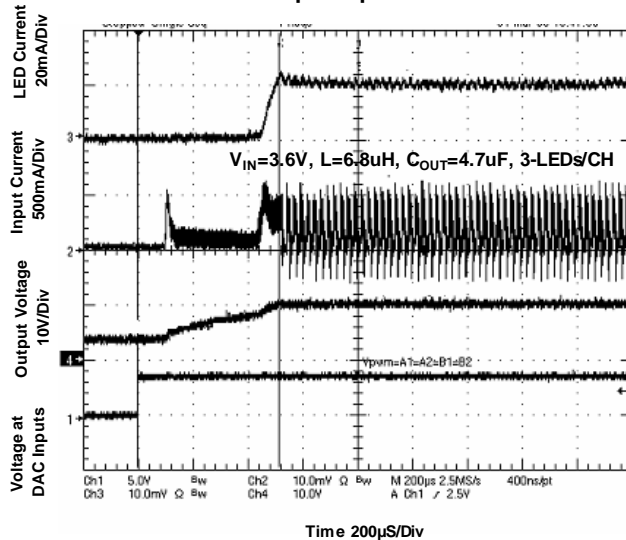

Figure 13. Startup Response

Design and Component Selection Guidelines

Inductor Selection

The inductor is one of the main components required by the boost converter to store energy. The amount of energy stored in the inductor and transferred to the load is controlled by the regulator, using pulse-frequency modulation (PFM) and pulse-skipping techniques. In most cases, the FAN5608 operates in discontinuous conduction mode, resulting in higher inductor current ripple.

To ensure proper operation of the current regulator over the entire range of conditions, select the inductor based

on the maximum output power (P_{OUT}) and the minimum input voltage (V_{IN}):

$$L \leq \frac{(V_{\text{IN}})^2 \times T}{P_{\text{OUT}}} \quad \text{EQ 6}$$

where units of L , V_{IN} , and P_{OUT} are in μH , Volt, and Watt, respectively and $T = 0.4\mu\text{s}$ is a factor depending upon the FAN5608 internal architecture. The above relationship is applicable up to $P_{\text{OUT}} = 0.8\text{W}$ and $L \geq 2.2\mu\text{H}$. At lower inductor values, the efficiency

decreases due to the resistive loss in the switching power FET. Using $L = 3.3\mu\text{H}$ and increasing the load to 12 LED x 20mA ($P_{\text{OUT}} = 800\text{mW}$) requires $V_{\text{IN}} > 3.5\text{V}$ to maintain a constant 20mA current through LEDs. An inductance $L = 4.7\mu\text{H}$ ensures proper operation for 2 x 4 white LEDs with regulated 20mA current if $V_{\text{IN}} > 2.7\text{V}$.

For any lighter load or higher V_{IN} , the inductance may be increased to improve the system efficiency. Application examples are given in Figures 16 - 25.

The peak current in the inductor depends on the maximum battery voltage and the inductance, according to the equation:

$$I_{pk} = \frac{1.4\mu\text{S} \times V_{\text{INmax}}}{L} \quad \text{EQ 7}$$

which gives the maximum rated current for the inductor. For $L = 4.7\mu\text{H}$ and $V_{\text{IN}} = 4.2\text{V}$, the inductor saturation current should be at least 1A.

Capacitors Selection

Low ESR capacitors should be used to minimize the input and output ripple voltage. Use of a $C_{\text{IN}} > 4.7\mu\text{F}/6.3\text{V}$ and $C_{\text{OUT}} = 4.7\mu\text{F}/25\text{V}$ type X5R/X7R multi-layer ceramic capacitor is recommended.

A larger value input capacitor placed as close as possible to FAN5608 may be needed to reduce the input voltage ripple in noise-sensitive applications. An additional LC filter between the battery and the FAN5608 input can help reduce the battery ripple to the level required by a particular application.

Driving Higher Current LEDs

To increase the LED current range to 50mA, the CH1 and CH2 outputs may be connected, as shown below:

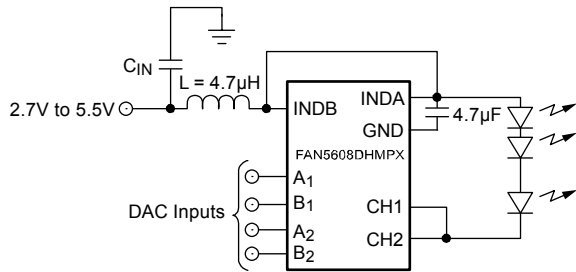

Figure 14. Digital Brightness Control

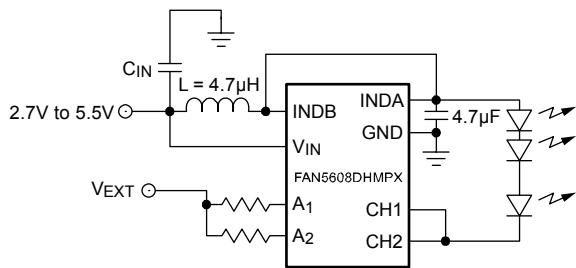

Figure 15. Analog Brightness Control

The current feeding the string of LEDs is the sum of the currents programmed for each channel in digital or analog mode. Using all four inputs in digital mode, the LED current can be programmed within the 0 to 40mA range, according to the following table:

Input A1	Input B1	Input A2	Input B2	I_{LED} (mA)
0	0	0	0	0
1	0	0	0	5
0	0	1	0	5
0	1	0	0	10
0	0	0	1	10
1	0	1	0	10
1	0	0	1	15
0	1	1	0	15
0	1	0	1	20
1	1	0	0	20
0	0	1	1	20
1	1	1	0	25
1	0	1	1	25
1	1	0	1	30
0	1	1	1	30
1	1	1	1	40

Driving Two Independent Strings of LEDs

For best efficiency, the two strings of LEDs driven by the FAN5608 should have close forward voltages. This recommendation is met when the same number and type of LEDs are serially connected in each channel. If the application requires the two channels be significantly unbalanced, an external resistor may be added in series with the shorter string of LEDs to reduce the voltage difference between the two channels and enhance performance. The maximum differential LEDs connected in series to CH1 and CH2 is not recommended to exceed three LEDs.

Specific Layout Recommendations

The FAN5608 is available in a dual Die Attach Pad (DAP) package. One DAP is connected to GND and another to V_{OUT} , making it unnecessary to provide any external connection to the DAPs. Since the internal power dissipation is low, the 4x4mm MLP package is capable of dissipating maximum power without requiring an extra copper field on the printed circuit board. When viewing the bottom of the dual-DAP device package, two electrically isolated exposed metal islands are visible. The two IND pins should be connected externally. Depending on the application noise sensitivity, an external filter may be required between the battery and the IC input.

FAN5608 Efficiency Curves

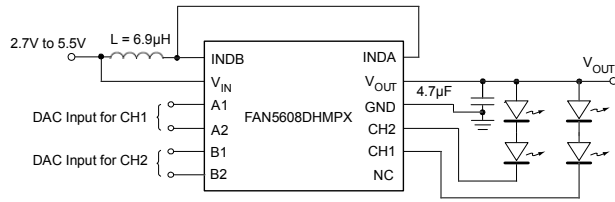

Figure 16. FAN5608 with four LEDs

Efficiency, LED Current vs Input Voltage
Four LEDs

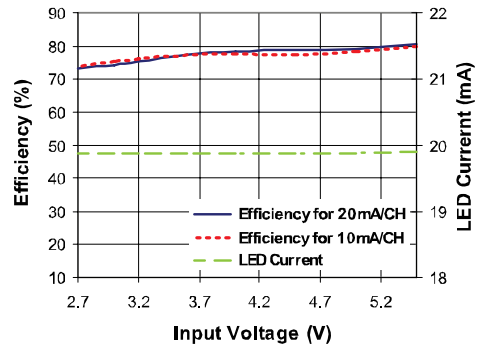

Figure 17. FAN5608 efficiency with four LEDs

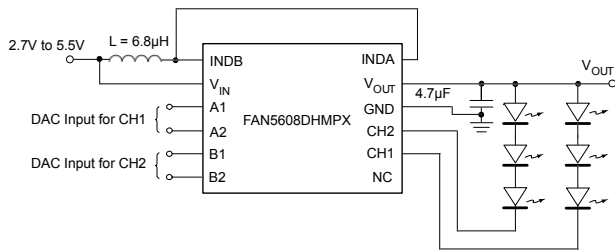

Figure 18. FAN5608 with six LEDs

Efficiency, LED Current vs Input Voltage
Six LEDs

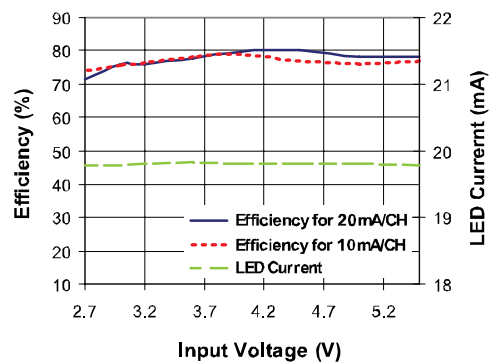

Figure 19. FAN5608 efficiency with six LEDs

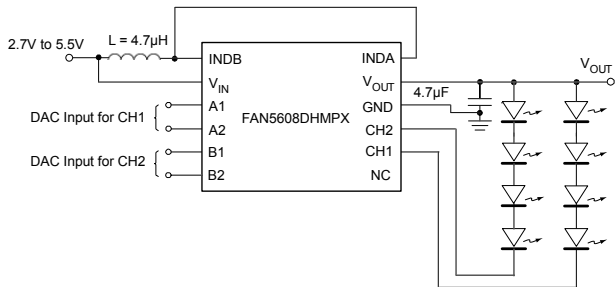

Figure 20. FAN5608 with eight LEDs

Efficiency, LED Current vs Input Voltage
Eight LEDs

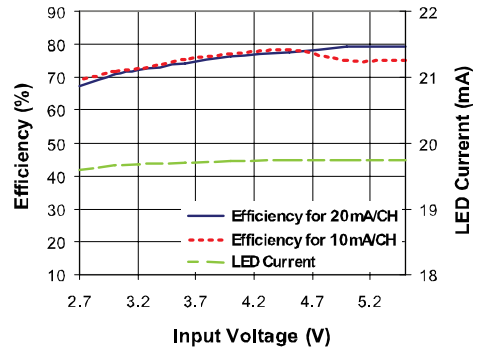

Figure 21. FAN5608 efficiency with eight LEDs

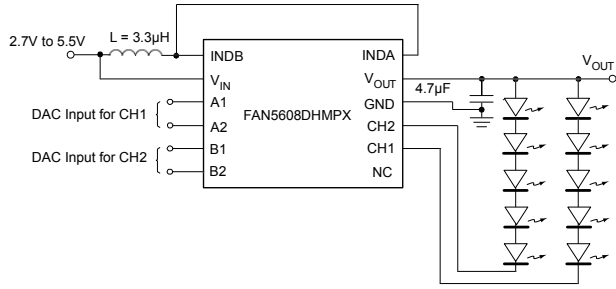

Figure 22. FAN5608 with ten LEDs

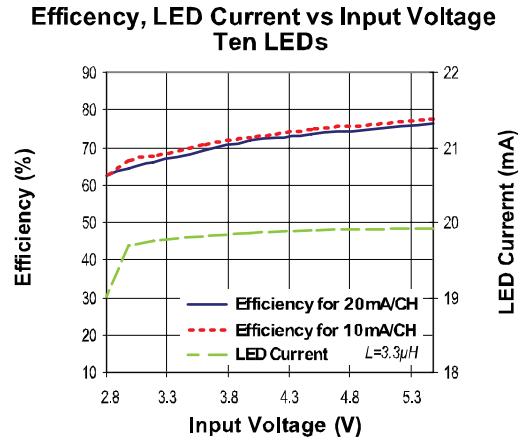

Figure 23. FAN5608 efficiency with ten LEDs

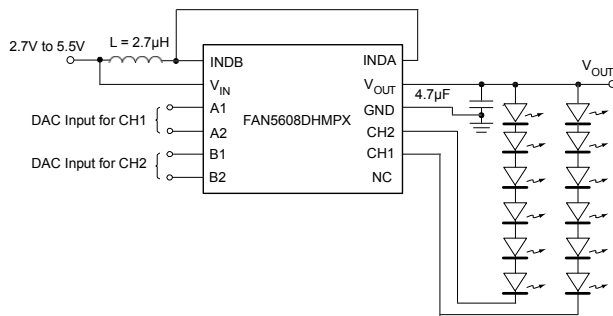

Figure 24. FAN5608 with twelve LEDs

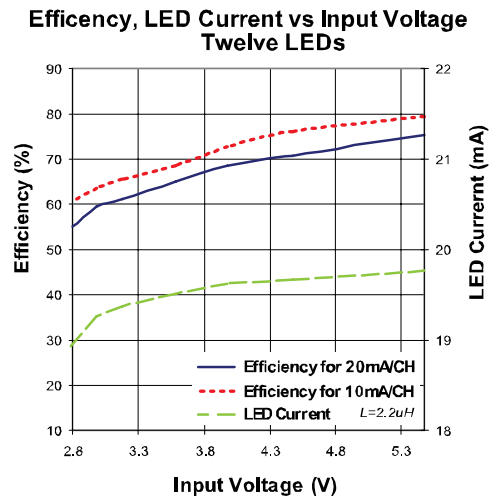
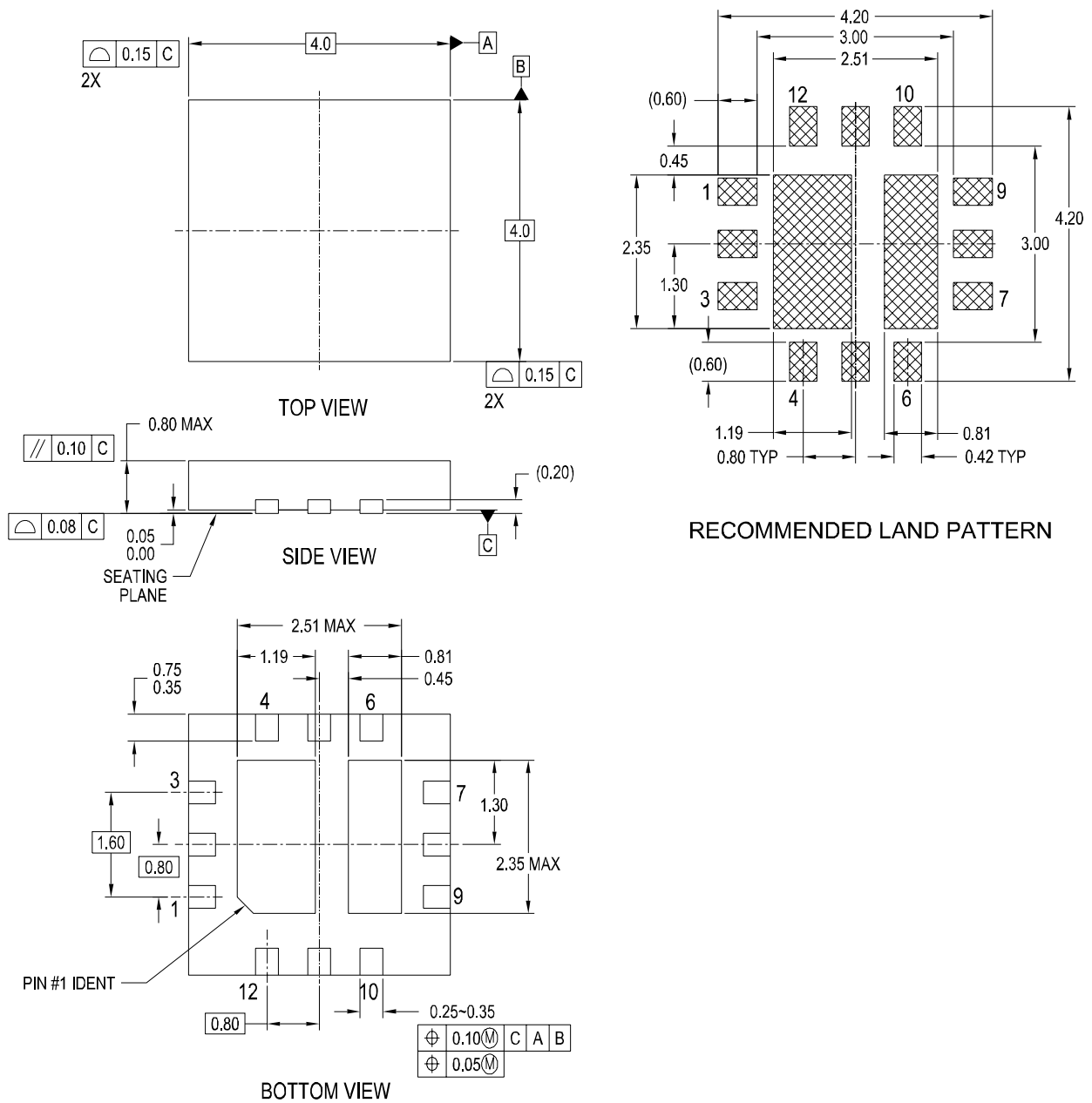

Figure 25. FAN5608 efficiency with twelve LEDs

Dimensional Outline Drawings

Dimensions are in millimeters unless otherwise noted.



NOTES:

- A. CONFORMS TO JEDEC REGISTRATION MO-220, VARIATION WGGB, DATED 08/2002
- B. DIMENSIONS ARE IN MILLIMETERS.
- C. DIMENSIONS AND TOLERANCES PER ASME Y14.5M, 1994

MLP12BrevA

Figure 26. 4x4mm 12-Lead MLP

TRADEMARKS

The following are registered and unregistered trademarks Fairchild Semiconductor owns or is authorized to use and is not intended to be an exhaustive list of all such trademarks.

ACE ^x ™	GlobalOptoisolator™	OCXPro™	μSerDes™	TinyBuck™
ActiveArray™	GTO™	OPTOLOGIC®	SILENT SWITCHER®	TinyLogic®
Bottomless™	HiSeC™	OPTOPLANAR™	SMART START™	TINYOPTO™
Build it Now™	I ² C™	PACMAN™	SPM™	TinyPower™
CoolFET™	i-Lo™	POP™	Stealth™	TinyPWM™
CROSSVOLT™	ImpliedDisconnect™	Power247™	SuperFET™	TruTranslation™
DOME™	IntelliMAX™	PowerEdge™	SuperSOT™-3	UHC™
EcoSPARK™	ISOPLANAR™	PowerSaver™	SuperSOT™-6	UltraFET®
E ² CMOS™	LittleFET™	PowerTrench®	SuperSOT™-8	UniFET™
EnSigna™	MICROCOUPLER™	QFET®	SyncFET™	VCX™
FACT™	MicroFET™	QS™	TCM™	Wire™
FACT Quiet Series™	MicroPak™	QT Optoelectronics™	TinyBoost™	
FAST®	MICROWIRE™	Quiet Series™		
FASTr™	MSX™	RapidConfigure™	Across the board. Around the world.™	
FPS™	MSXPro™	RapidConnect™	Programmable Active Droop™	
FRFET™	OCX™	ScalarPump™	The Power Franchise®	

DISCLAIMER

FAIRCHILD SEMICONDUCTOR RESERVES THE RIGHT TO MAKE CHANGES WITHOUT FURTHER NOTICE TO ANY PRODUCTS HEREIN TO IMPROVE RELIABILITY, FUNCTION OR DESIGN. FAIRCHILD DOES NOT ASSUME ANY LIABILITY ARISING OUT OF THE APPLICATION OR USE OF ANY PRODUCT OR CIRCUIT DESCRIBED HEREIN; NEITHER DOES IT CONVEY ANY LICENSE UNDER ITS PATENT RIGHTS, NOR THE RIGHTS OF OTHERS. THESE SPECIFICATIONS DO NOT EXPAND THE TERMS OF FAIRCHILD'S WORLDWIDE TERMS AND CONDITIONS, SPECIFICALLY THE WARRANTY THEREIN, WHICH COVERS THESE PRODUCTS.

LIFE SUPPORT POLICY

FAIRCHILD'S PRODUCTS ARE NOT AUTHORIZED FOR USE AS CRITICAL COMPONENTS IN LIFE SUPPORT DEVICES OR SYSTEMS WITHOUT THE EXPRESS WRITTEN APPROVAL OF FAIRCHILD SEMICONDUCTOR CORPORATION.

As used herein:

- Life support devices or systems are devices or systems which, (a) are intended for surgical implant into the body or (b) support or sustain life, and (c) whose failure to perform when properly used in accordance with instructions for use provided in the labeling, can be reasonably expected to result in a significant injury of the user.
- A critical component in any component of a life support device, or system whose failure to perform can be reasonably expected to cause the failure of the life support device or system, or to affect its safety or effectiveness.

PRODUCT STATUS DEFINITIONS

Definition of Terms

Datasheet Identification	Product Status	Definition
Advance Information	Formative or In Design	This datasheet contains the design specifications for product development. Specifications may change in any manner without notice.
Preliminary	First Production	This datasheet contains preliminary data; supplementary data will be published at a later date. Fairchild Semiconductor reserves the right to make changes at any time without notice to improve design.
No Identification Needed	Full Production	This datasheet contains final specifications. Fairchild Semiconductor reserves the right to make changes at any time without notice to improve design.
Obsolete	Not In Production	This datasheet contains specifications on a product that has been discontinued by Fairchild Semiconductor. The datasheet is printed for reference information only.

Rev. I20