

74VHC08 • 74VHCT08 Quad 2-Input AND Gate

General Description

The VHC/VHCT08 is an advanced high speed CMOS 2 Input AND Gate fabricated with silicon gate CMOS technology. It achieves the high-speed operation similar to equivalent Bipolar Schottky TTL while maintaining the CMOS low power dissipation.

The internal circuit is composed of 4 stages including buffer output, which provide high noise immunity and stable output. An input protection circuit insures that 0V to 7V can be applied to the input pins without regard to the supply voltage. This device can be used to interface 5V to 3V systems and two supply systems such as battery backup. This circuit prevents device destruction due to mismatched supply and input voltages.

Features

- Low power dissipation:
 $I_{CC} = 2 \mu A$ (Max) @ $T_A = 25^\circ C$
- High Speed:
 $t_{pd} = 4.3$ ns (typ) at $T_A = 25^\circ C$
- High noise immunity:
VHC $V_{NIH} = V_{NIL} = 28\% V_{CC}$ (min)
VHCT $V_{IH} = 2.0V, V_{IL} = 0.8V$
- Power down protection:
VHC inputs only
VHCT inputs and outputs
- Low noise:
 $V_{OLP} = 0.8V$ (max)
- Pin and function compatible with 74HC/HCT08

Note: Add external pull up resistor to VHCT outputs to drive CMOS inputs.

Ordering Code:

Commercial	Package Number	Package Description
74VHC08M	M14A	14-Lead Molded JEDEC SOIC
74VHC08SJ	M14D	14-Lead Molded EIAJ SOIC
74VHC08MTC	MTC14	14-Lead Molded JEDEC Type 1 TSSOP
74VHC08N	N14A	14-Lead Molded DIP
74VHCT08M	M14A	14-Lead Molded JEDEC SOIC
74VHCT08SJ	M14D	14-Lead Molded EIAJ SOIC
74VHCT08MTC	MTC14	14-Lead Molded JEDEC Type 1 TSSOP
74VHCT08N	N14A	14-Lead Molded DIP

Surface mount packages are also available on Tape and Reel. Specify by appending the suffix letter "X" to the ordering code.

Logic Symbol

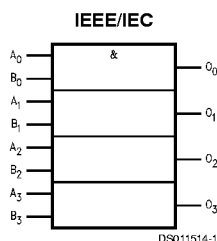

Connection Diagram

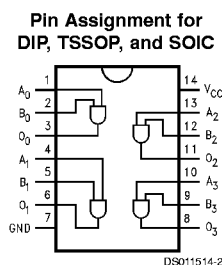

Pin Descriptions

Pin Names	Description
A_n, B_n	Inputs
O_n	Outputs

Truth Table

A	B	O
L	L	L
L	H	L
H	L	L
H	H	H

Absolute Maximum Ratings (Note 1)

Supply Voltage (V_{CC})	-0.5V to +7.0V
DC Input Voltage (V_{IN})	-0.5V to +7.0V
DC Output Voltage (V_{OUT})	
VHC	-0.5V to $V_{CC} + 0.5V$
VHCT (Note 2)	-0.5V to 7.0V
Input Diode Current (I_{IK})	-20 mA
Output Diode Current (I_{OK})	
VHC	±20 mA
VHCT	-20 mA
DC Output Current (I_{OUT})	±25 mA
DC V_{CC} /GND Current (I_{CC})	±50 mA
Storage Temperature (T_{STG})	-65°C to +150°C
Lead Temperature (T_L)	
(Soldering, 10 seconds)	260°C

Recommended Operating Conditions (Note 3)

Supply Voltage (V_{CC})	
VHC	2.0V to +5.5V
VHCT	4.5V to 5.5V
Input Voltage (V_{IN})	0V to +5.5V
Output Voltage (V_{OUT})	0V to V_{CC}
Operating Temperature (T_{OPR})	-40°C to +85°C
Input Rise and Fall Time (t_r , t_f)	
$V_{CC} = 3.3V \pm 0.3V$ (VHC only)	0 ns/V ~ 100 ns/V
$V_{CC} = 5.0V \pm 0.5V$	0 ns/V ~ 20 ns/V

Note 1: Absolute Maximum Ratings are values beyond which the device may be damaged or have its useful life impaired. The databook specifications should be met, without exception, to ensure that the system design is reliable over its power supply, temperature, and output/input loading variables. Fairchild does not recommend operation outside databook specifications.

Note 2: $V_{OUT} > V_{CC}$ only if output is in H state.

Note 3: Unused inputs must be held HIGH or LOW. They may not float.

DC Electrical Characteristics for VHC

Symbol	Parameter	V_{CC} (V)	$T_A = 25^\circ\text{C}$			$T_A = -40^\circ\text{C}$ to $+85^\circ\text{C}$		Units	Conditions	
			Min	Typ	Max	Min	Max			
V_{IH}	High Level Input Voltage	2.0 3.0–5.5	1.50 0.7 V_{CC}			1.50 0.7 V_{CC}		V		
V_{IL}	Low Level Input Voltage	2.0 3.0–5.5			0.50 0.3 V_{CC}		0.50 0.3 V_{CC}	V		
V_{OH}	High Level Output Voltage	2.0	1.9	2.0		1.9		V	$V_{IN} = V_{IH}$ or V_{IL}	$I_{OH} = -50 \mu\text{A}$
		3.0	2.9	3.0		2.9				
		4.5	4.4	4.5		4.4		V	$I_{OH} = -4 \text{ mA}$ $I_{OH} = -8 \text{ mA}$	
		3.0	2.58			2.48				
4.5	3.94			3.80						
V_{OL}	Low Level Output Voltage	2.0		0.0	0.1		0.1	V	$V_{IN} = V_{IH}$ or V_{IL}	$I_{OL} = 50 \mu\text{A}$
		3.0		0.0	0.1		0.1			
		4.5		0.0	0.1		0.1	V	$I_{OL} = 4 \text{ mA}$ $I_{OL} = 8 \text{ mA}$	
		3.0			0.36		0.44			
4.5			0.36		0.44					
I_{IN}	Input Leakage Current	0–5.5			±0.1		±1.0	μA	$V_{IN} = 5.5V$ or GND	
I_{CC}	Quiescent Supply Current	5.5			2.0		20.0	μA	$V_{IN} = V_{CC}$ or GND	

Noise Characteristics for VHC

Symbol	Parameter	V_{CC} (V)	$T_A = 25^\circ\text{C}$		Units	Conditions
			Typ	Limits		
V_{OLP} (Note 4)	Quiet Output Maximum Dynamic V_{OL}	5.0	0.3	0.8	V	$C_L = 50 \text{ pF}$
V_{OLV} (Note 4)	Quiet Output Minimum Dynamic V_{OL}	5.0	-0.3	-0.8	V	$C_L = 50 \text{ pF}$
V_{IHD} (Note 4)	Minimum High Level Dynamic Input Voltage	5.0		3.5	V	$C_L = 50 \text{ pF}$
V_{ILD} (Note 4)	Maximum Low Level Dynamic Input Voltage	5.0		1.5	V	$C_L = 50 \text{ pF}$

Note 4: Parameter guaranteed by design.

DC Electrical Characteristics for VHCT

Symbol	Parameter	V _{CC} (V)	T _A = 25° C			T _A = -40° C to +85° C		Units	Conditions
			Min	Typ	Max	Min	Max		
V _{IH}	High Level Input Voltage	4.5 5.5	2.0 2.0			2.0 2.0		V	
V _{IL}	Low Level Input Voltage	4.5 5.5			0.8 0.8		0.8 0.8	V	
V _{OH}	High Level Output Voltage	4.5	3.15	3.65		3.15		V	V _{IN} = V _{IH} I _{OH} = -50 μA
		4.5	2.5			2.4		V	or V _{IL} I _{OH} = -8 mA
V _{OL}	Low Level Output Voltage	4.5		0.0	0.1		0.1	V	V _{IN} = V _{IH} I _{OL} = 50 μA
		4.5			0.36		0.44	V	or V _{IL} I _{OL} = 8 mA
I _{IN}	Input Leakage Current	0-5.5			±0.1		±1.0	μA	V _{IN} = 5.5V or GND
I _{CC}	Quiescent Supply Current	5.5			2.0		20.0	μA	V _{IN} = V _{CC} or GND
I _{CC(T)}	Maximum I _{CC} / Input	5.5			1.35		1.50	mA	V _{IN} = 3.4V Other Inputs = V _{CC} or GND
I _{OFF}	Output Leakage Current (Power Down State)	0.0			0.5		5.0	μA	V _{OUT} = 5.5V

Noise Characteristics for VHCT

Symbol	Parameter	V _{CC} (V)	T _A = 25° C		Units	Conditions
			Typ	Limit		
V _{OLP} (Note 5)	Quiet Output Maximum Dynamic V _{OL}		0.4	0.8	V	C _L = 50 pF
V _{OLV} (Note 5)	Quiet Output Minimum Dynamic V _{OL}		-0.4	-0.8	V	C _L = 50 pF
V _{IHD} (Note 5)	Minimum High Level Dynamic Input Voltage			2.0	V	C _L = 50 pF
V _{ILD} (Note 5)	Maximum Low Level Dynamic Input Voltage			0.8	V	C _L = 50 pF

Note 5: Parameter guaranteed by design.

AC Electrical Characteristics for VHCT

Symbol	Parameter	V _{CC} (V)	T _A = 25° C			T _A = -40° C to +85° C		Units	Conditions
			Min	Typ	Max	Min	Max		
t _{PHL}	Propagation Delay	3.3±0.3		6.2	8.8	1.0	10.5	ns	C _L = 15 pF
t _{PLH}				8.7	12.3	1.0	14.0		C _L = 50 pF
		5.0±0.5		4.3	5.9	1.0	7.0	ns	C _L = 15 pF
				5.8	7.9	1.0	9.0		C _L = 50 pF
C _{IN}	Input Capacitance			4	10		10	pF	V _{CC} = Open
C _{PD}	Power Dissipation Capacitance			18				pF	(Note 6)

Note 6: C_{PD} is defined as the value of the internal equivalent capacitance which is calculated from the operating current consumption without load. Average operating current can be obtained by the equation: I_{CC (opr.)} = C_{PD} * V_{CC} * f_{IN} + I_{CC/4} (per gate).

AC Electrical Characteristics for VHCT

Symbol	Parameter	V _{CC} (V)	T _A = 25 C			T _A = -40 C to +85 C		Units	Conditions
			Min	Typ	Max	Min	Max		
t _{PLH}	Propagation Delay	5.0	5.0	6.9	1.0	8.0	ns	C _L = 15 pF	
t _{PHL}		±0.5	5.5	7.9	1.0	9.0		C _L = 50 pF	
C _{IN}	Input Capacitance		4	10		10	pF	V _{CC} = Open	
C _{PD}	Power Dissipation Capacitance		18				pF	(Note 7)	

Note 7: C_{PD} is defined as the value of the internal equivalent capacitance, which is calculated from the operating current consumption without load. Average operating current can be obtained from the equation: I_{CC} (opr.) = C_{PD} * V_{CC} * f_{IN} + I_{CC}/4 (per gate)

Physical Dimensions inches (millimeters) unless otherwise noted

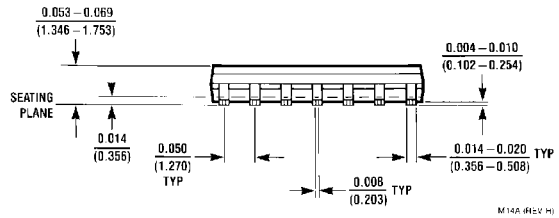
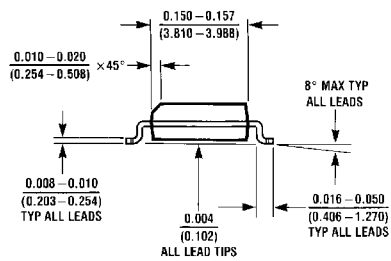
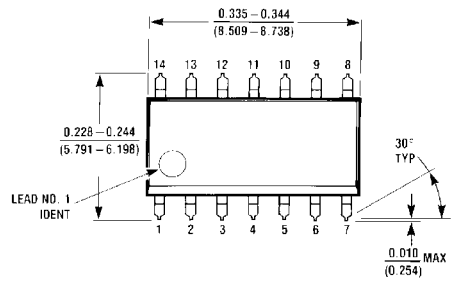

14-Lead Small Outline Integrated Circuit—JEDEC SOIC (M)
Package Number M14A

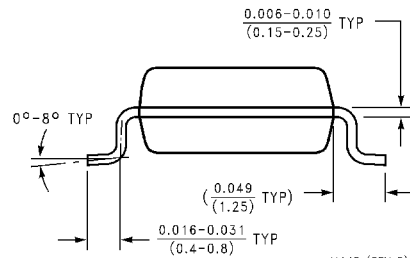
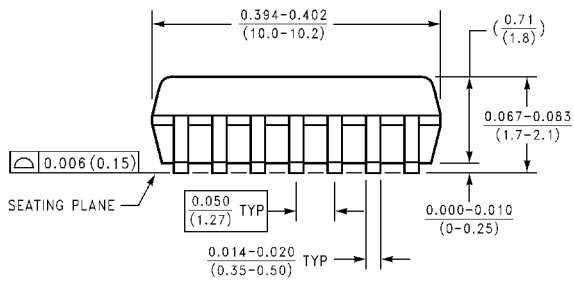
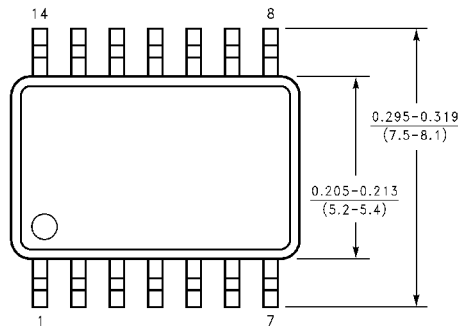

14-Lead Plastic EIAJ SOIC (SJ)
Package Number M14D

Physical Dimensions inches (millimeters) unless otherwise noted (Continued)

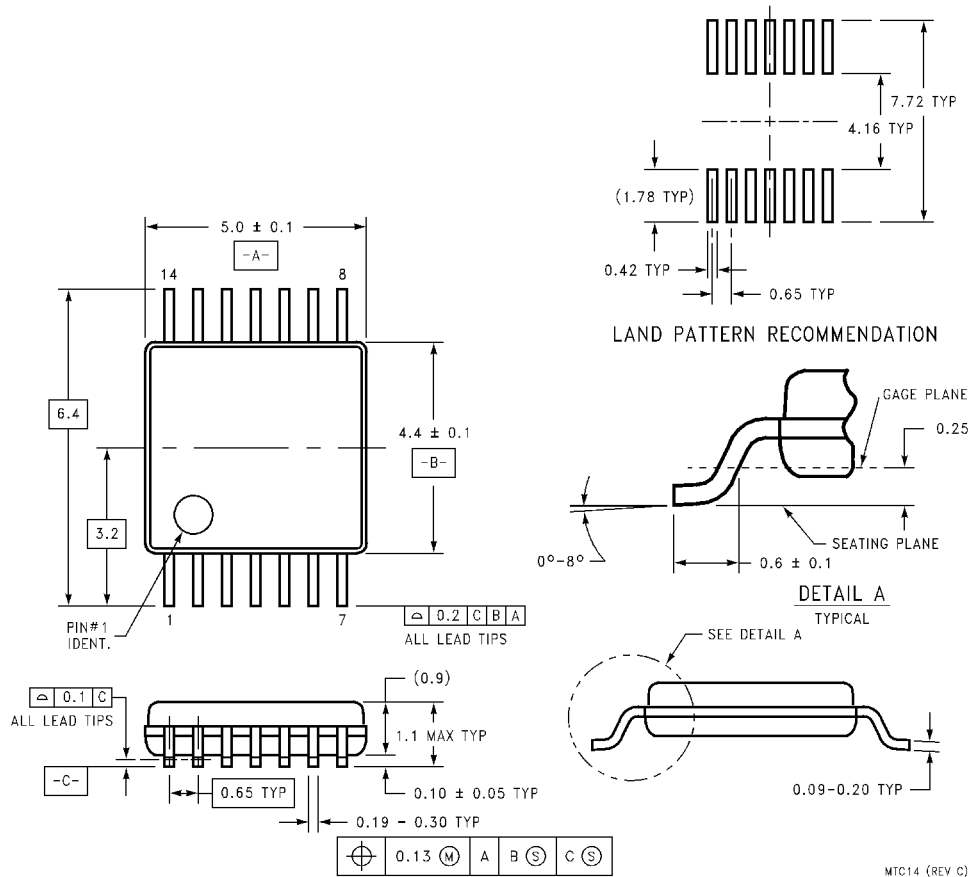

14-Lead Plastic JEDEC TSSOP Type I (MTC)
Package Number MTC14

MTC14 (REV C)

Physical Dimensions inches (millimeters) unless otherwise noted (Continued)

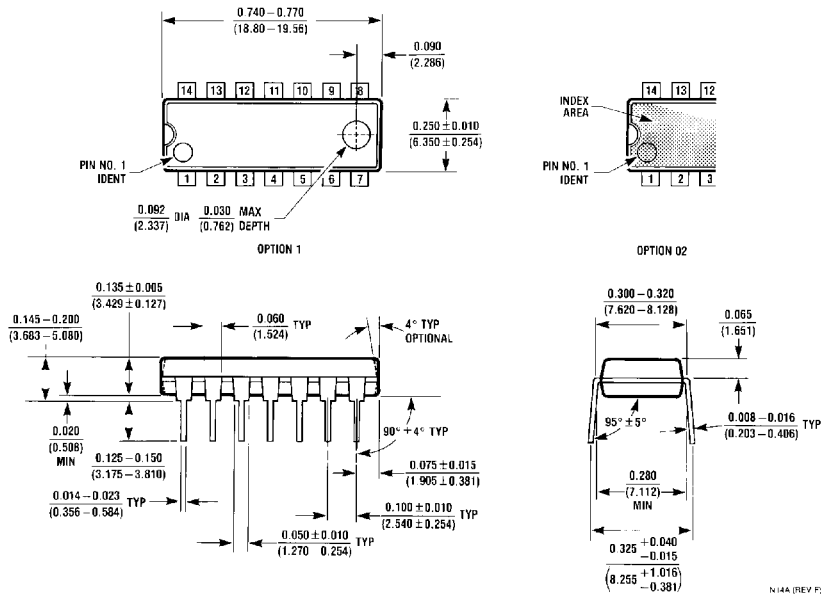

**14-Lead Molded Dual-In-Line Package (MDIP)
Package Number N14A**

LIFE SUPPORT POLICY

FAIRCHILD'S PRODUCTS ARE NOT AUTHORIZED FOR USE AS CRITICAL COMPONENTS IN LIFE SUPPORT DEVICES OR SYSTEMS WITHOUT THE EXPRESS WRITTEN APPROVAL OF THE PRESIDENT OF FAIRCHILD SEMICONDUCTOR CORPORATION. As used herein:

1. Life support devices or systems are devices or systems which, (a) are intended for surgical implant into the body, or (b) support or sustain life, and (c) whose failure to perform when properly used in accordance with instructions for use provided in the labeling, can be reasonably expected to result in a significant injury to the user.
2. A critical component in any component of a life support device or system whose failure to perform can be reasonably expected to cause the failure of the life support device or system, or to affect its safety or effectiveness.

Fairchild Semiconductor Corporation
Americas
Customer Response Center
Tel: 1-888-522-5372

Fairchild Semiconductor Europe
Fax: +49 (0) 1 80-530 85 86
Email: europe.support@nsc.com
Deutsch Tel: +49 (0) 8 141-35-0
English Tel: +44 (0) 1 793-85-68-56
Italy Tel: +39 (0) 2 57 5631

Fairchild Semiconductor Hong Kong Ltd.
13th Floor, Straight Block,
Ocean Centre, 5 Canton Rd.
Tsimshatsui, Kowloon
Hong Kong
Tel: +852 2737-7200
Fax: +852 2314-0061

National Semiconductor Japan Ltd.
Tel: 81-3-5620-6175
Fax: 81-3-5620-6179

www.fairchildsemi.com