



5V DC Single Channel Full-bridge Motor Driver

**CJDR9110 Motor Driver**

**1 Introduction**

CJDR9110 is a 5V DC brushed motor drive, which is internally integrated with an H bridge composed of four MOSFETs, and can be controlled through PWM interfaces (IN / IN) compatible with industry standard devices. CJDR9110 can allow continuous output current up to 1.3A and peak current up to 2.3A, and also has functions such as thermal shutdown and undervoltage locking. Therefore, CJDR9110 is very suitable for cameras, toys, consumer products and other low-voltage battery powered equipment.

**2 Available Package**

PART NUMBER	PACKAGE
CJDR9110	ESOP8

**Note:** For more detailed packaging information, see the part *Pin Configuration and Function* and the part *Mechanical Information*.

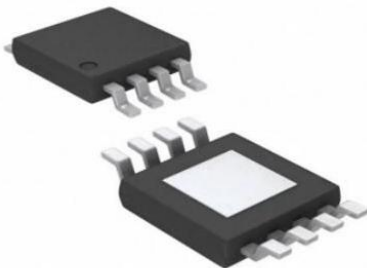

Figure 2-1. ESOP-8 Package

**3 Features**

- Independent H-bridge motor
- Operating input voltage: 1.2 ~ 6.0V
- 420mΩ conduction internal resistance (HS + LS)
- 1.3A output current drive capability
- PWM control with IN 1 / IN 2
- Internal integrated current regulation function
- Low power sleep mode
- Thermal shutdown protection
- Undervoltage locking

**4 Applications**

- Video Camera
- Digital Single Lens Reflective (DSLR) Lens
- Toys
- Robotics
- Shared Bicycle Lock
- Water Gas Meter Switch
- Medical Equipment
- Electric Toothbrush

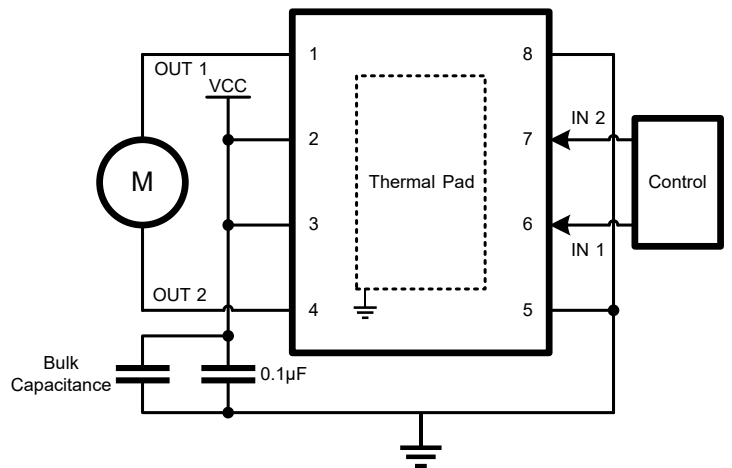

Figure 4-1. Typical Application Circuits

5 Pin Configuration and Function

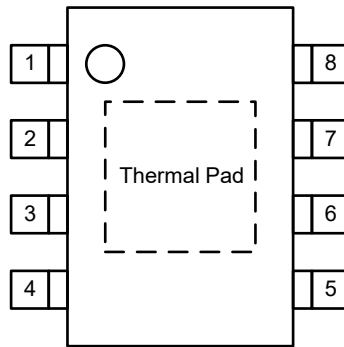

Figure 5-1. CJDR9110 Pin Map

PIN NAME	CJDR9110	I / O	DESCRIPTION
	ESOP8		
1	OUT 1	O	H-bridge output 1. Connect directly to the motor or other inductive load.
2 & 3	VCC	I	1.2V to 6.0V power supply. Connect a 0.1- $\mu$ F bypass capacitor to ground, as well as sufficient bulk capacitance, rated for the VCC voltage.
4	OUT 2	I	H-bridge output 2. Connect directly to the motor or other inductive load.
5 & 8	GND	-	Logic ground. Connect to system ground.
6	IN 1	O	Logic input 1. Controls the H-bridge output. Has internal pulldowns.
7	IN 2	O	Logic input 2. Controls the H-bridge output. Has internal pulldowns.
-	Thermal Pad	-	Thermal pad. Connect to system ground. For good thermal dissipation, use large ground planes on multiple layers, and multiple nearby vias connecting those planes.

## 6 Specifications

### 6.1 Absolute Maximum Ratings

( $T_A = 25^\circ\text{C}$ , unless otherwise specified)<sup>(1)</sup>

CHARACTERISTIC			SYMBOL	VALUE	UNIT
Power supply voltage <sup>(2)</sup>			$V_{CC}$	-0.3 ~ 7	V
Logic input pin voltage <sup>(2)</sup>			$V_{INx}$	-0.5 ~ 7	
Peak output current			$I_{PEAK}$	2.3	A
Maximum power dissipation	CJDR9110	ESOP8	$P_{D\ Max}$	Internally Limited <sup>(3)</sup>	W
Maximum junction temperature			$T_{J\ Max}$	150	$^\circ\text{C}$
Storage temperature			$T_{stg}$	-60 ~ 150	$^\circ\text{C}$
Soldering temperature & time			$T_{solder}$	260 $^\circ\text{C}$ , 10s	-

(1) Stresses beyond those listed under *Absolute Maximum Ratings* may cause permanent damage to the device. These are stress ratings only, which do not imply functional operation of the device at these or any other conditions beyond those indicated under *Recommended Operating Conditions*. Exposure to absolute-maximum rated conditions for extended periods may affect device reliability.

(2) All voltages are with respect to network ground terminal.

(3) Refer to *Thermal Information* for details.

### 6.2 Recommend Operating Conditions

PARAMETER <sup>(4)</sup>	SYMBOL	MIN.	NOM.	MAX.	UNIT
Power supply voltage	$V_{CC}$	1.2	-	6.0	V
Logic input pin voltage	$V_{INx}$	0	-	7.0	V
Output current (continuous) <sup>(5)</sup>	$I_{OUT}$	0	-	1.3	A
PWM frequency	$f_{PWM}$	0	-	250	kHz
Operating ambient temperature <sup>(6)</sup>	$T_A$	-40	-	100	$^\circ\text{C}$

(4) JSCJ recommends that users should not exceed the rated value in the *Recommended Operating Conditions* for the application conditions of the equipment, so as to ensure the stability of normal operation and reliability of long-term operation of the equipment. Operation beyond the recommended rated conditions does not mean that the product will fail. The consumers need to evaluate the risks that may be caused by the operation of the product beyond the recommended rated conditions.

(5) Power dissipation and thermal limits must be observed.

(6) It is necessary to ensure that the operating junction temperature of the equipment does not exceed the rated value of the recommended operating conditions when using the device for design.

## 6 Specifications

### 6.3 ESD Ratings

ESD RATINGS		SYMBOL	VALUE	UNIT
Electrostatic discharge <sup>(7)</sup>	Human body model	$V_{ESD-HBM}$	4000	V

(7) ESD testing is conducted in accordance with the relevant specifications formulated by the Joint Electronic Equipment Engineering Commission (JEDEC). The human body model (HBM) electrostatic discharge test is based on the JESD22-114D test standard, using a 100pF capacitor and discharging to each pin of the device through a resistance of 1.5kΩ.

### 6.4 Thermal Information

THERMAL METRIC <sup>(8)</sup>	SYMBOL	CJDR9110	UNIT
Junction-to-ambient thermal resistance	$R_{\theta JA}$	<b>ESOP8</b>	°C/W
		43.3	
Reference maximum power dissipation for continuous operation	$P_{D Ref}$	<b>ESOP8</b>	W
		2.31	

(8)  $T_A = 25^\circ\text{C}$ , all numbers are typical, and apply for packages soldered directly onto a PCB board in still air.

## 6 Specifications

### 6.5 Electrical Characteristics

CJDR9110 ( $V_{CC} = 5.0V$ ,  $T_A = 25^\circ C$ , unless otherwise specified)

CHARACTERISTIC	SYMBOL	TEST CONDITIONS	MIN.	TYP. <sup>(9)</sup>	MAX.	UNIT	
<b>Power Supply</b>							
Power supply voltage	$V_{CC}$	-	3.0	5.0	6.0	V	
Power supply current 1	$I_{VCC}$	$V_{CC} = 5V$ , without PWM	-	200	550	$\mu A$	
Power supply current 2	$I_{VCCQ}$	$V_{CC} = 5V$ , $I_{N1} = I_{N2} = 0V$ , power saving mode	-	0.01	1.0	$\mu A$	
<b>Output H-bridge Parameters</b>							
High + Low bridge conduction resistance	$R_{DS\ ON}$	$V_{CC} = 5V$ , $I_{OUT} = 500mA$	-	420	600	m $\Omega$	
Off leakage current	$I_{OFF}$	$V_{OUT} = 0V$	-200	-	200	nA	
<b>Logic Input Pin (IN 1, IN 2)</b>							
Input logic low voltage	$V_{IL}$	High level to low level	$V_{CC} = 3V$	0	-	0.75	V
			$V_{CC} = 5V$	0	-	1.0	
Input logic high voltage	$V_{IH}$	Low level to high level	$V_{CC} = 3V$	1.3	-	$V_{CC}$	V
			$V_{CC} = 5V$	2.1	-	$V_{CC}$	
Input logic hysteresis	$V_{HY}$	$V_{CC} = 3V$	-	0.4	-	V	
		$V_{CC} = 5V$	-	0.6	-		
Logic low input current	$I_{IL}$	$V_{INx} = 0V$	-5	-	5	$\mu A$	
Logic high input current	$I_{IH}$	$V_{INx} = 3.3V$	-	350	-	$\mu A$	
Pull down resistance	$R_{PD}$	-	-	10	-	k $\Omega$	
<b>Thermal Shutdown Protection</b>							
Thermal shutdown	$T_{SD}$	-	150	170	180	$^\circ C$	
Thermal shutdown hysteresis	$\Delta T_{SD}$	-	-	30	-	$^\circ C$	
<b>Undervoltage Locking</b>							
Undervoltage locking voltage	$V_{ULO}$	Supply rising	-	2.0	-	V	
Undervoltage locking hysteresis	$\Delta V_{ULO}$	Supply falling	-	200	-	mV	

**Note:**

(9) Typical numbers are at  $25^\circ C$  and represent the most likely norm.

## 6 Specifications

### 6.6 Time Series Parameters

CJDR9110 ( $V_{CC} = 5.0V$ ,  $T_A = 25^\circ C$ ,  $R_L = 20\Omega$ , unless otherwise specified)

CHARACTERISTIC	SYMBOL	TEST CONDITIONS	MIN.	TYP. <sup>(9)</sup>	MAX.	UNIT
Start-up time	T1	-	-	600	-	ns
Shutdown time	T2	-	-	180	220	ns
Input high to output high delay	T3	-	-	160	200	ns
Input low to output low delay	T4	-	-	10	100	ns
Output rising edge time	T5	-	-	35	188	ns
Output drop edge time	T6	-	-	10	188	ns

**Note:**

(9) Typical numbers are at 25°C and represent the most likely norm.

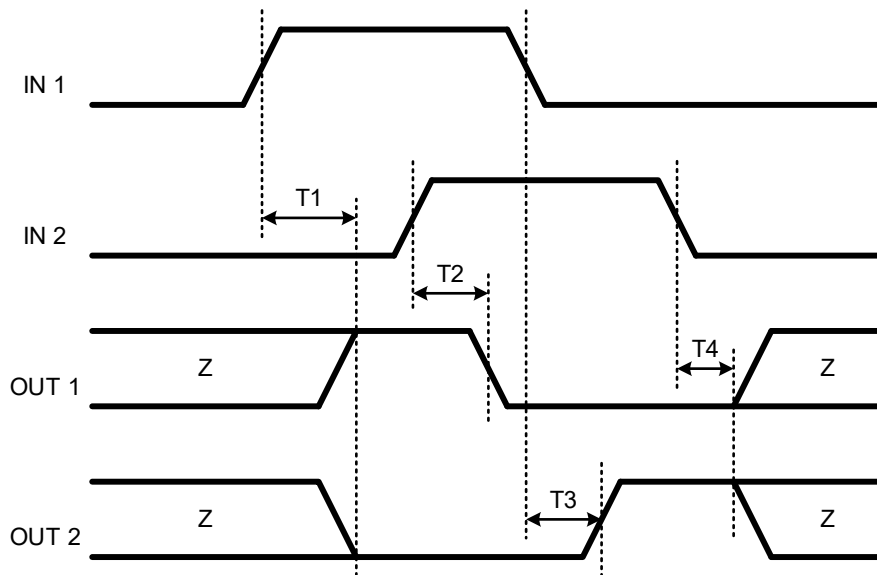

Figure 6-1. Input and Output Parameter Curve 1  
(T1, T2, T3, T4)

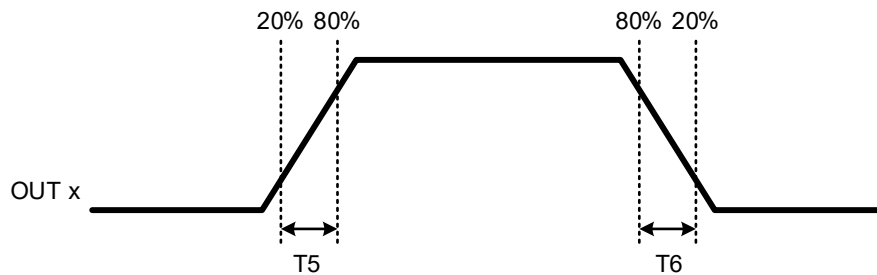

Figure 6-2. Input and Output Parameter Curve 2  
(T5, T6)

## 7 Detailed Description

### 7.1 Description

CJDR9110 is a single-channel full-bridge driver that provides up to 1.3A continuous output current and can operate at 1.2 ~ 6.0V power supply voltage. CJDR9110 has industry standard compatible PWM (IN / IN) input interface, and has thermal shutdown protection functions.

### 7.2 Function Block Diagram

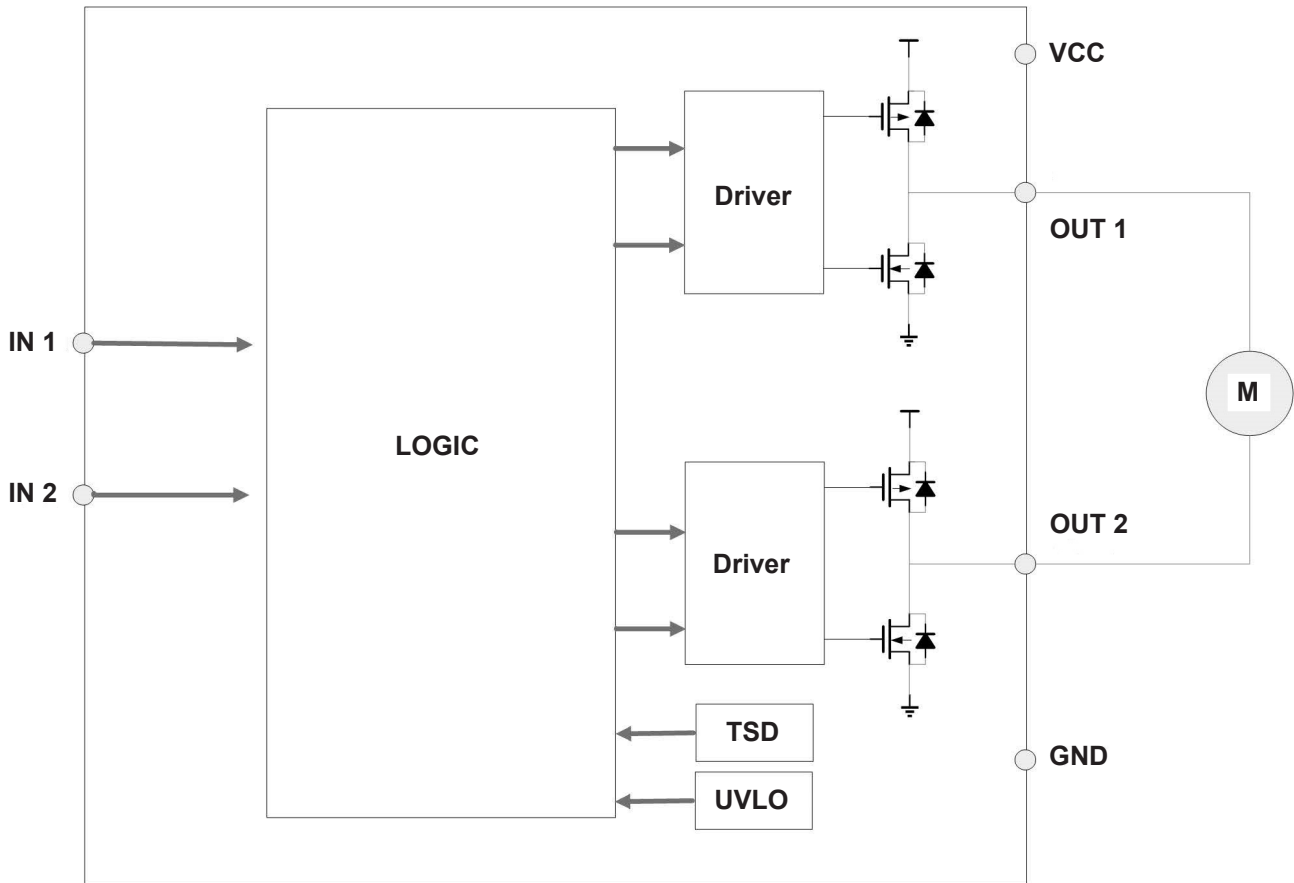

## 7 Detailed Description

### 7.3 Feature Description

#### PWM Control Mode

CJDR9110 is controlled by PWM input interface, also known as IN / IN input mode, the PWM interface (IN 1 / IN 2) controls the OUT x pins according to the logic table in Table 7-1.

**Table 7-1. PWM Control Mode with Automatic Sleep**

IN 1	IN 2	OUT 1	OUT 2	DESCRIPTION
0	0	Hi-Z	Hi-Z	Coast (H-bridge Hi-Z) / low-power automatic sleep mode
0	1	L	H	Reverse (OUT 2 → OUT 1)
1	0	H	L	Forward (OUT 1 → OUT 2)
1	1	L	L	Brake (low-side slow decay)

#### Output Driver

Since the  $V_{GS}$  of the driving power supply of the output driver tube is related to the power supply, the H-bridge output conduction resistance of the CJDR9110 decreases with the increase of the voltage, so the current capacity of the chip decreases at low voltage.

#### Sleep Mode

When IN 1 and IN 2 are low at the same time, the chip works normal.

When IN 1 = IN 2 = 0, the chip enters a low-power sleep mode, the internal circuit stops working, and the total current is less than 1 $\mu$ A.

#### Input Pin

IN 1 and IN 2 input pins have 100k $\Omega$  resistance pull-down, and the default is low level.

#### Over Temperature Protection

When the chip junction temperature exceeds 170 $^{\circ}$ C, the over temperature protection circuit is activated and all output tubes are turned off. When the temperature decreases by a hysteresis temperature of 30 $^{\circ}$ C to 140 $^{\circ}$ C, the output tube returns to work. However, because the over temperature protection is activated only when the chip junction temperature exceeds the set value, it does not guarantee that the product will be protected from damage with this circuit.

#### Undervoltage Locking

When the chip power supply voltage is lower than 2.0V (Typ.), the internal detection circuit will turn off the H-bridge output. If the voltage recovers, the output turns on again when it rises to 2.2V (Typ.).



## 7 Detailed Description

### 7.3 Feature Description (continued)

#### Operation Mode

CJDR9110 enters the sleep mode when IN 1 = IN 2 is low. In the sleep mode, all h bridges are turned off and output high resistance state. Most circuits of chip circuits are turned off and enter the power saving mode. When IN 1 and IN 2 are not low at the same time, they will automatically resume normal operation.

When the over temperature protection detects failure, it will also close the H-bridge.

**Table 7-2. Operation Mode**

IN 1	IN 2	OUT 1	OUT 2	DESCRIPTION
0	0	Hi-Z	Hi-Z	Sleep mode
0	1	L	H	Reverse (OUT 2 → OUT 1)
1	0	H	L	Forward (OUT 1 → OUT 2)
1	1	H	H	Brake (low-side slow decay)

## 8 Application and Implementation

### 8.1 Typical Application Circuit

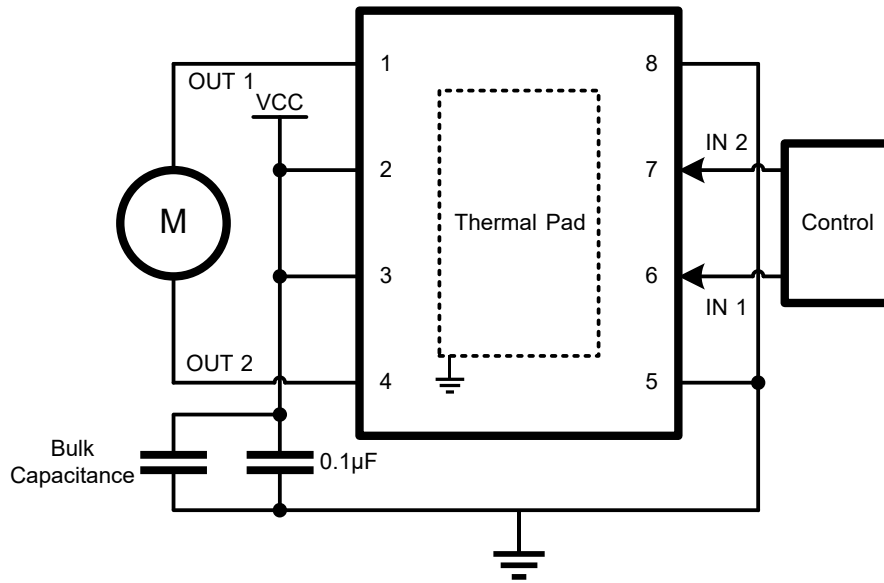

### 8.2 Power Supply Recommendations

Having appropriate local bulk capacitance is an important factor in motor drive system design. Having more bulk capacitance is generally beneficial, while the disadvantages are increased cost and physical size.

The amount of local capacitance needed depends on a variety of factors, including:

- The highest current required by the motor system;
- The capacitance of the power supply and ability to source current;
- The amount of parasitic inductance between the power supply and motor system;
- The acceptable voltage ripple; The type of motor used (brushed DC, brushless DC, stepper);
- The motor braking method.

The inductance between the power supply and motor drive system limits how the rate current can change from the power supply. If the local bulk capacitance is too small, the system responds to excessive current demands or dumps from the motor with a change in voltage. When adequate bulk capacitance is used, the motor voltage remains stable and high current can be quickly supplied.

The data sheet generally provides a recommended value, but system-level testing is required to determine the appropriate sized bulk capacitor.

The voltage rating for bulk capacitors should be higher than the operating voltage, to provide margin for cases when the motor transfers energy to the supply.

#### NOTE

The application information in this section is not part of the data sheet component specification, and JSCJ makes no commitment or statement to guarantee its accuracy or completeness. Customers are responsible for determining the rationality of corresponding components in their circuit design and making tests and verifications to ensure the normal realization of their circuit design.

9 Mechanical Information

ESOP8 Package Outline Dimensions

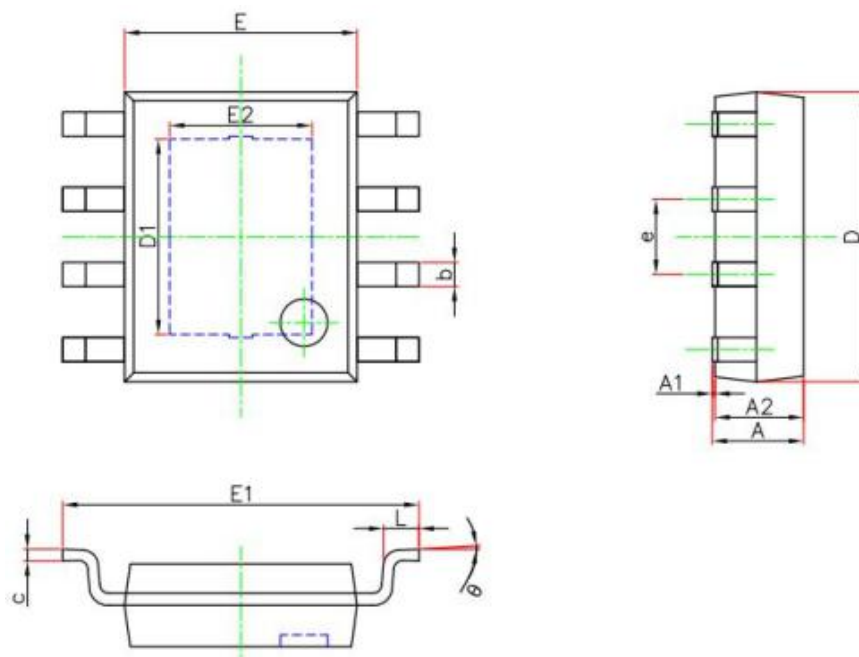

SYMBOL	DISMENSIONS IN MILLIMETERS			DISMENSIONS IN INCHES		
	MIN	NOM	MAX	MIN	NOM	MAX
A	1.300	-	1.700	0.051	-	0.067
A1	0.000	-	0.100	0.000	-	0.004
A2	1.350	-	1.550	0.053	-	0.061
b	0.330	-	0.510	0.013	-	0.020
c	0.170	-	0.250	0.007	-	0.010
D	4.700	-	5.100	0.185	-	0.201
D1	3.202	-	3.402	0.126	-	0.134
E	3.800	-	4.000	0.150	-	0.157
E1	5.800	-	6.200	0.228	-	0.244
E2	2.313	-	2.513	0.091	-	0.099
e	1.270 Bsc.			0.050 Bsc.		
L	0.400	-	1.270	0.016	-	0.050
θ	0°	-	8°	0°	-	8°

## 10 Notes and Revision History

### 10.1 Associated Product Family and Others

To view other products of the same type or IC products of other types, please click the official website of JSCJ -- <https://www.jscj-elec.com> for more details.

### 10.2 Notes

#### Electrostatic Discharge Caution



This IC may be damaged by ESD. Relevant personnel shall comply with correct installation and use specifications to avoid ESD damage to the IC. If appropriate measures are not taken to prevent ESD damage, the hazards caused by ESD include but are not limited to degradation of integrated circuit performance or complete damage of integrated circuit. For some precision integrated circuits, a very small parameter change may cause the whole device to be inconsistent with its published specifications.

### 10.3 Revision History

November, 2022: released CJDR9110 rev - 1.0.

# DISCLAIMER

## **IMPORTANT NOTICE, PLEASE READ CAREFULLY**

The information in this data sheet is intended to describe the operation and characteristics of our products. JSCJ has the right to make any modification, enhancement, improvement, correction or other changes to any content in this data sheet, including but not limited to specification parameters, circuit design and application information, without prior notice.

Any person who purchases or uses JSCJ products for design shall: 1. Select products suitable for circuit application and design; 2. Design, verify and test the rationality of circuit design; 3. Procedures to ensure that the design complies with relevant laws and regulations and the requirements of such laws and regulations. JSCJ makes no warranty or representation as to the accuracy or completeness of the information contained in this data sheet and assumes no responsibility for the application or use of any of the products described in this data sheet.

Without the written consent of JSCJ, this product shall not be used in occasions requiring high quality or high reliability, including but not limited to the following occasions: medical equipment, military facilities and aerospace. JSCJ shall not be responsible for casualties or property losses caused by abnormal use or application of this product.

Official Website: [www.jscj-elec.com](http://www.jscj-elec.com)

Copyright © JIANGSU CHANGJING ELECTRONICS TECHNOLOGY CO., LTD.