

注：本板为禁止运输、复制、翻印文件，以及用其内容进行交流

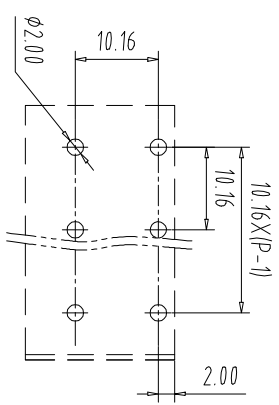
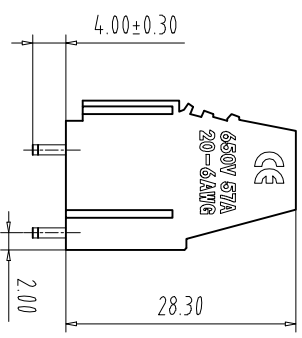
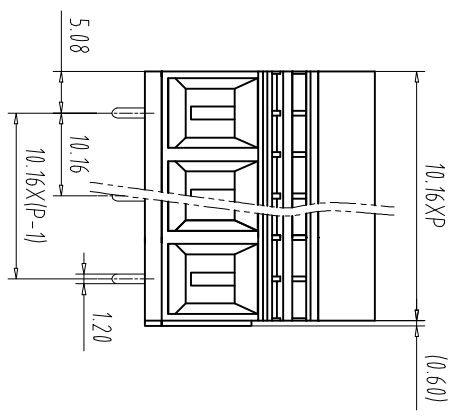
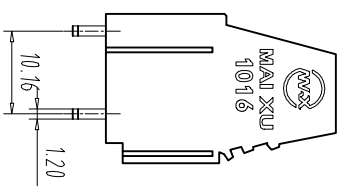
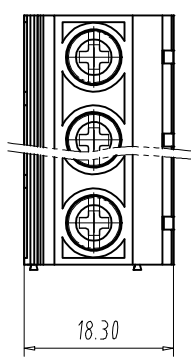

REV	ECN NO.	CONTENT	CHK	DATE

- NOTES1:  
 UL Standard  
 1.Rating voltage/current: 650V/57A  
 2.withstanding voltage: AC1600V/1min  
 3.Torque value: M4, 10.53Lb.in  
 4.Wire range: 20~6AWG  
 IEC Standard

1. Pollution Degree	3	2	2
Overvoltage Category	III	III	II
Rate Impulse Voltage(kV)	/	/	/
Rate Voltage(V)	/	630V	/
Rate Current(A)	/	57A	/

2. Torque value: M4, 1.2Nm  
 3.wire range: 10.00mm<sup>2</sup>

NOTES2:

- Housing: PA66(UL94V-0)
- Solder Pin: Copper alloy(Sn Plated)
- Cage: Steel(Zn Plated)
- Screw: Steel(M4, Zn Plated)

NOTES3:

- Pitch: 10.16mm Poles: 02-24P
- Stripping length: 10mm
- Operating temperature: -40℃~+105℃
- Rohs Compliance

How to order

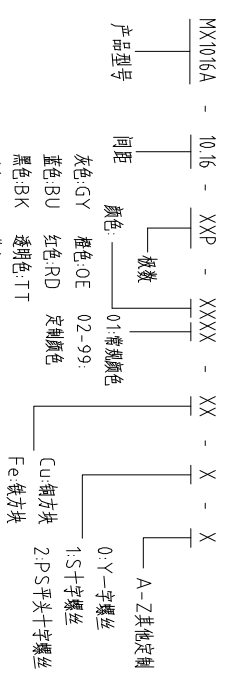

Pitch Range In mm	Nominal Dimension In mm	Range	Symbol
Over 6	Over 10	Over 30	0.1/10
TO 6	TO 10	TO 30	
Over 10	Over 24	Over 60	∠
TO 10	TO 24	TO 60	
±0.15	±0.20	±0.30	±2°
±0.30	±0.50	±1.00	

ITEM	NAME OF PART	NO. OF PART	Q'TY	MATERIAL	NOTE
DWG	CHK	DATE	UNITS	MM	SHEET/OF 1/1
APP	DATE	SCALE	SCALE	A4	1:1
CIXI MAIXU ELECTRONICS CO.,LTD			NAME	MX1016A-10.16-XXP	
慈溪市迈旭电子有限公司			DWGNO.		