

注：本板为禁止运输、复制、编辑文件，以及用其内容进行交流

REV	ECN NO.	CONTENT	CHK	DATE

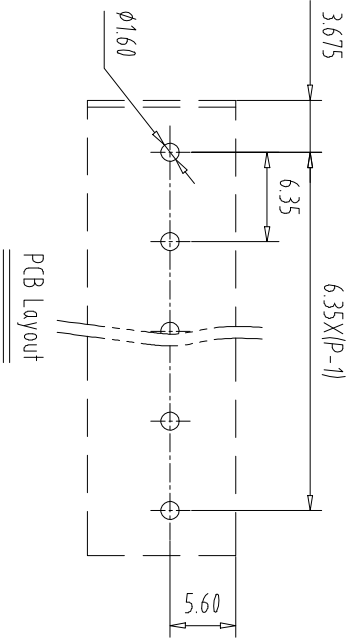
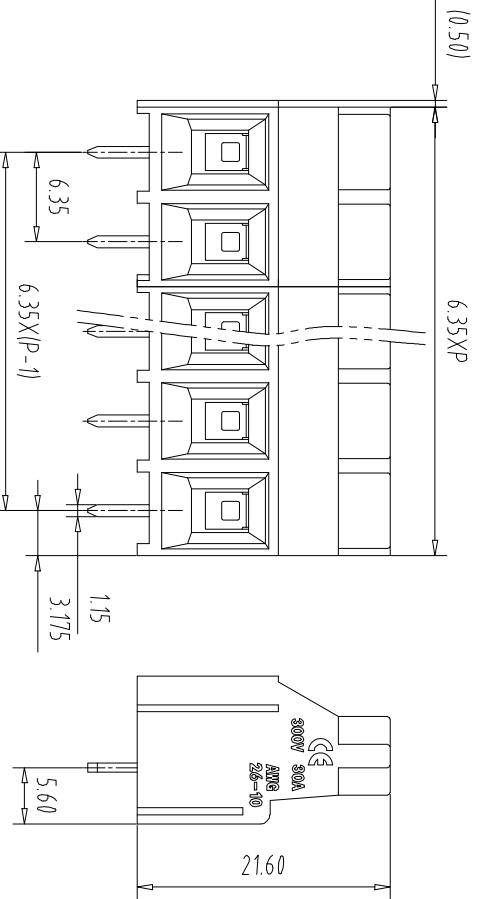
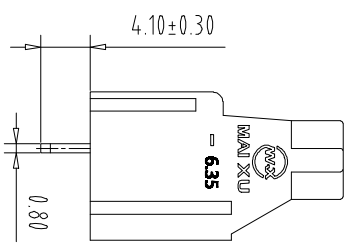
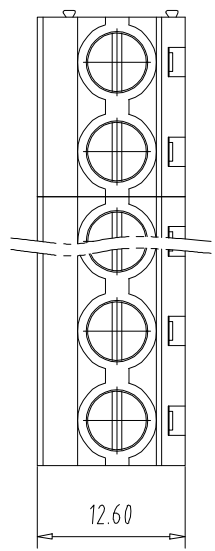

NOTES1:
 UL Standard
 1.Rating voltage/current: 300V/30A
 2.withstanding voltage: AC2500V/1Min
 3.Torque value: M3, 4.43Lb.in
 4.Wire range: 26~10AWG
 IEC Standard
 1.1.Rating voltage/current: 450V/32A
 2. Torque value: M3, 0.5Nm
 3.wire range: 15-4.0mm²

NOTES2:
 1.Housing: PA66(UL94V-0)
 2.Solder Pin: Copper alloy(Sn Plated)
 3.Cage: Brass(Ni Plated)
 4.Screw: Steel(M3,Zn Plated)

NOTES3:
 1.Pitch: 6.35mm Poles: 02-24P
 2.Stripping length: 7-8mm
 3.Operating temperature: -40℃~+105℃
 4.RoHS Compliance

How to order

MX635 - 635 - XXP - XXXX - XX - X - X
 产品型号 间距 颜色: 板数 01:常规颜色
 灰色:GY 橙色:OE 02-99:
 蓝色:BU 红色:RD 定制颜色
 黑色:BK 透明色:TT
 绿色:GN 黄色:YW
 透明色:TT 白色:WE
 A-Z其他定制
 0-Y-字螺丝
 1-S-字螺丝
 C-U:铜方块
 Fe:铁方块
 2-P-S-平头十字螺丝

Pitch Range In mm	Nominal Dimension Range In mm				Over 150	Over 1.50	Over 1.30
	Over 6 TO	Over 10 TO	Over 24 TO	Over 30 TO			
±0.15	±0.20	±0.30	±0.30	±0.50	±0.70	±1.00	±1.30

ITEM	NAME OF PART	NO. OF PART	Q-TY	MATERIAL	NOTE
DWG	CHK	DATE	UNITS	MM	SHEET/OF
APP	DATE	SCALE	1:1	A4	1/1
CIXI MAIXU ELECTRONICS CO.,LTD			NAME		
慈溪市迈旭电子有限公司			MX635-6.35-XXP		
DWGNO.			1		