

1. DESCRIPTION

The XL1050 is the interface between the Controller Area Network (CAN) protocol controller and the physical bus. It is primarily intended for high speed applications, up to 1 MBaud, in passenger cars. The device provides differential transmit capability to the bus and differential receive capability to the CAN controller.

2. FEATURES

- Fully compatible with the ISO 11898 standard
- High speed (up to 1 MBaud)
- Silent mode
- Differential receiver with high common-mode range for ElectroMagnetic Immunity (EMI)
- Transceiver in unpowered state disengages from the bus (zero load)
- At least 110 nodes can be connected
- Transmit Data (TXD) dominant time-out function
- Bus pins protected against transients in automotive environments
- Thermally protected
- Available in SOP8 small form factor package.

3. APPLICATIONS

- Automotive electronics
- Point-to-point and point-to-multipoint communications
- Industrial control automation
- Security systems
- Intelligent instrumentation
- Road traffic control automation
- Building automation systems
- Serial servers
- Level converter

4. PIN CONFIGURATIONS AND FUNCTIONS

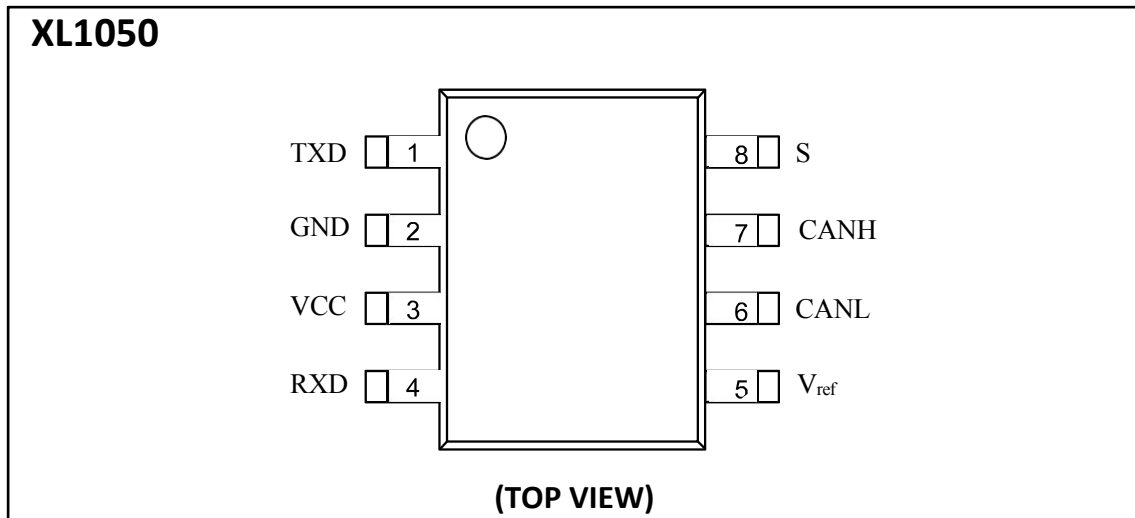

Pin Functions

Pin	SYMBOL	Description
1	TXD	transmit data input
2	GND	ground supply
3	VCC	supply voltage
4	RXD	receive data output; reads out data from the bus lines
5	Vref	Reference Voltage Output
6	CANL	LOW-level CAN bus line
7	CANH	HIGH-level CAN bus line
8	S	High speed and mute mode selection, low level for high speed

5. SPECIFICATIONS

5.1. Absolute Maximum Ratings

SYMBOL	PARAMETER	MIN	MAX	UNIT
VCC	Supply voltage range	-0.3	+6	V
TXD, RXD, STB, Vref	MCU Side Port	-0.3	VCC+0.3	V
CANL, CANH	Bus-side port voltage	-60	+60	V
Vtr	Pin 6, 7 Transient Voltage	-200	+200	V
	storage temperature	-55	150	°C
	ambient temperature	-40	125	°C
	Welding temperature range	-	300	°C

5.2. Bus Transmitter DC Characteristics

(VCC=5V±10%, Temp=TMIN~TMAX, typical values at VCC=+5V, Temp=25°C, unless otherwise noted)

SYMBOL	PARAMETER	TEST CONDITIONS	MIN	MAX	UNIT	SYMBOL
VOH(D)	CANH output voltage (dominant)	VI=0V, STB=0V, RL=60Ω, Figure 1、Figure 2	2.9	3.4	4.5	
VOL(D)	CANL output voltage (dominant)		0.8		1.5	
VO(R)	Bus Output Differential Voltage (implicit)	VI=3V, STB=0V, RL=60Ω, Figure 1、Figure 2	2	2.5	3	V
VOD(D)	Bus Output Differential Voltage (dominant)	VI=0V, STB=0V, RL=60Ω, Figure 1、Figure 2	1.5		3	V
VOD(R)	Bus Output Differential Voltage (implicit)	VI=3V, S=0V, Figure 1、Figure 2	-0.012		0.012	V
		VI=3V, STB=0V, NO LOAD	-0.5		0.05	V
Vdom(TX)sym	dominant output voltage symmetry	Vdom(TX)sym=VCC- VCANH - VCANL	-400		400	mV
VTXsym	Output Voltage Symmetry	VTXsym= VCANH + VCANL	0.9VCC		1.1VCC	V
VOC	Common mode output voltage	STB=0V, Figure 8	2	2.5	3	V
△VOC	Explicit and implicit common mode output voltage difference			30		mV
I _{OS}	Short-circuit output current	CANH=-12V, CANL=open, Figure 11	-105	-72		mA
VIL	Low Level Input			0.36	1	
I _{OS} I _{O(R)}	Short-circuit output current Hidden output current	CANH=-12V, CANL=open, Figure 11	-1	0.5		
		CANH=12V, CANL=open, Figure 11		71	105	
		-27V<CANH<32V 0<VCC<5.25V	-2.0		2.5	mA

5.3. Bus Transmitter Switch Characteristics

(VCC=5V±10%, Temp=TMIN~TMAX, typical values at VCC=+5V, Temp=25°C, unless otherwise noted)

SYMBOL	PARAMETER	TEST CONDITIONS	MIN	MAX	UNIT	SYMBOL
tPLH	Transmission delay (low to high)	STB=0V, Figure 4	25	65	120	ns
tPHL	Transmission delay (high to low)		25	45	90	ns
tr	Differential output rise delay time			25		ns
tf	Differential output fall delay time			50		ns
tEN	Enable time from listen mode to dominant	Figure 7			1	μs
t _{dom}	Explicit timeout	Figure 10	300	450	700	μs
t _{BUS}	Bus wake-up time		0.7		5	μs

5.4. Bus Receiver DC Parameters

(VCC=5V±10%, Temp=TMIN~TMAX, typical values at VCC=+5V, Temp=25°C, unless otherwise noted)

SYMBOL	PARAMETER	TEST CONDITIONS	MIN	MAX	UNIT	SYMBOL
V _{IT+}	Positive Input Threshold	S=0V, Figure 5		800	900	mV
V _{IT-}	Negative Input Threshold		500	650		
V _{HYS}	Comparator Threshold Hysteresis Interval		100	125		
V _{OH}	High Level Output Voltage	IO=-2mA, Figure 6	4	4.6		V
V _{OL}	Low Level Output Voltage	IO=2mA, Figure 6		0.2	0.4	V
I _(OFF)	Bus input current at power down	CANH or CANL=5V, Other pin=0V		165	125	μA
C _i	CANH, CANL input capacitance to ground			13		pF
C _{iD}	CANH, CANL Differential Input Capacitors			5		pF
R _{IN}	CANH, CANL Input Resistance	TXD=3V, STB=0V	15	30	40	KΩ
R _{iD}	CANH, CANL Differential Input Resistors		30		80	KΩ
R _{Imatch}	RI(CANH), RIN(CANL) mismatches	CANH=CANL	-3%		3%	
V _{COM}	Common mode voltage range		-12		12	V

5.5. Bus Receiver Switching Characteristics

(VCC=5V±10%, Temp=TMIN~TMAX, typical values at VCC=+5V, Temp=25°C, unless otherwise noted)

SYMBOL	PARAMETER	TEST CONDITIONS	MIN	MAX	UNIT	SYMBOL
tPLH	Propagation delay (low to high)	STB=0V or VCC, Figure 6	60	100	130	ns
tPHL	Propagation delay (high to low)		45	70	90	ns
tr	RXD signal rise time			8		ns
tf	RXD signal fall time			8		ns

5.6. Device Switching Characteristics

(VCC=5V±10%, Temp=TMIN~TMAX, typical values at VCC=+5V, Temp=25°C, unless otherwise noted)

SYMBOL	PARAMETER	TEST CONDITIONS	MIN	MAX	UNIT	SYMBOL
Td(LOOP1)	Loop delay 1, driver input to receiver output, implicit to explicit	STB=0V, Figure9	90		190	ns
Td(LOOP2)	Loop Delay 2, Driver Input to Receiver Output, Explicit to Implicit		90		190	ns

5.7. Over-temperature protection

(VCC=5V±10%, Temp=TMIN~TMAX, typical values at VCC=+5V, Temp=25°C, unless otherwise noted)

SYMBOL	PARAMETER	TEST CONDITIONS	MIN	MAX	UNIT	SYMBOL
Tj(sd)	Overtemperature shutdown		155	165	180	°C

5.8. TXD Pin Characteristics

(VCC=5V±10%, Temp=TMIN~TMAX, typical values at VCC=+5V, Temp=25°C, unless otherwise noted)

SYMBOL	PARAMETER	TEST CONDITIONS	MIN	MAX	UNIT	SYMBOL
I _{IH} (TXD)	TXD port high level input current	V _I =VCC	-2		2	μA
I _{IL} (TXD)	TXD Port Low Level Input Current	V _I =0	-50		-10	μA
I _O (off)	Current in TXD when VCC=0V	VCC=0V, TXD=5V			1	μA
V _{IH}	Input High Lower Limit		2		VCC+0.3	V
V _{IL}	Input Low Limit		-0.3		0.8	V
TXD _O	TXD Port Dangle Voltage			H		logic

5.9. Vref pin reference voltage output

(VCC=5V±10%, Temp=TMIN~TMAX, typical values at VCC=+5V, Temp=25°C, unless otherwise noted)

SYMBOL	PARAMETER	TEST CONDITIONS	MIN	MAX	UNIT	SYMBOL
Vref	Reference Output Voltage	-50uA<I _o <50uA	0.4V _{CC}		0.6V _{CC}	V

5.10. Power consumption characteristics

(VCC=5V±10%, Temp=TMIN~TMAX, typical values at VCC=+5V, Temp=25°C, unless otherwise noted)

SYMBOL	PARAMETER	TEST CONDITIONS	MIN	MAX	UNIT	SYMBOL
I _{CC}	Silent Mode Power Consumption	S=VCC, V _I =VCC		6	10	μA
	Dominant power consumption	V _I =0V, S=0V, LOAD=60Ω		50	70	mA
	Implicit power consumption	V _I =VCC, S=0V, NO LOAD		6	10	mA

5.11. Menu

Table 1 CAN Transceiver Truth

VCC	TXD ⁽¹⁾	STB ⁽¹⁾	CANH ⁽¹⁾	CANL ⁽¹⁾	BUS STATE	RXD ⁽¹⁾
4.5V~5.5V	L	L(or float)	H	L	dominant	L
4.5V~5.5V	H (or float)	X	0.5V _{CC}	0.5V _{CC}	implicit	H
4.5V~5.5V	X	H	0.5V _{CC}	0.5V _{CC}	implicit	H
0<VCC<4.5V	X	X	0V<VCANH<VCC	0V<VCANL<VCC	implicit	X

[1] H=high; L=low; X=no care

Table 2 Driver Function

INPUTS		OUTPUTS		Bus State
TXD ⁽¹⁾	STB ⁽¹⁾	CANH ⁽¹⁾	CANL ⁽¹⁾	
L	L(or float)	H	L	Dominate(dominant)
H (or floa)	X	Z	Z	Recessive(implicit)
X	H	Z	Z	Recessive(implicit)

[1] H=high; L=low; X=no care

Table 3 Receiver Function

V _{ID} =CANH-CANL	RXD ⁽¹⁾	Bus State ⁽¹⁾
V _{ID} ≥0.9V	L	Dominate(dominant)
0.5<V _{ID} <0.9V	?	?
V _{ID} ≤0.5V	H	Recessive (implicit)
Open	H	Recessive (implicit)

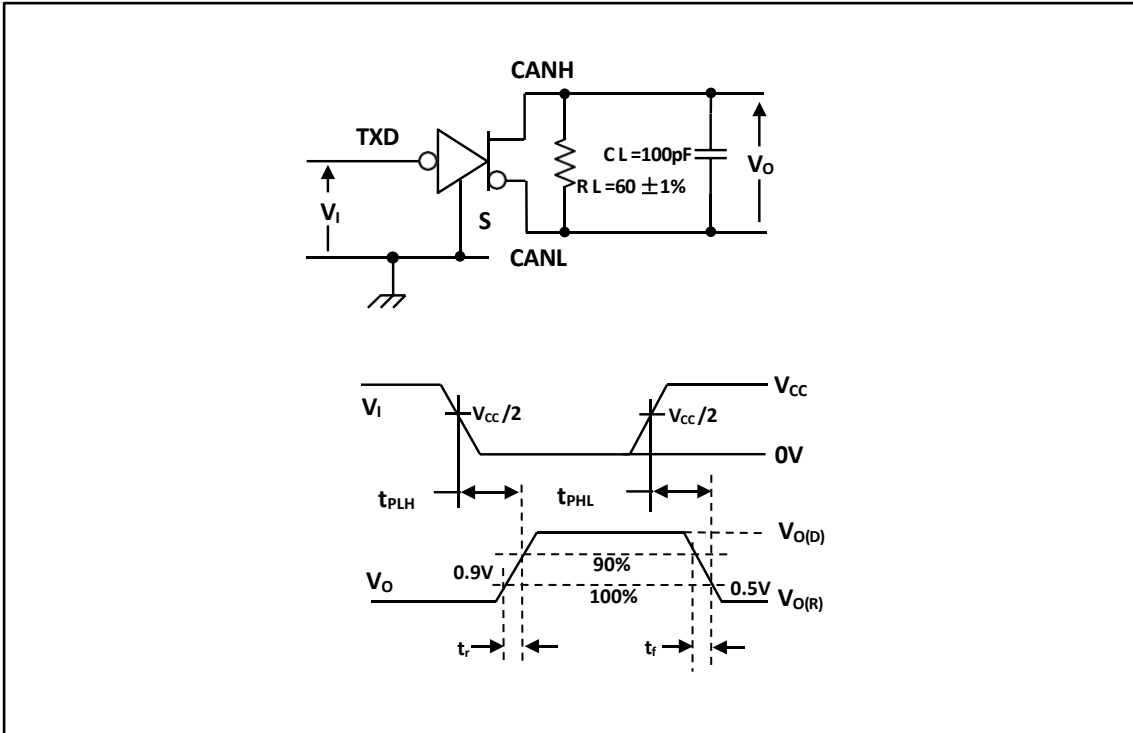

Figure 5-4. Driver Test Circuit and Voltage Waveforms

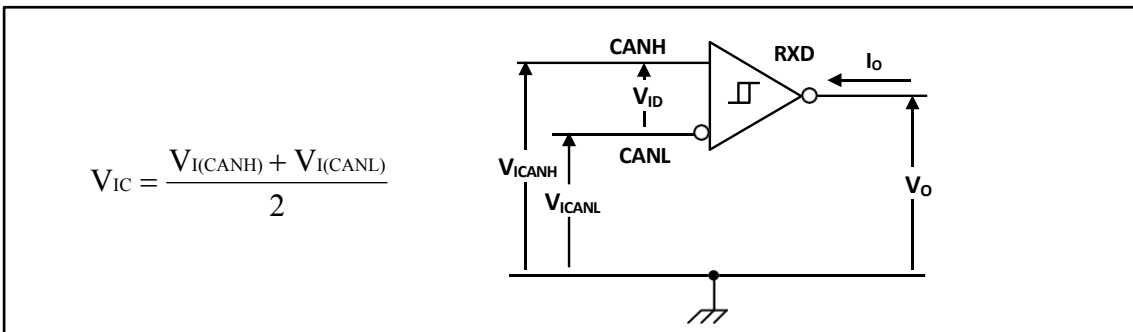

Figure 5-5. Receiver Voltage and Current Definitions

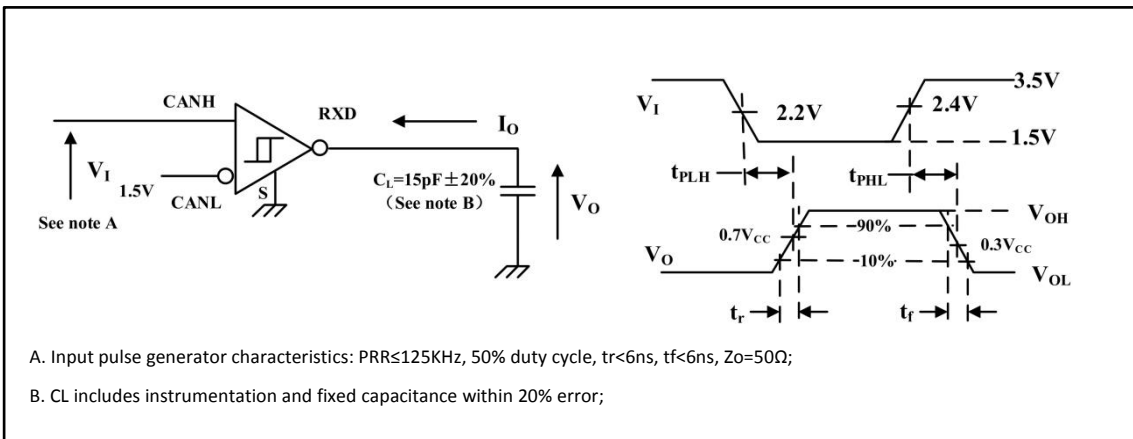

Figure 5-6. Receiver test circuit and voltage waveform

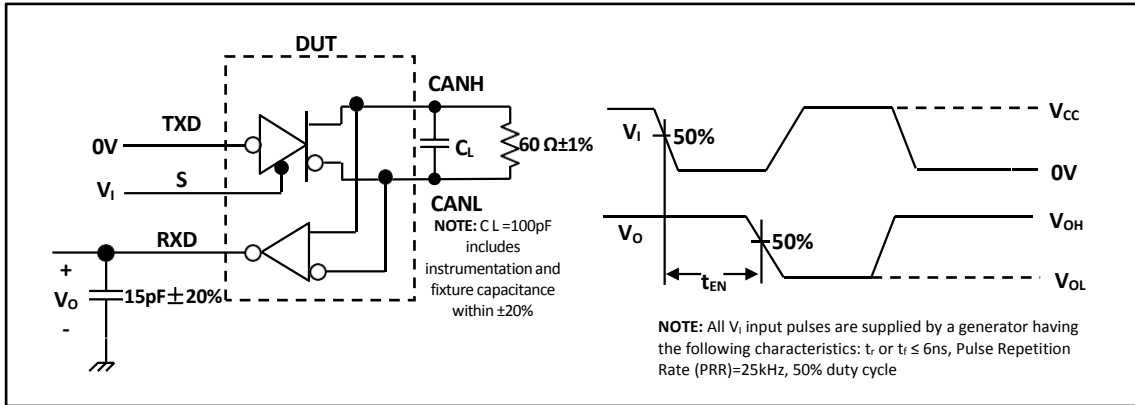

Figure 5-7. t_{EN} Test Circuit and Voltage Waveforms

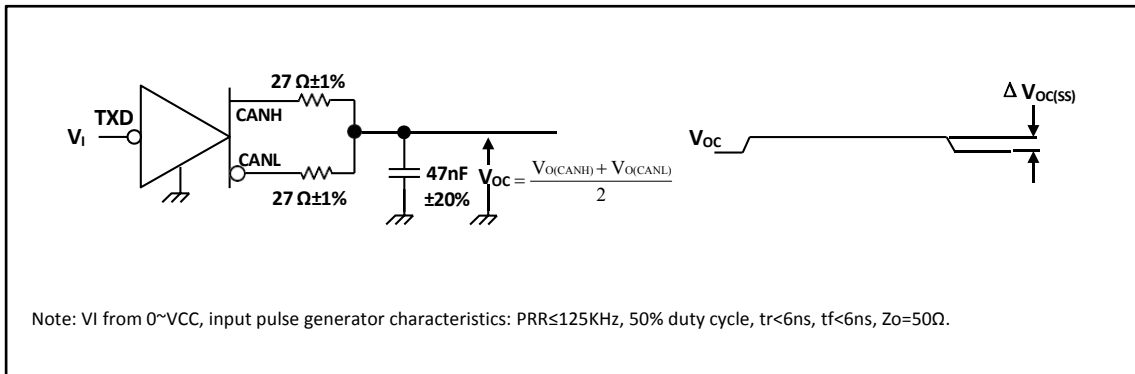

Figure 5-8. Common Mode Output Voltage Test and Waveforms

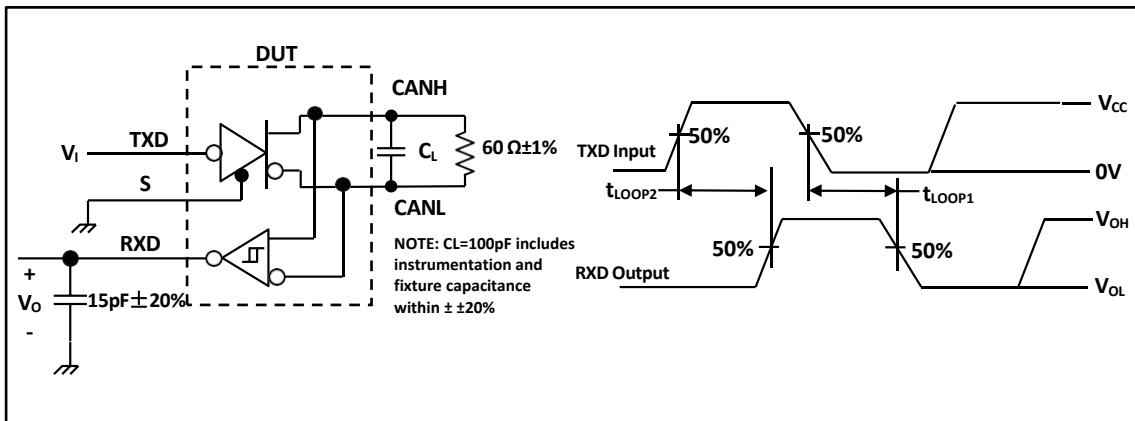

Figure 5-9. $t(\text{LOOP})$ Test Circuit and Waveforms

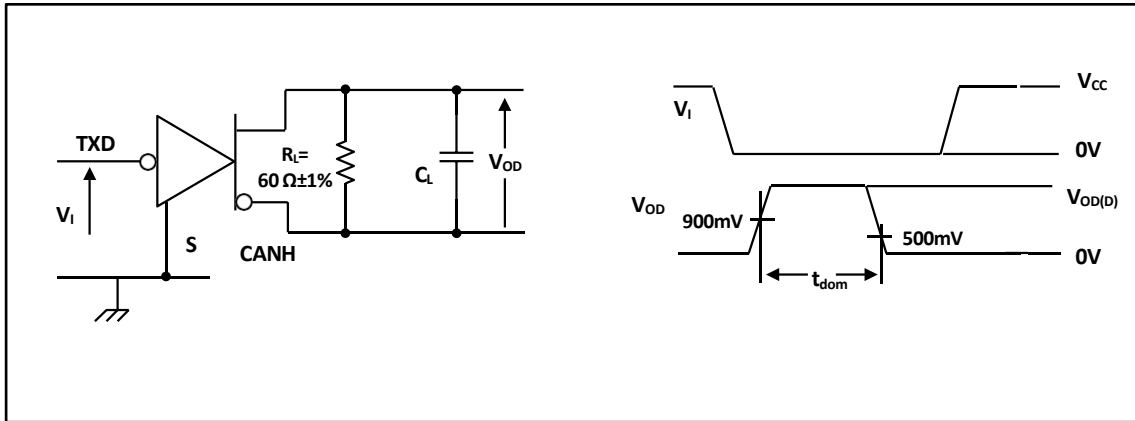

Figure 5-10. Revealed Timeout Test Circuit and Waveforms

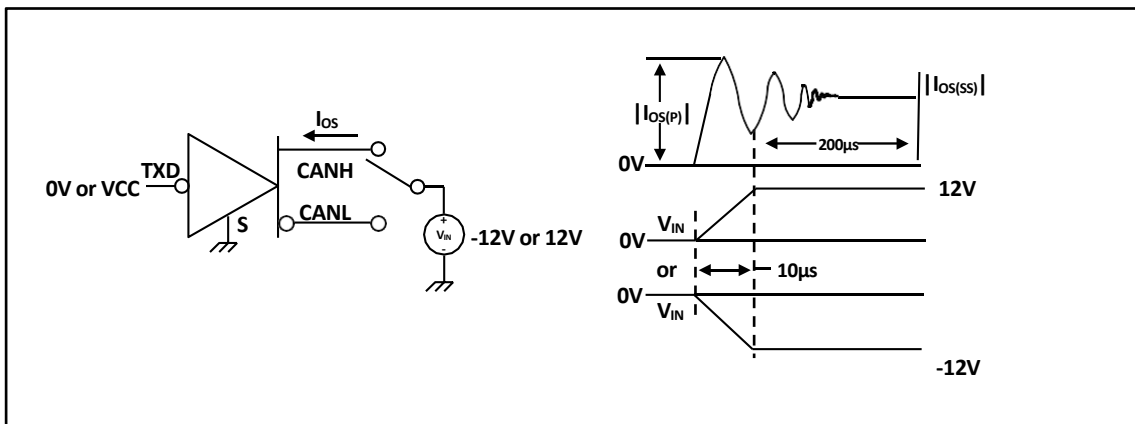

Figure 5-11. Driver Short Circuit Current Test Circuit and Waveforms

6. DESCRIPTION

6.1. Brief description

The XL1050 is an interface chip between the CAN protocol controller and the physical bus, which can be used in trucks, buses, cars, industrial control, etc. It can reach a speed of 1Mbps, and has the ability to transmit differential signals between the bus and the CAN protocol controller, and is fully compliant with the "ISO 11898" standard.

6.2. Short circuit protection

The driver stage of the XL1050 has current limiting protection to prevent the driver circuit from short-circuiting to positive and negative supply voltages. Power consumption increases when a short-circuit occurs, and the short-circuit protection feature protects the driver stage from damage.

6.3. Over Temperature Protection

The XL1050 has an over-temperature protection function. When the over-temperature protection is triggered, the current of the driver stage will be reduced because the driver tube is the main energy-consuming part, and the current reduction can reduce the power consumption and thus reduce the temperature of the chip. At the same time, the rest of the chip still works normally.

6.4. Significant Timeout Function

The built-in TXD dominant timeout timer circuit prevents the bus line from being driven to a permanently dominant state (blocking all network communications) if pin TXD is forced permanently low due to a hardware and/or software application failure. The timer is triggered by a negative edge on pin TXD.

If the duration of a low level on pin TXD exceeds the internal timer value (t_{dom}), the transmitter is disabled, driving the bus into a recessive state. The timer is reset by a positive edge on pin TXD.

6.5. Control Modes

Control pin S allows selection of two operating modes:

High Speed Mode or Silent Mode.

High speed mode is the normal mode of operation and is selected by grounding pin S. If pin S is not connected, it is the default mode. If pin S is not connected, it is the default mode. However, it is recommended that pin S be grounded to ensure EMI performance in applications that use only High Speed mode.

In silent mode, the transmitter is disabled. All other IC functions continue to operate. Silent mode is selected by connecting pin S to VCC and can be used to prevent network communication blocking due to a loss of CAN controller control.

7. ORDERING INFORMATION

Ordering Information

Part Number	Device Marking	Package Type	Body size (mm)	Temperature (°C)	MSL	Transport Media	Package Quantity
XL1050	XL1050	SOP8	4.90 * 3.90	-40 to +85	MSL3	T&R	2500

8. DIMENSIONAL DRAWINGS

