

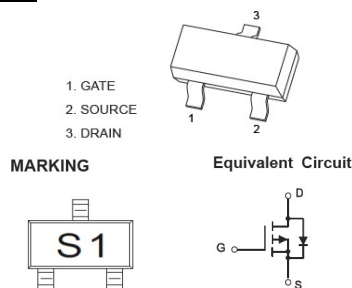

N-Channel Enhancement Mode Power MOSFET

V(BR)DSS	RDS(ON)MAX	ID
-20V	112mΩ@-4.5V	-2.3A
	142mΩ@-2.5V	

SOT-23



特征 Features

- TrenchFET Power MOSFET
- Load Switch for Portable Devices.
- DC/DC Converter.

机械数据 Mechanical Data

- 封装: SOT-23 封装 SOT-23 Small Outline Plastic Package.
- 环氧树脂 UL 易燃等级 Epoxy UL: 94V-0.
- 安装位置: 任意 Mounting Position: Any.

极限值和温度特性 (TA = 25°C 除非另有规定)

Maximum Ratings & Thermal Characteristics (Ratings at 25°C ambient temperature unless otherwise specified.)

参数 Parameters	符号 Symbol	数值 Value	单位 Unit
Drain-Source Voltage	V _{DS}	-20	V
Gate-Source Voltage	V _{GS}	±8	V
Continuous Drain Current	I _D	-2.3	A
Pulsed Drain Current	I _{DM}	-10	
Continuous Source-Drain Diode Current	I _S	-0.72	
Power Dissipation	P _D	400	mW
Junction Temperature	T _j	150	°C
Storage Temperature	T _{stg}	-50-+150	°C
Thermal Resistance From Junction to Ambient	R _{θJA}	312.5	°C/W

电特性 (TA = 25°C 除非另有规定)

Electrical Characteristics (Ratings at 25°C ambient temperature unless otherwise specified.)

参数 Parameter	符号 Symbols	测试条件 Test Condition	界限 Limits			单位 Unit
			Min	Typ	Max	
Static						
Drain-Source Breakdown Voltage	V(BR)DSS	V _{GS} =0V, I _D =-250uA	-20			V
Gate-Threshold voltage	V _{GS(th)}	V _{DS} =V _{GS} , I _D =-250uA	-0.4	-0.7	-1.0	V
Gate-body Leakage	I _{GSS}	V _{DS} =0V, V _{GS} =±8V			±100	nA
Zero Gate Voltage Drain current	I _{DSS}	V _{DS} =-20V, V _{GS} =0V			-1	uA
Drain-Source On-Resistance ^(a)	R _{DS(ON)}	V _{GS} =-4.5V, I _D =-2.8A		90	112	mΩ
		V _{GS} =-2.5V, I _C =-2A		110	142	
Forward trans conductance ^(a)	g _{fs}	V _{DS} =-5V, I _D =-2.8A		6.5		S
Dynamic^(b)						
Input capacitance	C _{iss}	V _{DS} =-10V, V _{GS} =0V, f=1MHz			405	pF
Output capacitance	C _{oss}				75	
Reverse Transfer capacitance	C _{rss}				55	
Total gate charge	Q _g	V _{DS} =-10V, V _{GS} =-4.5V, I _D =-3A		5.5	10	nC
Gate-source charge	Q _{gs}			3.3	6	
Gate-drain charge	Q _{gd}	V _{DS} =-10V, V _{GS} =-2.5V, I _D =-3A		0.7		
Gate resistance	R _g		F=1MHz		1.3	
Turn-on Time	td(on)	V _{DD} =-10V, R _L =10Ω, V _{GEN} =-4.5V, I _D =-1A, R _G =1Ω		11	20	ns
Rise time	tr			35	60	
Turn-off Time	td(off)			30	50	
Fall time	tf			10	20	
Drain-source body diode characteristics						
Continuous source-drain diode current	I _S	T _c =25°C			-3	A
Pulse diode forward current (a)	I _{SM}				-10	
Body diode voltage	V _{SD}	I _S =-0.7A,		-0.8	-1.2	V

Notes: a. Pulse Test: Pulse Width ≤300us, Duty Cycles≤2%.



N-Channel Enhancement Mode Power MOSFET

Typical characteristics

Output Characteristics

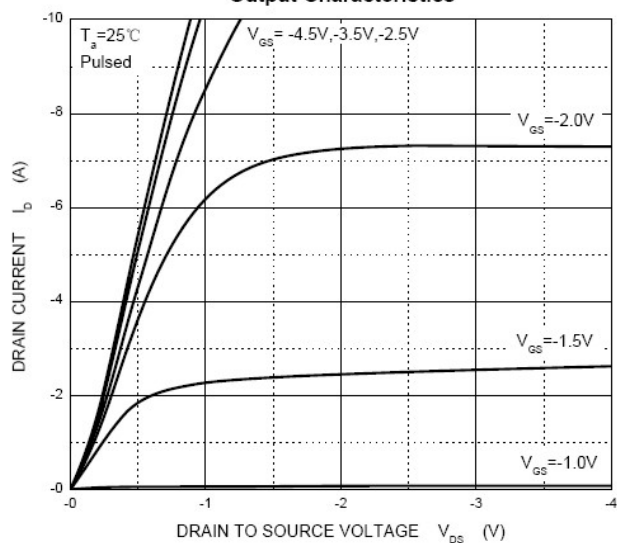

Transfer Characteristics

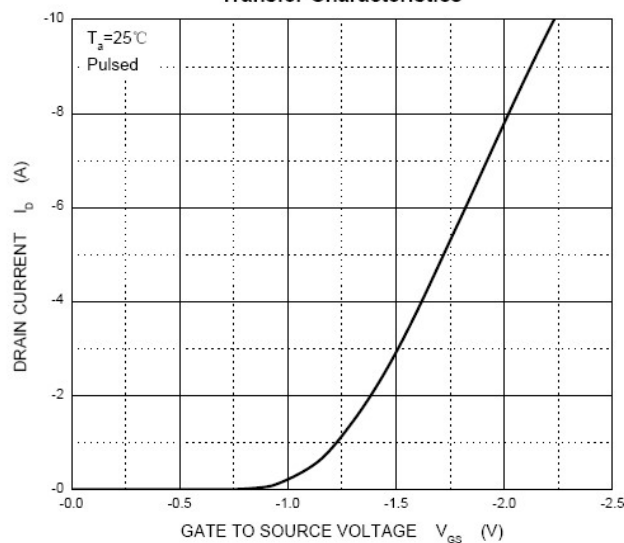

$R_{DS(ON)}$ — I_d

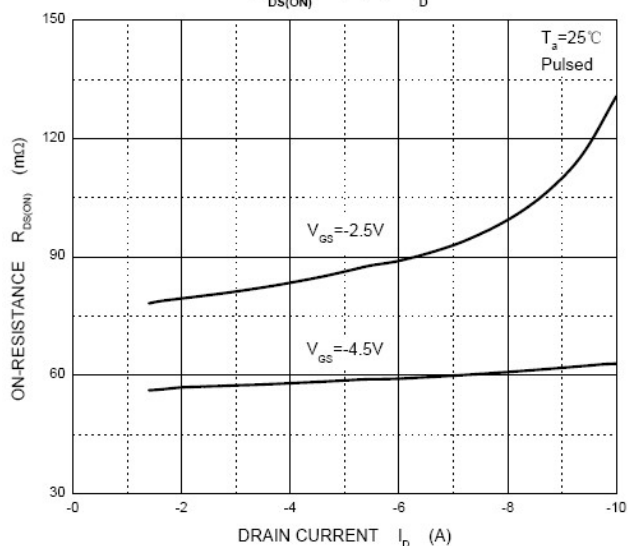

$R_{DS(ON)}$ — V_{gs}

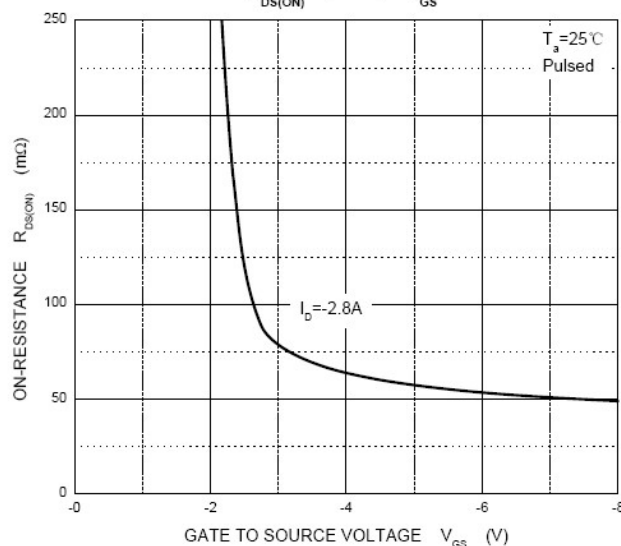

I_s — V_{SD}

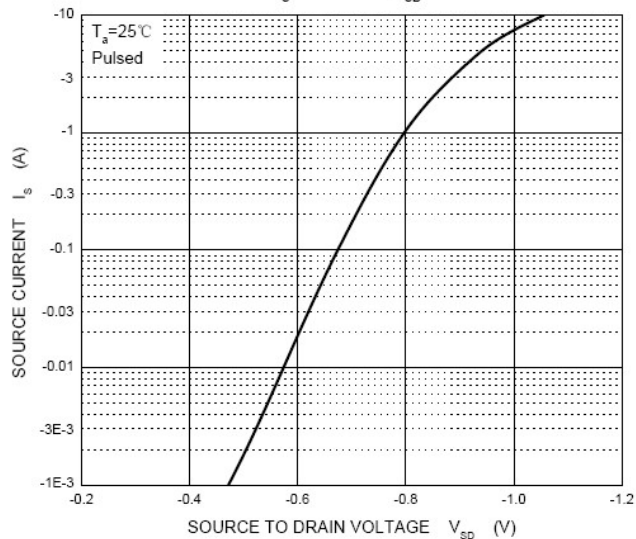



2301

N-Channel Enhancement Mode Power MOSFET

SOT-23 PACKAGE OUTLINE Plastic surface mounted package

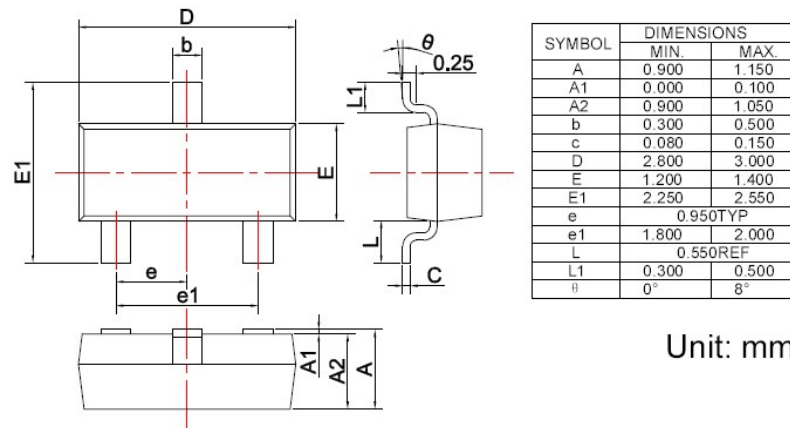

焊盘设计参考 Precautions: PCB Design

Recommended land dimensions for SOT-23 diode. Electrode patterns for PCBs

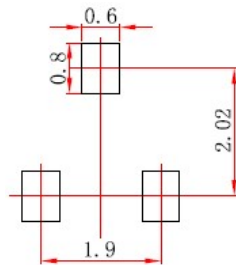

- Note:
1. Controlling dimension: In millimeters.
 2. General tolerance: ± 0.05mm.
 3. The pad layout is for reference purposes only.