



Version history

Current version	Date	Author	Change description

Metallized polyester film capacitor(Dipped)

■ Outline Drawing

	Forming Lead Shapes			
	I	II	III	IV
	$P \geq F$		$P < F$	
	$0\text{mm} \leq P-F \leq 3\text{mm}$	$3\text{mm} < P-F \leq 8\text{mm}$	$3\text{mm} < F-P \leq 5\text{mm}$	$0\text{mm} < F-P \leq 3\text{mm}$
	$F \pm 0.8\text{mm}; A \leq 5.0\text{mm}; B = 4.5 \pm 0.5\text{mm}$			

■ Features

- Metallized polyester film, non-inductive wound construction
- Small size and Excellent self-healing property
- Flame retardation epoxy resin coating (UL94/V-0)

■ Typical application

- As intermediate circuit capacitors for SMPS, Electronic Ballast, inverter (i.e. DC-link , DC-filter and P.F.C).

■ Specifications

Reference Standard	IEC 60384-2				
Climatic Category	55/105/21				
Rated temperature	85°C				
Operating temperature range	-55°C~105°C (+85°C to +105°C: decreasing factor 1.25% per °C for U_R)				
Rated Voltage	250V, 400V/450V, 520V, 630V				
Capacitance Range	0.010 μ F ~ 10.0 μ F				
Capacitance Tolerance	$\pm 5\%$ (J), $\pm 10\%$ (K), $\pm 20\%$ (M)				
Voltage Proof	1.6 U_R (5s)				
Dissipation Factor	$\leq 0.8\%$ (20°C,1kHz)				
Insulation Resistance	$R \geq 7500\text{M}\Omega$, $C_N \leq 0.33\mu\text{F}$ $RC_N \geq 2500\text{s}$, $C_N > 0.33\mu\text{F}$				
Maximum Pulse Rise Time(dV/dt) If the working voltage(U) is lower than the rated voltage(U_R),the capacitor can be worked at a higher dV/dt. In this case, the maximum allowed dV/dt is obtain by multiplying the right value with U_R/U .	U_R (V)	dV/dt (V/ μ s)			
		P=7.5	P=10.0	P=15.0	P=22.5
	250	80	60	50	30
	400/450	150	120	100	50
	520	200	180	150	80
630	350	300	200	100	



■ Part number system

The 15 digits part number is formed as follow:

1	2	3	4	5	6	7	8	9	10	11	12	13	14	15
C	2	2												

Digit 1 to 3 Series code

C22=CL21X

Digit 4 to 5 DC rated voltage

2E=250V 2G=400V 2S=450V

2T=520V 2J=630V

Digit 6 to 8 Rated capacitance value

For example : 103=10×10³ pF= 0.01μF

Digit 9 Capacitance tolerance

J=±5%,K=±10%, M=±20%

Digit 10 Lead pitch

3=7.5mm 4=10.0mm 6=15mm 9=22.5mm

Digit 11 Internal use

Digit 12 to 15 Lead form and packaging code

Table 1 lead form and packaging code

Digit 12		Digit 13		Digit 14		Digit 15	
code	explanation	code	explanation	code	explanation	code	explanation
A	ammo-pack	2	F=5.0mm	1	kinked	A	each cap. between two consecutive holes P3=12.7mm,H=20.0mm(For pitch=7.5mm)
		3	F=7.5mm				
		4	F=10.0mm			E	P3=25.4mm;H=20.0mm (For pitch=10.0/15.0mm)
		6	F=15.0mm				
F	lead kinked	2	F=5.0mm	0	B=4.5mm (the length of B)	0	B Length tolerance ±0.5mm
		3	F=7.5mm				
		4	F=10.0mm				
		6	F=15.0mm				
Y	straight lead “Y” in the figure above	code	explanation	0		0	Length tolerance ±0.5mm
		45	lead length 4.5mm				

Digit12-15 code “C000” means standard lead length (18mm ~ 30mm)

Note: Recommend short lead due to long lead could deform easily.



■ Dimensions (mm)

Miniature version

250Vdc						
C _N (μF)	W max	H max	T max	P	d	Part number
0.22	9.8	7.9	4.0	7.5	0.5	C222E224-3S****
0.27	9.8	8.8	4.1	7.5	0.5	C222E274-3S****
0.33	9.8	9.1	4.5	7.5	0.5	C222E334-3S****
0.47	9.8	11.4	5.0	7.5	0.5	C222E474-3S****
0.56	9.8	12.9	5.1	7.5	0.5	C222E564-3S****
0.68	9.8	13.4	5.6	7.5	0.5	C222E684-3S****
0.82	9.8	13.9	6.1	7.5	0.5	C222E824-3S****
1.00	9.8	14.5	6.7	7.5	0.5	C222E105-3S****
0.33	12.3	7.9	4.1	10.0	0.6	C222E334-4S****
0.47	12.3	9.6	4.2	10.0	0.6	C222E474-4S****
0.56	12.3	9.9	4.7	10.0	0.6	C222E564-4S****
0.68	12.3	10.3	5.1	10.0	0.6	C222E684-4S****
0.82	12.3	10.8	5.5	10.0	0.6	C222E824-4S****
1.00	12.3	11.3	6.1	10.0	0.6	C222E105-4S****

520Vdc						
C _N (μF)	W max	H max	T max	P	d	Part number
0.033	9.8	7.7	3.9	7.5	0.5	C222T333-3S****
0.047	9.8	8.8	4.1	7.5	0.5	C222T473-3S****
0.068	9.8	9.4	4.8	7.5	0.5	C222T683-3S****
0.10	9.8	10.8	5.8	7.5	0.5	C222T104-3S****
0.15	9.8	11.9	7.0	7.5	0.5	C222T154-3S****
0.068	12.3	8.7	4.0	10.0	0.6	C222T683-4S****
0.10	12.3	9.9	4.5	10.0	0.6	C222T104-4S****
0.15	12.3	10.7	5.3	10.0	0.6	C222T154-4S****
0.22	12.3	13.3	6.0	10.0	0.6	C222T224-4S****
0.33	12.3	14.6	7.3	10.0	0.6	C222T334-4S****

400Vdc/450Vdc [#]						
C _N (μF)	W max	H max	T max	P	d	Part number
0.047	9.8	6.9	3.7	7.5	0.5	C222G473-3S****
0.068	9.8	7.8	4.0	7.5	0.5	C222G683-3S****
0.082	9.8	8.7	4.0	7.5	0.5	C222G823-3S****
0.10	9.8	9.0	4.4	7.5	0.5	C222G104-3S****
0.12	9.8	9.3	4.7	7.5	0.5	C222G124-3S****
0.15	9.8	10.8	5.1	7.5	0.5	C222G154-3S****
0.18	9.8	11.2	5.5	7.5	0.5	C222G184-3S****
0.22	9.8	11.8	6.0	7.5	0.5	C222G224-3S****
0.27	9.8	12.4	6.6	7.5	0.5	C222G274-3S****
0.10	12.3	8.4	3.8	10.0	0.6	C222G104-4S****
0.12	12.3	8.7	4.0	10.0	0.6	C222G124-4S****
0.15	12.3	9.0	4.4	10.0	0.6	C222G154-4S****
0.18	12.3	9.4	4.7	10.0	0.6	C222G184-4S****
0.22	12.3	10.3	4.9	10.0	0.6	C222G224-4S****
0.27	12.3	10.8	5.4	10.0	0.6	C222G274-4S****
0.33	12.3	12.3	5.4	10.0	0.6	C222G334-4S****
0.47	12.3	13.9	6.6	10.0	0.6	C222G474-4S****
0.68	12.3	16.8	7.4	10.0	0.6	C222G684-4S****
0.82	12.3	17.5	8.2	10.0	0.6	C222G824-4S****
1.00	12.3	18.4	9.1	10.0	0.6	C222G105-4S****

- Note: 1. “_” =capacitance tolerance code, M=±20%,K=±10%,J=±5%
 2. “****” =lead form and packaging code (refer to table 1)
 3. “#” when the rated voltage is 450Vdc,the digit 4~5 is 2S.



■ Dimensions (mm)
Standard version

250Vdc							400Vdc/450Vdc [#]						
C _N (μF)	W max	H max	T max	P	d	Part number	C _N (μF)	W max	H max	T max	P	d	Part number
0.10	9.8	7.7	4.0	7.5	0.5	C222E104-30****	0.033	10.0	7.1	4.0	7.5	0.5	C222G333-30****
0.15	9.8	8.3	4.5	7.5	0.5	C222E154-30****	0.047	10.0	7.1	4.0	7.5	0.5	C222G473-30****
0.22	10.0	9.9	4.9	7.5	0.5	C222E224-30****	0.068	10.0	8.0	4.4	7.5	0.5	C222G683-30****
0.33	10.0	10.4	5.7	7.5	0.5	C222E334-30****	0.10	10.0	9.7	5.1	7.5	0.5	C222G104-30****
0.47	10.0	11.8	6.3	7.5	0.5	C222E474-30****	0.15	10.0	10.6	6.0	7.5	0.5	C222G154-30****
0.68	10.0	13.9	6.9	7.5	0.5	C222E684-30****	0.22	10.3	12.1	6.7	7.5	0.5	C222G224-30****
1.0	10.0	15.3	8.4	7.5	0.5	C222E105-30****	0.10	12.5	9.1	4.4	10.0	0.6	C222G104-40****
0.33	12.5	9.0	5.2	10.0	0.6	C222E334-40****	0.15	12.5	9.7	5.1	10.0	0.6	C222G154-40****
0.47	12.5	10.8	5.4	10.0	0.6	C222E474-40****	0.22	12.5	11.1	5.7	10.0	0.6	C222G224-40****
0.68	12.5	11.7	6.3	10.0	0.6	C222E684-40****	0.33	12.5	13.2	6.2	10.0	0.6	C222G334-40****
1.0	12.5	14.4	7.4	10.0	0.6	C222E105-40****	0.47	12.5	15.4	6.8	10.0	0.6	C222G474-40****
1.5	12.5	16.9	8.4	10.0	0.6	C222E155-40****	0.68	12.5	16.8	8.2	10.0	0.6	C222G684-40****
2.2	12.5	19.7	9.5	10.0	0.6	C222E225-40****	1.0	12.5	19.6	9.4	10.0	0.6	C222G105-40****
0.47	17.8	9.3	4.7	15.0	0.8	C222E474-60****	0.22	17.8	10.3	4.9	15.0	0.8	C222G224-60****
0.68	17.8	10.0	5.4	15.0	0.8	C222E684-60****	0.33	17.8	11.1	5.7	15.0	0.8	C222G334-60****
1.0	17.8	12.0	6.5	15.0	0.8	C222E105-60****	0.47	17.8	13.1	6.1	15.0	0.8	C222G474-60****
1.5	17.8	14.2	7.2	15.0	0.8	C222E155-60****	0.68	17.8	15.3	6.8	15.0	0.8	C222G684-60****
2.2	17.8	16.6	8.0	15.0	0.8	C222E225-60****	1.0	17.8	17.2	8.7	15.0	0.8	C222G105-60****
3.3	17.8	19.3	9.2	15.0	0.8	C222E335-60****	1.5	17.8	20.1	10.0	15.0	0.8	C222G155-60****
4.7	17.8	21.2	11.0	15.0	0.8	C222E475-60****	2.2	17.8	22.3	12.2	15.0	0.8	C222G225-60****
1.0	25.5	10.9	5.5	22.5	0.8	C222E105-90****	0.47	25.5	11.3	5.9	22.5	0.8	C222G474-90****
1.5	25.5	12.9	5.9	22.5	0.8	C222E155-90****	0.68	25.5	13.3	6.3	22.5	0.8	C222G684-90****
2.2	25.5	13.9	6.9	22.5	0.8	C222E225-90****	1.0	25.5	14.4	7.4	22.5	0.8	C222G105-90****
3.3	25.5	16.4	7.8	22.5	0.8	C222E335-90****	1.5	25.5	16.9	8.3	22.5	0.8	C222G155-90****
4.7	25.5	18.8	8.7	22.5	0.8	C222E475-90****	2.2	25.5	19.6	9.5	22.5	0.8	C222G225-90****
6.8	25.5	20.6	10.5	22.5	0.8	C222E685-90****	3.3	25.5	21.8	11.7	22.5	0.8	C222G335-90****
10.0	25.5	23.0	12.9	22.5	0.8	C222E106-90****							

- Note: 1. "-" =capacitance tolerance code, M=±20%,K=±10%,J=±5%
 2. "****" =lead form and packaging code (refer to table 1).
 3. "#" when the rated voltage is 450Vdc,the digit 4~5 is 2S.



■ Dimensions (mm)
Standard version

520Vdc							630Vdc						
C _N (μF)	W max	H max	T max	P	d	Part number	C _N (μF)	W max	H max	T max	P	d	Part number
0.022	9.8	7.5	4.0	7.5	0.5	C222T223-30****	0.010	9.8	7.6	4.1	7.5	0.5	C222J103-30****
0.033	9.8	8.5	4.4	7.5	0.5	C222T333-30****	0.015	9.8	7.6	4.1	7.5	0.5	C222J153-30****
0.047	9.8	9.6	4.7	7.5	0.5	C222T473-30****	0.022	9.8	8.1	4.6	7.5	0.5	C222J223-30****
0.068	9.8	10.4	5.4	7.5	0.5	C222T683-30****	0.033	9.8	9.2	5.1	7.5	0.5	C222J333-30****
0.068	12.5	9.6	4.7	10.0	0.6	C222T683-40****	0.047	9.8	10.5	5.5	7.5	0.5	C222J473-30****
0.10	12.5	10.9	5.5	10.0	0.6	C222T104-40****	0.068	9.8	11.9	6.2	7.5	0.5	C222J683-30****
0.15	12.5	11.9	6.5	10.0	0.6	C222T154-40****	0.10	9.8	13.1	7.7	7.5	0.5	C222J104-30****
0.22	12.5	14.1	7.1	10.0	0.6	C222T224-40****	0.047	12.5	9.6	4.6	10.0	0.6	C222J473-40****
0.33	12.5	15.6	8.6	10.0	0.6	C222T334-40****	0.068	12.5	10.3	5.3	10.0	0.6	C222J683-40****
0.10	17.8	9.4	4.7	15.0	0.8	C222T104-60****	0.10	12.5	11.2	6.5	10.0	0.6	C222J104-40****
0.15	17.8	10.2	5.5	15.0	0.8	C222T154-60****	0.15	12.5	13.9	6.9	10.0	0.6	C222J154-40****
0.22	17.8	11.6	6.1	15.0	0.8	C222T224-60****	0.22	12.5	15.3	8.3	10.0	0.6	C222J224-40****
0.33	17.8	13.7	6.7	15.0	0.8	C222T334-60****	0.10	17.8	10.6	5.1	15.0	0.8	C222J104-60****
0.47	17.8	14.9	7.9	15.0	0.8	C222T474-60****	0.15	17.8	12.5	5.5	15.0	0.8	C222J154-60****
0.68	17.8	17.5	8.9	15.0	0.8	C222T684-60****	0.22	17.8	13.5	6.5	15.0	0.8	C222J224-60****
1.0	17.8	20.9	10.7	15.0	0.8	C222T105-60****	0.33	17.8	14.8	7.8	15.0	0.8	C222J334-60****
1.5	17.8	23.4	13.2	15.0	0.8	C222T155-60****	0.47	17.8	16.3	9.2	15.0	0.8	C222J474-60****
0.33	25.5	12.4	5.4	22.5	0.8	C222T334-90****	0.68	17.8	19.1	10.4	15.0	0.8	C222J684-60****
0.47	25.5	13.3	6.3	22.5	0.8	C222T474-90****	1.0	17.8	22.8	12.6	15.0	0.8	C222J105-60****
0.68	25.5	15.5	7.0	22.5	0.8	C222T684-90****	1.5	17.8	25.8	15.6	15.0	0.8	C222J155-60****
1.0	25.5	18.5	8.4	22.5	0.8	C222T105-90****	0.22	25.5	11.2	5.7	22.5	0.8	C222J224-90****
1.5	25.5	20.4	10.3	22.5	0.8	C222T155-90****	0.33	25.5	12.2	6.7	22.5	0.8	C222J334-90****
2.2	25.5	22.6	12.5	22.5	0.8	C222T225-90****	0.47	25.5	14.3	7.3	22.5	0.8	C222J474-90****
							0.68	25.5	15.7	8.7	22.5	0.8	C222J684-90****
							1.0	25.5	20.0	9.8	22.5	0.8	C222J105-90****
							1.5	25.5	22.2	12.1	22.5	0.8	C222J155-90****
							2.2	25.5	24.9	14.8	22.5	0.8	C222J225-90****

- Note: 1. “-” =capacitance tolerance code, M=±20%,K=±10%,J=±5%
2. “****” =lead form and packaging code (refer to table 1).

■ Max current (I_{r.m.s}) versus frequency (Standard version)

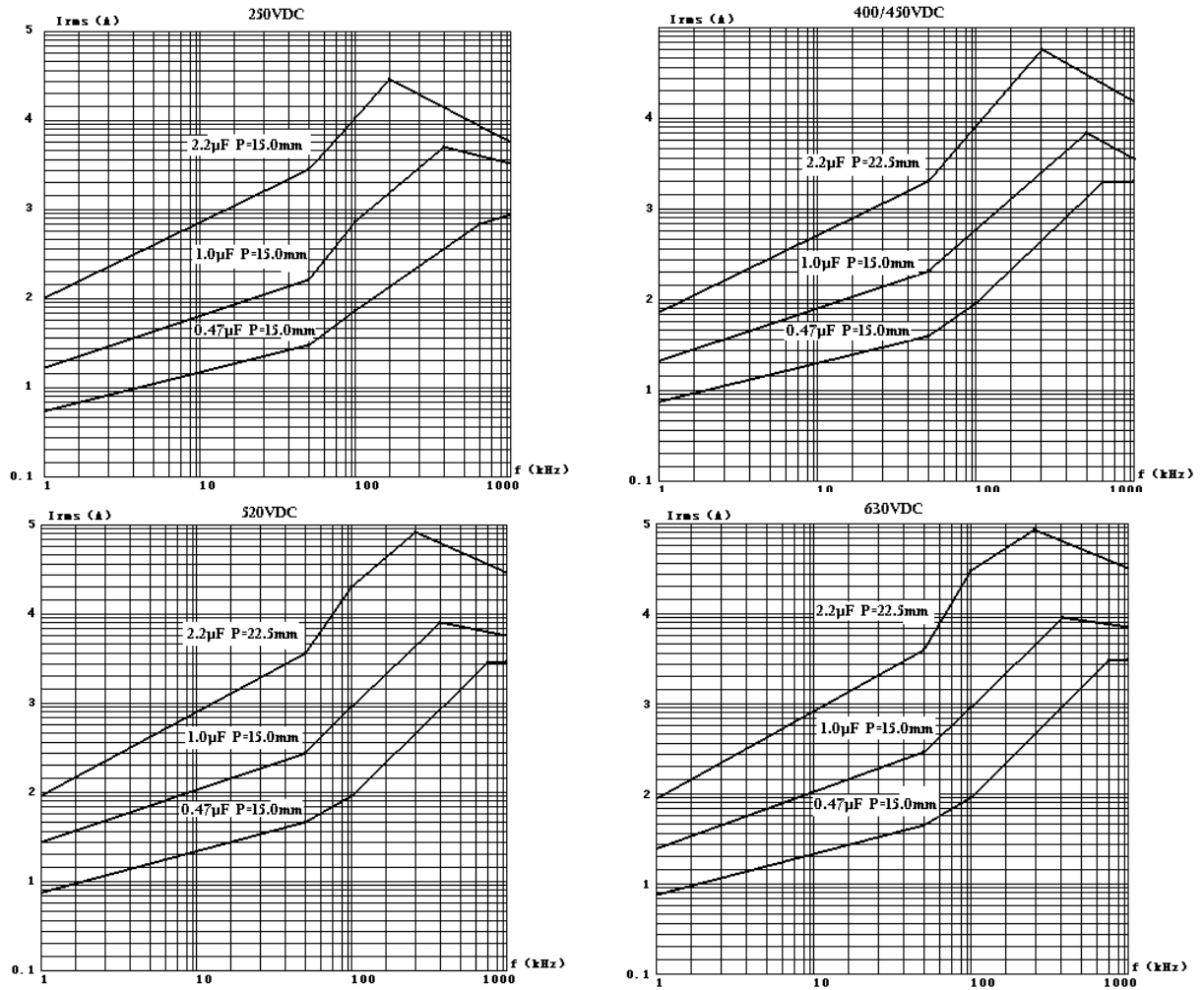

Note: 1.sinusoidal wave-form、 environment temperature $\leq 85^{\circ}\text{C}$, internal temperature rise $\Delta T=15^{\circ}\text{C}$, p (pitch) in mm.

2.The series product is only recommended to use in DC-filter or DC-blocking circuits. It means the voltage applied to the capacitors must be unidirectional ripple voltage. The typical voltage curve is as follows reference. If you have any questions for this note, please feel free to contact with our technical engineer.

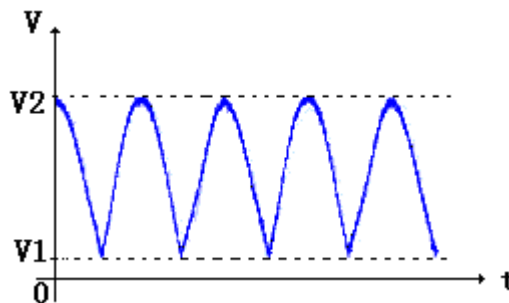

Here: $V_1 \geq 0$, $V_2 \leq U_R$, $I_{r.m.s} = 2 \pi f \times C \times (V_2 - V_1) \div \sqrt{2}$
 U_R is the rated voltage of the capacitor

■ Test Method And Performance

No.	Item	Performance	Test method (IEC60384-2)
1	Solderability	Good quality of tinning	Solder temperature:245°C±5°C Immersion time: 2.0s±0.5s
2	Initial measurement	Capacitance Tgδ: 1kHz, C>1.0μF 10kHz, C≤1.0μF	
	Terminal Strength (straight lead)	There shall be no visible damage	Ref. item 4.3 Tension: 0.6≤φd≤0.8mm, 10N φd=1.0mm, 20N Bend: 0.6≤φd≤0.8mm, 5N φd=1.0mm, 10N The terminals shall be bent 2 times in each direction.
	Resistance to solder heat	There shall be no visible damage	Solder temperature:260°C±5°C Immersion time: 10s±1s
	Final measurement	Δ C/C ≤ ± 2 % (relative to the initial value) Increase of tgδ: ≤0.005 (10kHz, C≤1.0μF) ≤0.003 (1kHz, C>1.0μF)	
3	Initial measurement	Capacitance Tgδ:1kHz, C>1.0μF 10kHz, C≤1.0μF	
	Rapid change of temperature	There shall be no evidence of deterioration.	θ _A =-55°C, θ _B =+105°C 5 cycles, Duration: t=30min
	Vibration(straight lead)	There shall be no evidence of deterioration.	Amplitude 0.75mm or acceleration 98m/s ² (whichever is the smaller severity), f: 10Hz to 500Hz.Three directions, 2h for each direction, total 6h.
	Bump(straight lead)	There shall be no evidence of deterioration.	4 000 times, Acceleration: 390m/s ² ,Pulse duration, 6ms
	Final measurement	Δ C/C ≤ ± 5 % (relative to the initial value) Increase of tgδ: ≤0.003 (10kHz, C≤1.0μF) ≤0.002 (1kHz, C>1.0μF) IR: ≥ 50% of the rated value	
4	climate sequence	Initial measurement	Capacitance Tgδ:1kHz, C>1.0μF 10kHz, C≤1.0μF
		Dry heat	+105°C,16h
		Damp,heat, Cyclic	Test Db, Severity: b, the first cycle
		Cold	-55°C, 2h
		Low air pressure	There shall be no permanent breakdown, flashover or other harmful deformation when applying U _R at the last 1 minute.
Damp,heat, cyclic other		Test Db, Severity b, the other cycles, Applying U _R for 1 minute after the test finished.	

No.	Item		Performance	Test method (IEC60384-2)
4	climate sequence (continue)	Final measurement	There shall be no evidence of deterioration and the marking shall be legible. $\Delta C/C \leq \pm 5\%$ (relative to the initial value) Increase of $\text{tg}\delta$: ≤ 0.005 (10kHz, $C \leq 1.0\mu\text{F}$) ≤ 0.003 (1kHz, $C > 1.0\mu\text{F}$) IR: $\geq 50\%$ of the rated value	
5	Damp heat steady state		There shall be no evidence of deterioration and the marking shall be legible. $\Delta C/C \leq \pm 5\%$ (relative to the initial value) Increase of $\text{tg}\delta \leq 0.005$ IR: $\geq 50\%$ of the rated value	Temperature: $40^\circ\text{C} \pm 2^\circ\text{C}$ Humidity: $93 \pm 3\%$ RH Duration: 21days
6	Endurance		$\Delta C/C \leq \pm 8\%$ (relative to the initial value) Increase of $\text{tg}\delta$: ≤ 0.003 (10kHz, $C \leq 1.0\mu\text{F}$) ≤ 0.002 (1kHz, $C > 1.0\mu\text{F}$) IR: $\geq 50\%$ of the rated value	Temperature: $+85^\circ\text{C}$ Voltage: $1.25 \times U_R$ Duration: 1 000h
7	Charging and discharging		$\Delta C/C \leq \pm 5\%$ (relative to the initial value) Increase of $\text{tg}\delta$: ≤ 0.003 (10kHz, $C \leq 1.0\mu\text{F}$) ≤ 0.002 (1kHz, $C > 1.0\mu\text{F}$) IR: $\geq 50\%$ of the rated value	Times: 10 000 Duration of charging: 0.5s Duration of discharging: 0.5s Charging voltage: rated voltage Charging resistance: $220/C_N(\Omega)$ Discharging resistance: $R = 10/C_N(\Omega)$ or 20Ω (whichever is the greater) C_N : rated capacitance (μF)

■ Marking (For example)

CL21X
104K 250

$P \leq 10\text{mm}$

CL21X
104K 250 L

$P > 10\text{mm}$

Marking Introduction:

	Brand	CL21X	Type
250	Rated voltage	104	Rated capacitance
K	Tolerance	L	Year of manufacture

■ Taping for dipped-type capacitor

▲ Outline Drawing

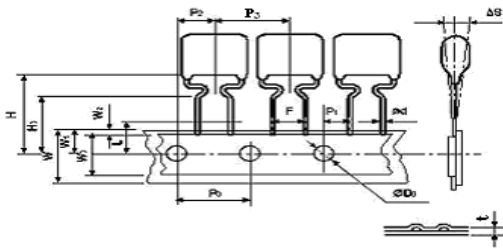

Fig.1

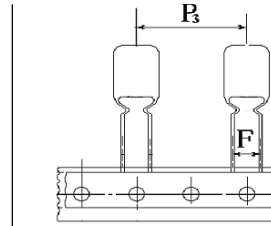

Fig 2

▲ Taping Dimensions(mm)

Technology index title	Code	Dimensions (mm)				Tolerance
		P=5.0	P=7.5	P=10.0	P=15.0	
Taping type	—	Fig 1	Fig 1	Fig 2	Fig 2	---
Part number Digit12-15	Ammo-pack	A21A	A31A	A41E	A61E	
Taping pitch	P ₃	12.7	12.7	25.4	25.4	±1.0
Feed hole pitch	P ₀	12.7	12.7	12.7	12.7	±0.3
Center of wire	P ₁	3.85	2.60	7.7	5.2	±0.7
Center of body	P ₂	6.35	6.35	12.7	12.7	±1.3
Pitch of taping wire	F**	5.0	7.5	10.0	15.0	+0.8 -0.2
Component alignment	△S	0	0	0	0	±2.0
Height of crangle from tape center	H	20.0	20.0	20.0	20.0	±1.0
Height of component from tape center	H ₀	16.0	16.0	16.0	16.0	±0.5
Carrier tape width	W	18.0	18.0	18.0	18.0	+1.0 -0.5
Hold down tape width	W ₀	10min	10min	10min	10min	---
Hole position	W ₁	9.0	9.0	9.0	9.0	+0.75 -0.5
Hold down tape position	W ₂	3max	3max	3max	3max	---
Feed hole dia.	D ₀	4.0	4.0	4.0	4.0	±0.3
Tape thickness	t	0.7	0.7	0.7	0.7	±0.2

Note: * P₀=15mm is also available;

** F can be other lead spacing;

■ Soldering suggestions

▲ Manual soldering

Max. temperature: 350°C, time: 3s

▲ Wave soldering

There are many factors affecting the heating of film capacitor during the wave soldering process, such as: preheating temperature, preheating time, soldering temperature, soldering time, other heat sources influence and so on.

The typical soldering profile is as below:

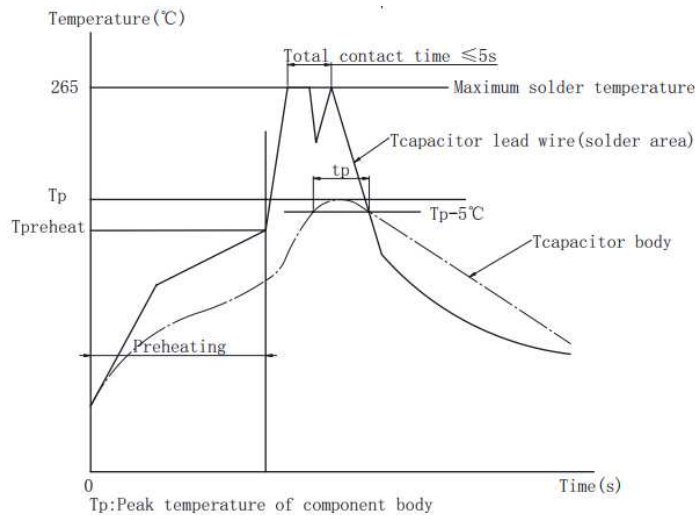

▲ Because overheating could damage the capacitor, we recommend paying attention to the maximum capacitor temperature and heating time, use temperature sensor to detect the maximum capacitor body temperature.

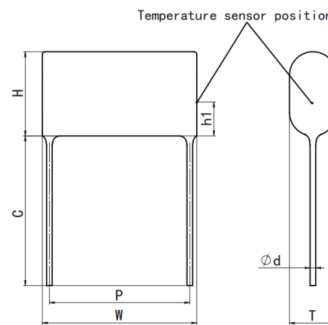

Note: If re-working or dipping twice is necessary, it should be done after the capacitor returns to

Temperature sensor position (Tcapacitor body)	The capacitor body surface of lead side, capacitor height position from PCB: h1=2~3mm		
Maximum capacitor body temperature Tp(°C)	OPP film P≤15mm	OPP film P>15mm	PET film
	115	120	125
Maximum capacitor lead wire temperature(°C)	265	265	265
Maximum capacitor body heating time tp=Tp-5°C	30s		

the normal temperature.

■ Packing box sizes(mm)(example)

1. Out packing box for bulk

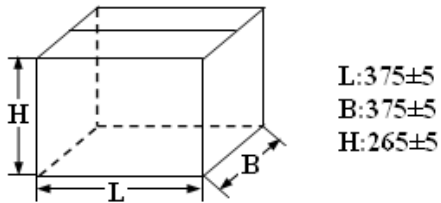

2. Inner packing box for bulk

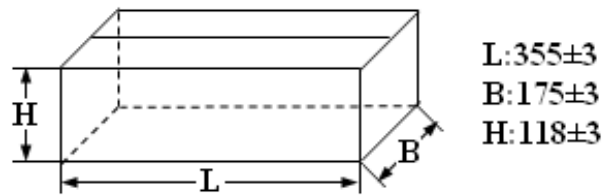

3. Box sizes for Ammo-pack

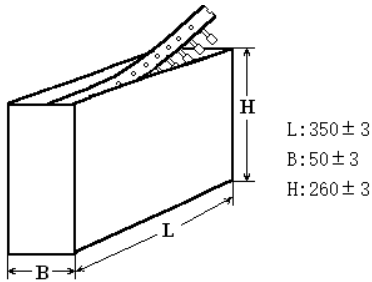

■ Storage conditions

▲ It must be noted that the solderability of the terminals may be deteriorated when stored in an atmosphere filled with moisture, dust, or a reactive oxidizing gas.(hydrogen chloride, hydrogen sulfide, sulfuric acid,etc.)

▲ It shouldn't be located in particularly high temperature and high humidity, it must submit to the following conditions(unchanging primal package):

Temperature: -40 °C to 35 °C

Humidity: Average per year ≤70%RH;

For 30 full days randomly distributed throughout the year ≤80%RH

Storage time for tinned lead wire: (from the date marked on the capacitor's body or the label glued to the package) :

Bulk(packed with plastic bag): ≤24 months ;

Taping and line up: ≤12 months