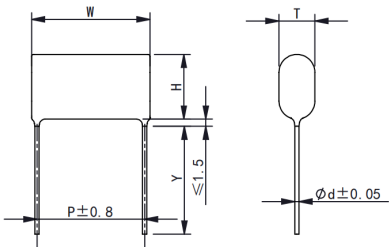
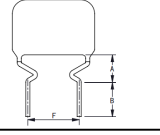
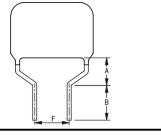
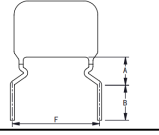
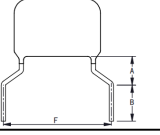

Version history

Current version	Date	Author	Change description

Metallized polypropylene film capacitor(dipped)

■ Outline Drawing

	Forming Lead Shapes			
	I	II	III	IV
				
	P ≥ F		P < F	
	0mm ≤ P-F ≤ 3mm	3mm < P-F ≤ 8mm	3mm < F-P ≤ 5mm	0mm < F-P ≤ 3mm
F ± 0.8mm; A ≤ 5.0mm; B = 4.5 ± 0.5mm				

■ Features

- Metallized polypropylene structure
- Low loss at high frequency
- Small inherent temperature rise
- Flame retardant epoxy resin powder coating (UL94/V-0)

■ Typical application

- Widely used in high frequency, DC, AC and pulse circuits
- Suitable for S-correction circuits of large screen monitor
- Suitable for the situation where applies high frequency and high current pulse

■ Specifications

Reference Standard	GB/T 10190(IEC 60384-16)				
Climatic Category	40/105/21				
Rated temperature	85°C				
Operating temperature	-40°C~105°C (+85°C to +105°C: decreasing factor 1.25% per °C for U _R)				
Rated Voltage	100V, 250V, 400V, 630V, 1000V, 1250V				
Capacitance Range	0.0010 ~ 3.3μF				
Capacitance Tolerance	±5%(J), ±10% (K), ±20% (M)				
Voltage Proof	1.6U _R (5s)				
Dissipation Factor	≤10 × 10 ⁻⁴ (20°C, 1kHz)				
Insulation Resistance	R ≥ 100 000MΩ, C _N ≤ 0.33μF RC _N ≥ 30 000s, C _N > 0.33μF (20°C, 100V, 1min)				
Maximum Pulse Rise Time(dV/dt) If the working voltage(U) is lower than the rated voltage(U _R),the capacitor can be worked at a higher dV/dt. In this case, the maximum allowed dV/dt is obtain by multiplying the right value with U _R /U.	Pattern II				
	U _R (V)	dV/dt(V/us)			
		P=7.5	P=10.0	P=15.0	P=22.5
	100/250	660	560	310	130
	400	900	780	600	300
630	1 500	1 200	900	400	
1 000/1 250	2 500	2 200	--	--	

■ Part number system

The 15 digits part number is formed as follow

1	2	3	4	5	6	7	8	9	10	11	12	13	14	15
C	3	1												

Digit 1 to 3 Series code

C31= CBB21

Digit 4 to 5 D.C. rated voltage

2A=100V 2E=250V 2G=400V

2J=630V 3A=1000V 3B=1250V

Digit 6 to 8 Rated capacitance value

 For example: 103=10×10³pF=0.01μF

Digit 9 Capacitance tolerance

J=±5%, K=±10%, M=±20%

Digit 10 Pitch

3=7.5mm 4=10mm 5=12.5mm 6=15mm

8=20mm 9=22.5mm A=25mm C=30mm

Digit 11 Internal use

S= Pattern II

Digit 12 to 15 Lead form and packaging code

Table 1 lead form and packing code

Digit 12		Digit 13		Digit 14		Digit 15	
code	explanation	code	explanation	code	explanation	code	explanation
A	ammo-pack	3	F=7.5mm	1	kinked	A	each cap. between two consecutive holes P3=12.7mm,H=20.0mm (For pitch=7.5mm)
		4	F=10.0mm			E	P3=25.4mm;H=20.0mm (For pitch=10.0/15.0mm)
F	lead kinked	6	F=15.0mm	0	B=4.5mm The length of B	0	B Length tolerance ±0.5mm
		7	F=17.5mm				
		8	F=20.0mm				
		9	F=22.5mm				
		code	explanation				
Y	straight lead “ Y ” in the figure above	45	lead length 4.5mm	0	Length tolerance ±0.5mm		
		code	explanation				

Digit12-15 code “C000” means standard lead length (18mm ~ 30mm)

Note: Recommend short lead due to long lead could deform easily.



■ Dimensions(mm)

Pattern II (Reduced sizes)

100Vdc(63Vac)/250Vdc(160Vac)#						
C _N (μF)	W max	H max	T max	P	d	Part number
0.010	9.8	7.7	4.0	7.5	0.6	C312A103-3S****
0.011	9.8	7.8	4.2	7.5	0.6	C312A113-3S****
0.012	9.8	7.9	4.3	7.5	0.6	C312A123-3S****
0.013	9.8	8.0	4.4	7.5	0.6	C312A133-3S****
0.015	9.8	7.8	4.2	7.5	0.6	C312A153-3S****
0.016	9.8	7.9	4.3	7.5	0.6	C312A163-3S****
0.018	9.8	8.1	4.4	7.5	0.6	C312A183-3S****
0.020	9.8	8.2	4.6	7.5	0.6	C312A203-3S****
0.022	9.8	8.4	4.8	7.5	0.6	C312A223-3S****
0.024	9.8	8.6	4.9	7.5	0.6	C312A243-3S****
0.027	9.8	7.6	4.0	7.5	0.6	C312A273-3S****
0.030	9.8	7.7	4.1	7.5	0.6	C312A303-3S****
0.033	9.8	7.9	4.2	7.5	0.6	C312A333-3S****
0.036	9.8	8.0	4.4	7.5	0.6	C312A363-3S****
0.039	9.8	8.1	4.5	7.5	0.6	C312A393-3S****
0.043	9.8	8.3	4.7	7.5	0.6	C312A433-3S****
0.047	9.8	8.5	4.8	7.5	0.6	C312A473-3S****
0.051	12.3	8.0	4.3	10.0	0.6	C312A513-4S****
0.056	12.3	8.1	4.5	10.0	0.6	C312A563-4S****
0.062	12.3	8.3	4.6	10.0	0.6	C312A623-4S****
0.068	12.3	8.5	4.8	10.0	0.6	C312A683-4S****
0.075	12.3	8.6	5.0	10.0	0.6	C312A753-4S****
0.082	12.3	8.8	5.2	10.0	0.6	C312A823-4S****
0.091	12.3	8.1	4.5	10.0	0.6	C312A913-4S****
0.10	12.3	8.3	4.7	10.0	0.6	C312A104-4S****
0.11	12.3	8.5	4.8	10.0	0.6	C312A114-4S****
0.12	12.3	8.6	5.0	10.0	0.6	C312A124-4S****
0.13	12.3	8.6	4.9	10.0	0.6	C312A134-4S****
0.15	12.3	8.9	5.2	10.0	0.6	C312A154-4S****
0.16	12.3	9.0	5.4	10.0	0.6	C312A164-4S****
0.18	12.3	9.3	5.6	10.0	0.6	C312A184-4S****
0.20	12.3	9.5	5.9	10.0	0.6	C312A204-4S****
0.22	12.3	9.8	6.1	10.0	0.6	C312A224-4S****
0.24	12.3	10.0	6.4	10.0	0.6	C312A244-4S****
0.27	17.5	10.5	5.3	15.0	0.6	C312A274-6S****
0.30	17.5	10.8	5.5	15.0	0.6	C312A304-6S****
0.33	17.5	11.0	5.8	15.0	0.6	C312A334-6S****
0.36	17.5	11.2	6.0	15.0	0.6	C312A364-6S****
0.39	17.5	11.4	6.2	15.0	0.6	C312A394-6S****
0.43	17.5	11.6	6.4	15.0	0.6	C312A434-6S****
0.47	17.5	11.9	6.6	15.0	0.6	C312A474-6S****
0.51	17.5	12.1	6.9	15.0	0.6	C312A514-6S****
0.56	17.5	12.4	7.2	15.0	0.6	C312A564-6S****
0.62	17.5	12.7	7.5	15.0	0.8	C312A624-6S****
0.68	17.5	13.5	7.8	15.0	0.8	C312A684-6S****
0.75	17.5	13.9	8.2	15.0	0.8	C312A754-6S****
0.82	17.5	14.2	8.5	15.0	0.8	C312A824-6S****
0.91	17.5	14.9	8.9	15.0	0.8	C312A914-6S****
1.0	17.5	15.0	9.3	15.0	0.8	C312A105-6S****
1.1	17.5	15.5	9.7	15.0	0.8	C312A115-6S****
1.2	25.2	14.8	7.5	22.5	0.8	C312A125-9S****
1.3	25.2	15.1	7.8	22.5	0.8	C312A135-9S****
1.5	25.2	15.6	8.3	22.5	0.8	C312A155-9S****
1.6	25.2	15.9	8.6	22.5	0.8	C312A165-9S****
1.8	25.2	16.4	9.1	22.5	0.8	C312A185-9S****
2.0	25.2	16.9	10.1	22.5	0.8	C312A205-9S****
2.2	25.2	18.3	9.9	22.5	0.8	C312A225-9S****
2.4	25.2	18.7	10.4	22.5	0.8	C312A245-9S****
2.7	25.2	19.3	10.9	22.5	0.8	C312A275-9S****
3.0	25.2	19.9	11.6	22.5	0.8	C312A305-9S****
3.3	25.2	20.5	12.1	22.5	0.8	C312A335-9S****

400Vdc(200Vac)						
C _N (μF)	W max	H max	T max	P	d	Part number
0.010	9.8	7.8	4.1	7.5	0.6	C312G103-3S****
0.011	9.8	7.9	4.2	7.5	0.6	C312G113-3S****
0.012	9.8	8.0	4.4	7.5	0.6	C312G123-3S****
0.013	9.8	8.1	4.5	7.5	0.6	C312G133-3S****
0.015	9.8	8.4	4.7	7.5	0.6	C312G153-3S****
0.016	9.8	8.5	4.8	7.5	0.6	C312G163-3S****
0.018	9.8	8.7	5.0	7.5	0.6	C312G183-3S****
0.020	9.8	8.9	5.3	7.5	0.6	C312G203-3S****
0.022	9.8	9.1	5.5	7.5	0.6	C312G223-3S****
0.024	12.3	8.0	4.3	10.0	0.6	C312G243-4S****
0.027	12.3	8.1	4.5	10.0	0.6	C312G273-4S****
0.030	12.3	8.3	4.7	10.0	0.6	C312G303-4S****
0.033	12.3	8.5	4.8	10.0	0.6	C312G333-4S****
0.036	12.3	8.6	5.0	10.0	0.6	C312G363-4S****
0.039	12.3	8.7	5.0	10.0	0.6	C312G393-4S****
0.043	12.3	8.8	5.2	10.0	0.6	C312G433-4S****
0.047	12.3	9.0	5.4	10.0	0.6	C312G473-4S****
0.051	12.3	9.2	5.6	10.0	0.6	C312G513-4S****
0.056	12.3	9.4	5.8	10.0	0.6	C312G563-4S****
0.062	12.3	8.9	5.2	10.0	0.6	C312G623-4S****
0.068	12.3	9.1	5.4	10.0	0.6	C312G683-4S****
0.075	12.3	9.3	5.7	10.0	0.6	C312G753-4S****
0.082	12.3	9.5	5.9	10.0	0.6	C312G823-4S****
0.091	12.3	9.8	6.1	10.0	0.6	C312G913-4S****
0.10	12.3	10.0	6.4	10.0	0.6	C312G104-4S****
0.11	12.3	10.3	6.6	10.0	0.6	C312G114-4S****
0.12	17.5	10.7	5.5	15.0	0.6	C312G124-6S****
0.13	17.5	10.9	5.7	15.0	0.6	C312G134-6S****
0.15	17.5	11.2	6.0	15.0	0.6	C312G154-6S****
0.16	17.5	11.3	6.1	15.0	0.6	C312G164-6S****
0.18	17.5	11.6	6.4	15.0	0.6	C312G184-6S****
0.20	17.5	11.9	6.7	15.0	0.6	C312G204-6S****
0.22	17.5	12.2	7.0	15.0	0.6	C312G224-6S****
0.24	17.5	12.5	7.3	15.0	0.6	C312G244-6S****
0.27	17.5	12.9	7.6	15.0	0.8	C312G274-6S****
0.30	17.5	13.7	8.0	15.0	0.8	C312G304-6S****
0.33	17.5	14.1	8.4	15.0	0.8	C312G334-6S****
0.36	17.5	14.4	8.7	15.0	0.8	C312G364-6S****
0.39	17.5	14.7	9.0	15.0	0.8	C312G394-6S****
0.43	17.5	15.1	9.4	15.0	0.8	C312G434-6S****
0.47	17.5	15.5	9.8	15.0	0.8	C312G474-6S****
0.51	25.2	14.8	7.6	22.5	0.8	C312G514-9S****
0.56	25.2	15.2	7.9	22.5	0.8	C312G564-9S****
0.62	25.2	15.6	8.3	22.5	0.8	C312G624-9S****
0.68	25.2	15.9	9.1	22.5	0.8	C312G684-9S****
0.75	25.2	16.3	9.6	22.5	0.8	C312G754-9S****
0.82	25.2	16.7	10.0	22.5	0.8	C312G824-9S****
0.91	25.2	17.2	10.5	22.5	0.8	C312G914-9S****
1.0	25.2	17.7	10.9	22.5	0.8	C312G105-9S****

- Note: 1. “-” =capacitance tolerance code, M=±20%,K=±10%,J=±5%
 2. “****” =lead form and packing code (refer to table 1)
 3. “#” when the rated voltage is 250Vdc,the digit 4~5 is 2E.



■ Dimensions(mm)
Pattern II (Reduced sizes)

630Vdc(220Vac) [®]							630Vdc(220Vac) [®]							1 000/1 250Vdc (400Vac) [*]						
C _N (μF)	W max	H max	T max	P	d	Part number	C _N (μF)	W max	H max	T max	P	d	Part number	C _N (μF)	W max	H max	T max	P	d	Part number
0.0010	10.0	7.9	4.3	7.5	0.6	C312J102-3S****	0.027	12.3	9.4	5.7	10.0	0.6	C312J273-4S****	0.0010	10.0	7.9	4.3	7.5	0.6	C313A102-3S****
0.0011	10.0	8.1	4.4	7.5	0.6	C312J112-3S****	0.030	12.3	9.6	6.0	10.0	0.6	C312J303-4S****	0.0011	10.0	8.1	4.4	7.5	0.6	C313A112-3S****
0.0012	10.0	8.2	4.5	7.5	0.6	C312J122-3S****	0.033	12.3	9.9	6.2	10.0	0.6	C312J333-4S****	0.0012	10.0	8.2	4.5	7.5	0.6	C313A122-3S****
0.0013	10.0	8.3	4.7	7.5	0.6	C312J132-3S****	0.036	12.3	10.1	6.4	10.0	0.6	C312J363-4S****	0.0013	10.0	8.3	4.7	7.5	0.6	C313A132-3S****
0.0015	10.0	8.1	4.4	7.5	0.6	C312J152-3S****	0.039	12.3	10.3	6.7	10.0	0.6	C312J393-4S****	0.0015	10.0	8.1	4.4	7.5	0.6	C313A152-3S****
0.0016	10.0	8.2	4.5	7.5	0.6	C312J162-3S****	0.043	17.5	10.7	5.4	15.0	0.6	C312J433-6S****	0.0016	10.0	8.2	4.5	7.5	0.6	C313A162-3S****
0.0018	10.0	7.8	4.2	7.5	0.6	C312J182-3S****	0.047	17.5	10.8	5.6	15.0	0.6	C312J473-6S****	0.0018	10.0	7.8	4.2	7.5	0.6	C313A182-3S****
0.0020	10.0	8.0	4.3	7.5	0.6	C312J202-3S****	0.051	17.5	11.0	5.8	15.0	0.6	C312J513-6S****	0.0020	10.0	8.0	4.3	7.5	0.6	C313A202-3S****
0.0022	10.0	8.1	4.5	7.5	0.6	C312J222-3S****	0.056	17.5	11.2	6.0	15.0	0.6	C312J563-6S****	0.0022	10.0	8.1	4.5	7.5	0.6	C313A222-3S****
0.0024	9.8	8.0	4.3	7.5	0.6	C312J242-3S****	0.062	17.5	11.4	6.2	15.0	0.6	C312J623-6S****	0.0024	10.0	7.7	4.0	7.5	0.6	C313A242-3S****
0.0027	9.8	8.1	4.5	7.5	0.6	C312J272-3S****	0.068	17.5	11.7	6.5	15.0	0.6	C312J683-6S****	0.0027	10.0	7.8	4.2	7.5	0.6	C313A272-3S****
0.0030	9.8	8.3	4.7	7.5	0.6	C312J302-3S****	0.075	17.5	11.9	6.7	15.0	0.6	C312J753-6S****	0.0030	10.0	8.0	4.4	7.5	0.6	C313A302-3S****
0.0033	9.8	8.5	4.8	7.5	0.6	C312J332-3S****	0.082	17.5	12.2	7.0	15.0	0.6	C312J823-6S****	0.0033	10.0	8.2	4.5	7.5	0.6	C313A332-3S****
0.0036	9.8	8.0	4.4	7.5	0.6	C312J362-3S****	0.091	17.5	12.5	7.3	15.0	0.6	C312J913-6S****	0.0036	10.0	8.3	4.7	7.5	0.6	C313A362-3S****
0.0039	9.8	8.2	4.5	7.5	0.6	C312J392-3S****	0.10	17.5	12.8	7.6	15.0	0.8	C312J104-6S****	0.0039	10.0	8.4	4.8	7.5	0.6	C313A392-3S****
0.0043	9.8	8.3	4.7	7.5	0.6	C312J432-3S****	0.11	17.5	13.6	7.9	15.0	0.8	C312J114-6S****	0.0043	10.0	8.2	4.5	7.5	0.6	C313A432-3S****
0.0047	9.8	8.5	4.9	7.5	0.6	C312J472-3S****	0.12	17.5	13.9	8.2	15.0	0.8	C312J124-6S****	0.0047	10.0	8.3	4.7	7.5	0.6	C313A472-3S****
0.0051	9.8	8.6	5.0	7.5	0.6	C312J512-3S****	0.13	17.5	14.2	8.5	15.0	0.8	C312J134-6S****	0.0051	10.0	8.5	4.8	7.5	0.6	C313A512-3S****
0.0056	9.8	8.8	5.2	7.5	0.6	C312J562-3S****	0.15	17.5	14.7	9.0	15.0	0.8	C312J154-6S****	0.0056	10.0	8.7	5.0	7.5	0.6	C313A562-3S****
0.0062	9.8	9.0	5.4	7.5	0.6	C312J622-3S****	0.16	17.5	15.0	9.3	15.0	0.8	C312J164-6S****	0.0062	10.0	8.7	5.0	7.5	0.6	C313A622-3S****
0.0068	12.3	8.0	4.4	10.0	0.6	C312J682-4S****	0.18	17.5	15.5	9.8	15.0	0.8	C312J184-6S****	0.0068	12.0	8.9	5.2	10.0	0.6	C313A682-4S****
0.0075	12.3	8.2	4.5	10.0	0.6	C312J752-4S****	0.20	17.5	16.0	10.3	15.0	0.8	C312J204-6S****	0.0075	12.0	9.1	5.4	10.0	0.6	C313A752-4S****
0.0082	12.3	8.3	4.7	10.0	0.6	C312J822-4S****	0.22	25.2	15.2	7.9	22.5	0.8	C312J224-9S****	0.0082	12.0	9.3	5.6	10.0	0.6	C313A822-4S****
0.0091	12.3	8.5	4.9	10.0	0.6	C312J912-4S****	0.24	25.2	15.5	8.2	22.5	0.8	C312J244-9S****	0.0091	12.0	9.5	5.9	10.0	0.6	C313A912-4S****
0.010	12.3	7.8	4.1	10.0	0.6	C312J103-4S****	0.27	25.2	15.9	9.2	22.5	0.8	C312J274-9S****	0.010	12.0	9.9	6.3	10.0	0.6	C313A103-4S****
0.011	12.3	7.9	4.2	10.0	0.6	C312J113-4S****	0.30	25.2	16.4	9.6	22.5	0.8	C312J304-9S****							
0.012	12.3	8.0	4.4	10.0	0.6	C312J123-4S****	0.33	25.2	16.8	10.0	22.5	0.8	C312J334-9S****							
0.013	12.3	8.1	4.5	10.0	0.6	C312J133-4S****	0.36	25.2	17.2	10.4	22.5	0.8	C312J364-9S****							
0.015	12.3	8.3	4.7	10.0	0.6	C312J153-4S****	0.39	25.2	17.6	10.8	22.5	0.8	C312J394-9S****							
0.016	12.3	8.5	4.8	10.0	0.6	C312J163-4S****	0.43	25.2	18.1	11.3	22.5	0.8	C312J434-9S****							
0.018	12.3	8.6	4.9	10.0	0.6	C312J183-4S****	0.47	25.2	18.6	11.8	22.5	0.8	C312J474-9S****							
0.020	12.3	8.8	5.1	10.0	0.6	C312J203-4S****	0.51	25.2	19.0	12.2	22.5	0.8	C312J514-9S****							
0.022	12.3	8.9	5.3	10.0	0.6	C312J223-4S****	0.56	25.2	19.6	12.8	22.5	0.8	C312J564-9S****							
0.024	12.3	9.1	5.5	10.0	0.6	C312J243-4S****														

- Note: 1. “-” =capacitance tolerance code, M=±20%,K=±10%,J=±5%
 2. “****” =lead form and packing code (refer to table 1)
 3. “#” when the rated voltage is 1250Vdc,the digit 4~5 is 3B.
 4. “@” Not suitable for across-the-line applications. Pls refer to interference Suppression Capacitors.

■ MAX. VOLTAGE(Vr.m.s) VERSUS FREQUENCY

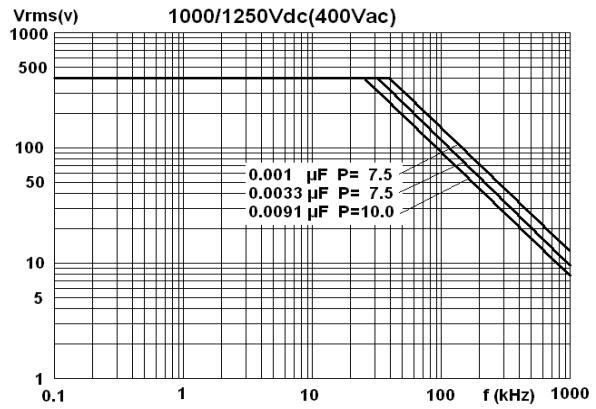
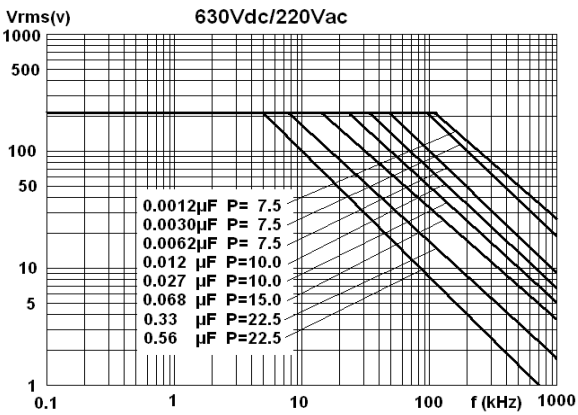
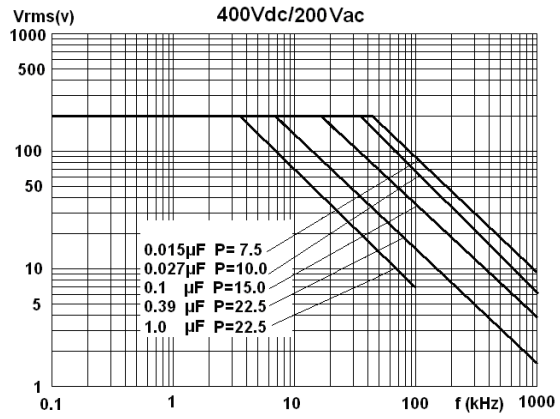
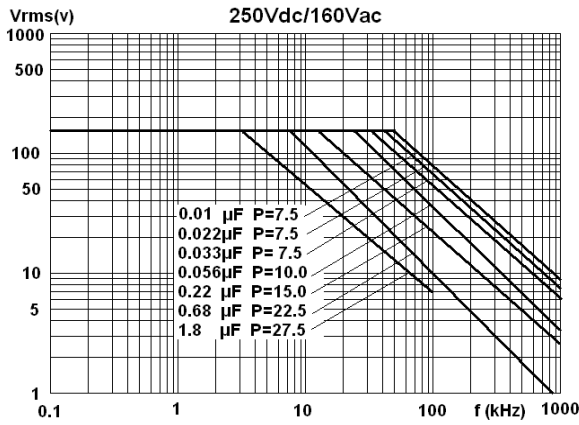

Note: sinusoidal wave-form, environment temperature $\leq 85^{\circ}\text{C}$, internal temperature rise $\Delta T=10^{\circ}\text{C}$, p (pitch) in mm.

■ Test Method And Performance

No.	Item	Performance	Test method(IEC 60384-16)
1	Solderability	Good quality of tinning	Solder temperature:245°C±5°C Immersion time: 2.0s±0.5s
2	Initial measurement	Capacitance Tgδ:1kHz, C>1.0μF 10kHz, C≤1.0μF	
	Terminal Strength (straight lead)	There shall be no visible damage	Tension: 0.6≤φd≤0.8mm, 10N φd=1.0mm, 20N Bend: 0.6≤φd≤0.8mm, 5N φd=1.0mm, 10N The terminals shall be bent 2 times in each direction.
	Resistance to solder heat	There shall be no visible damage	Solder temperature:260°C±5°C Immersion time: 10s±1s
	Final measurement	ΔC/C ≤±3%(relative to the initial value) Increase of tgδ: ≤0.004 (10kHz, C≤1.0μF) ≤0.004 (1kHz, C>1.0μF)	
3	Initial measurement	Capacitance Tgδ:1kHz, C>1.0μF 10kHz, C≤1.0μF	
	Rapid change of temperature	There shall be no evidence of deterioration.	θ _A =-40°C, θ _B =+105°C 5 cycles, Duration: t=30min
3	Vibration(straight lead)	There shall be no evidence of deterioration.	Amplitude 0.75mm or acceleration 98m/s ² (whichever is the smaller severity), f: 10Hz to 500Hz.Three directions, 2h for each direction, total 6h.
	Bump(straight lead)	There shall be no evidence of deterioration.	4 000 times, Acceleration: 390m/s ² ,Pulse duration, 6ms
	Final measurement	ΔC/C ≤±3%(relative to the initial value) Increase of tgδ: ≤0.004 (10kHz, C≤1.0μF) ≤0.004 (1kHz, C>1.0μF) IR: ≥ 50% of the rated value	
4	climate sequence	Initial measurement	Capacitance Tgδ:1kHz, C>1.0μF 10kHz, C≤1.0μF
		Dry heat	+105°C, 16h
		Damp heat, Cyclic	Test Db, Severity: b, the first cycle
		Cold	-40°C, 2h
		Low air pressure	There shall be no permanent breakdown, flashover or other harmful deformation when applying U _R at the last 1 minute. 15°C~ 35°C, 8.5kPa, 1h,

No.	Item		Performance	Test method(IEC 60384-16)
4	climate sequence (continue)	Damp heat, cyclic other		Test Db, Severity b, the other cycles, Applying U_R for 1 minute after the test finished.
		Final measurement	There shall be no evidence of deterioration and the marking shall be legible. $\Delta C/C \leq \pm 5\%$ (relative to the initial value) Increase of $\text{tg}\delta$: ≤ 0.005 (10kHz, $C \leq 1.0\mu\text{F}$) ≤ 0.005 (1kHz, $C > 1.0\mu\text{F}$) IR: $\geq 50\%$ of the rated value	
5	Damp heat steady state		There shall be no evidence of deterioration and the marking shall be legible. $\Delta C/C \leq \pm 5\%$ (relative to the initial value) Increase of $\text{tg}\delta \leq 0.002$ IR: $\geq 50\%$ of the rated value	Temperature: $40^\circ\text{C} \pm 2^\circ\text{C}$ Humidity: $93 \pm 3\%$ RH Duration: 21 days
6	Endurance		$\Delta C/C \leq \pm 5\%$ (relative to the initial value) Increase of $\text{tg}\delta$: ≤ 0.004 (10kHz, $C \leq 1.0\mu\text{F}$) ≤ 0.004 (1kHz, $C > 1.0\mu\text{F}$) IR: $\geq 50\%$ of the rated value	Temperature: $+85^\circ\text{C}$ Voltage: $1.25 \times U_R$ (50Hz) Duration: 1 000h
7	Temperature characteristic		Measuring capacitance at test point b, d, f: Characteristic at lower category temperature -40°C : $0 \leq (C_b - C_d) / C_d \leq +3\%$ Characteristic at upper category temperature $+85^\circ\text{C}$: $-3.25\% \leq (C_f - C_d) / C_d \leq 0$	Static method: The capacitors should be kept at the following temperature in turn: a. $(+20 \pm 2)^\circ\text{C}$ b. $(-40 \pm 2)^\circ\text{C}$ d. $(20 \pm 2)^\circ\text{C}$ f. $(+85 \pm 2)^\circ\text{C}$ g. $(+20 \pm 2)^\circ\text{C}$
8	Charging and discharging		$\Delta C/C \leq \pm 5\%$ (relative to the initial value) Increase of $\text{tg}\delta$: ≤ 0.005 (10kHz, $C \leq 1.0\mu\text{F}$) ≤ 0.005 (1kHz, $C > 1.0\mu\text{F}$) IR: $\geq 50\%$ of the rated value	Times: 10 000 Duration of charging: 0.5s Duration of discharging: 0.5s Charging voltage: rated voltage Charging resistance: $220/C_R$ (Ω) Discharging resistance: $R = 10/C_R$ (Ω) or 20Ω (whichever is the greater) C_R : rated capacitance (μF)

■ Marking (For example)

 104 K L  CBB21
 100 105 K 250 L
 $P \leq 10\text{mm}$ $P > 10\text{mm}$

Marking Introduction:

	Brand	CBB21	Type
100 250	Rated voltage	104 105	Rated capacitance
K	Tolerance	L	Year of manufacture

■ Taping for dipped-type capacitor

▲ Outline Drawing

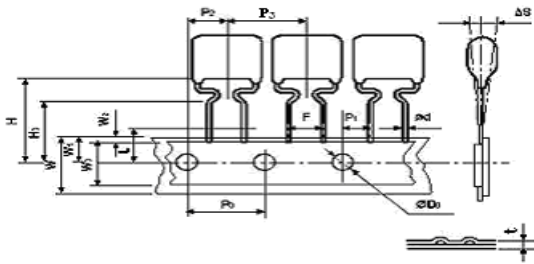

Fig.1

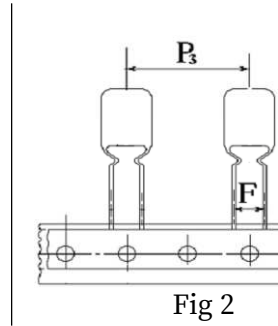

Fig 2

▲ Taping Dimensions(mm)

Technology index title	Code	Dimensions (mm)				Tolerance
		P=5.0	P=7.5	P=10.0	P=15.0	
Taping type	—	Fig 1	Fig 1	Fig 2	Fig 2	—
Part number Digit12-15	Ammo-pack	A21A	A31A	A41E	A61E	
Taping pitch	P ₃	12.7	12.7	25.4	25.4	±1.0
Feed hole pitch	P ₀	12.7	12.7	12.7	12.7	±0.3
Center of wire	P ₁	3.85	2.60	7.7	5.2	±0.7
Center of body	P ₂	6.35	6.35	12.7	12.7	±1.3
Pitch of taping wire	F ^{**}	5.0	7.5	10.0	15.0	+0.8 -0.2
Component alignment	△S	0	0	0	0	±2.0
Height of crangle from tape center	H	20.0	20.0	20.0	20.0	±1.0
Height of component from tape center	H ₀	16.0	16.0	16.0	16.0	±0.5
Carrier tape width	W	18.0	18.0	18.0	18.0	+1.0 -0.5
Hold down tape width	W ₀	10min	10min	10min	10min	—
Hole position	W ₁	9.0	9.0	9.0	9.0	+0.75 -0.5
Hold down tape sition	W ₂	3max	3max	3max	3max	—
Feed hole dia.	D ₀	4.0	4.0	4.0	4.0	±0.3
Tape thickness	t	0.7	0.7	0.7	0.7	±0.2

Note: * P₀=15mm is also available;
** F can be other lead spacing;

■ Soldering suggestions

▲ Manual soldering

Max. temperature: 350°C, time: 3s

▲ Wave soldering

There are many factors affecting the heating of film capacitor during the wave soldering process, such as: preheating temperature, preheating time, soldering temperature, soldering time, other heat sources influence and so on.

The typical soldering profile is as below:

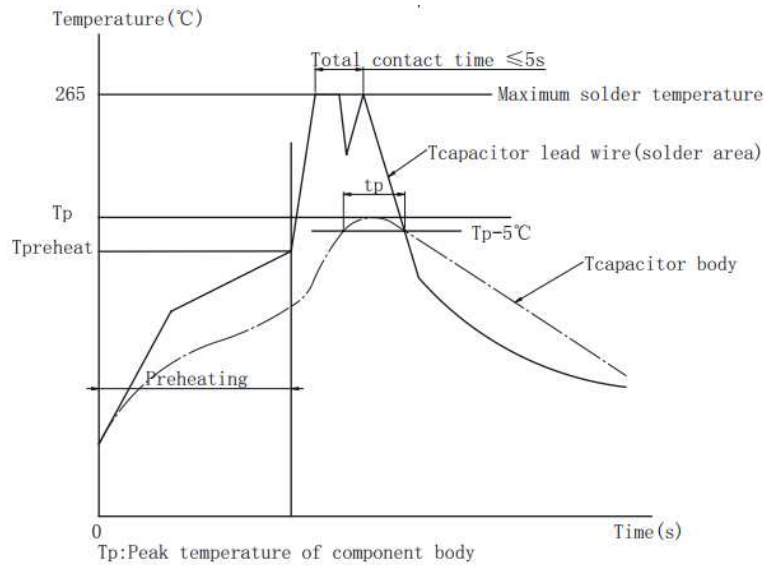

▲ Because overheating could damage the capacitor, we recommend paying attention to the maximum capacitor temperature and heating time, use temperature sensor to detect the maximum capacitor body temperature.

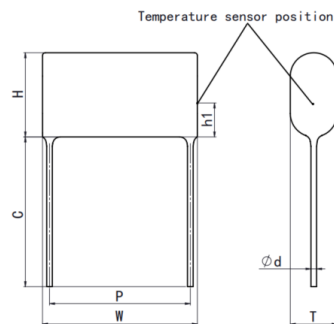

Note: If re-working or dipping twice is necessary, it should be done after the capacitor returns to the normal temperature.

Temperature sensor position (Tcapacitor body)	The capacitor body surface of lead side, capacitor height position from PCB: h1=2~3mm		
Maximum capacitor body temperature Tp(°C)	OPP film P≤15mm	OPP film P>15mm	PET film
	115	120	125
Maximum capacitor lead wire temperature (°C)	265	265	265
Maximum capacitor body heating time tp=Tp-5°C	30s		

■ Packing box sizes(mm)(example)

1. Out packing box for bulk

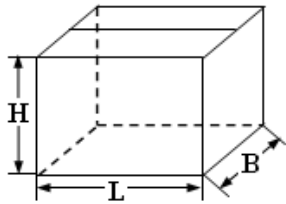

L:375±5
B:375±5
H:265±5

2. Inner packing box for bulk

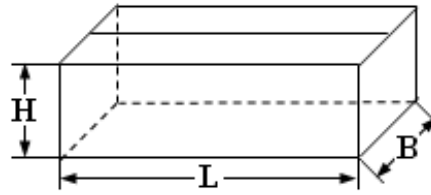

L:355±3
B:175±3
H:118±3

3. Box sizes for Ammo-pack

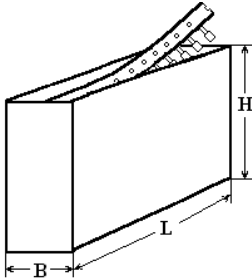

L:350±3
B:50±3
H:260±3

■ Storage conditions

▲ It must be noted that the solderability of the terminals may be deteriorated when stored in an atmosphere filled with moisture, dust, or a reactive oxidizing gas.(hydrogen chloride, hydrogen sulfide, sulfuric acid,etc.)

▲ It shouldn't be located in particularly high temperature and high humidity, it must submit to the following conditions(unchanging primal package):

Temperature: -40 °C to 35 °C

Humidity: Average per year ≤70%RH;

For 30 full days randomly distributed throughout the year ≤80%RH

Storage time for tinned lead wire: (from the date marked on the capacitor's body or the label glued to the package) :

Bulk(packed with plastic bag): ≤24 months ;

Taping and line up: ≤12 months