



## ULTRAFAST RECOVERY RECTIFIERS

VOLTAGE	100 to 600 Volts
CURRENT	10 Amperes

### FEATURES

- Plastic package has Underwriters Laboratory Flammability Classification 94V-0. Flame Retardant Epoxy Molding Compound.
- Low power loss, high efficiency.
- Low forward voltage, high current capability.
- High surge capability
- Ultra fast recovery time, high voltage.
- Lead free in comply with EU RoHS.

### MECHANICAL DATA

- Case: TO-220AC molded plastic
- Terminals: solder plated, solderable per MIL-STD-750, Method 2026
- Polarity: As marked.
- Mounting Position: Any

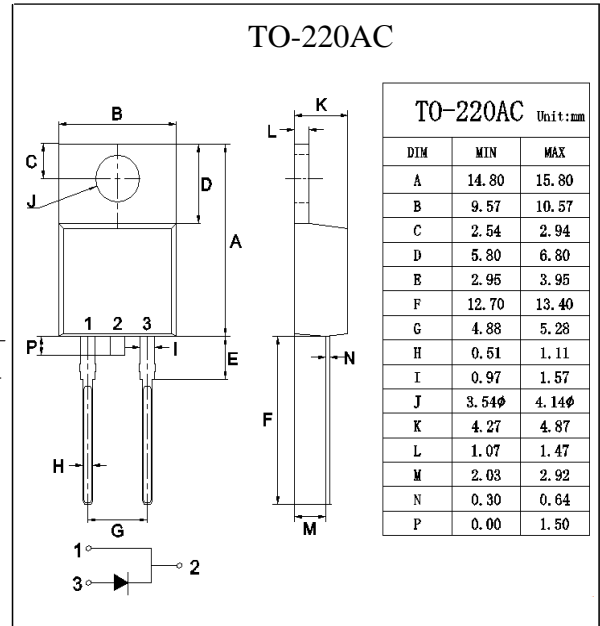

### MAXIMUM RATINGS AND ELECTRICAL CHARACTERISTICS

Ratings at 25°C ambient temperature unless otherwise specified. Single phase, half wave, 60 Hz, resistive or inductive load.

For capacitive load, derate current by 20%

PARAMETER	SYMBOL	MUR 1010	MUR 1020	MUR 1030	MUR 1040	MUR 1050	MUR 1060	UNITS
Maximum Recurrent Peak Reverse Voltage	$V_{RRM}$	100	200	300	400	500	600	V
Maximum RMS Voltage	$V_{RMS}$	70	140	210	280	350	420	V
Maximum DC Blocking Voltage	$V_{DC}$	100	200	300	400	500	600	V
Maximum Average Forward Current at $T_C = 100^\circ\text{C}$	$I_{F(AV)}$	10						A
Peak Forward Surge Current : 8.3ms single half sine-wave superimposed on rated load (JEDEC method)	$I_{FSM}$	110						A
Maximum Forward Voltage at 10A	$V_F$	1	1.3		1.7			V
Maximum DC Reverse Current at Rated DC Blocking Voltage $T_J=25^\circ\text{C}$ $T_J=125^\circ\text{C}$	$I_R$	10 500						$\mu\text{A}$
Typical Junction Capacitance (Note 1)	$C_J$	200						pF
Maximum Reverse Recovery Time (Note 2)	$t_{rr}$	35						ns
Typical Thermal Resistance (Note 3)	$R_{\theta JC}$	3						$^\circ\text{C} / \text{W}$
Operating Junction and Storage Temperature Range	$T_J, T_{STG}$	-55 to +150						$^\circ\text{C}$

#### NOTES:

1. Measured at 1 MHz and applied reverse voltage of 4.0 VDC.
2. Reverse Recovery Test Conditions:  $I_F=0.5\text{A}$ ,  $I_R=1\text{A}$ ,  $I_{rr}=0.25\text{A}$ .
3. Thermal resistance from Junction to case.



## RATING AND CHARACTERISTIC CURVES

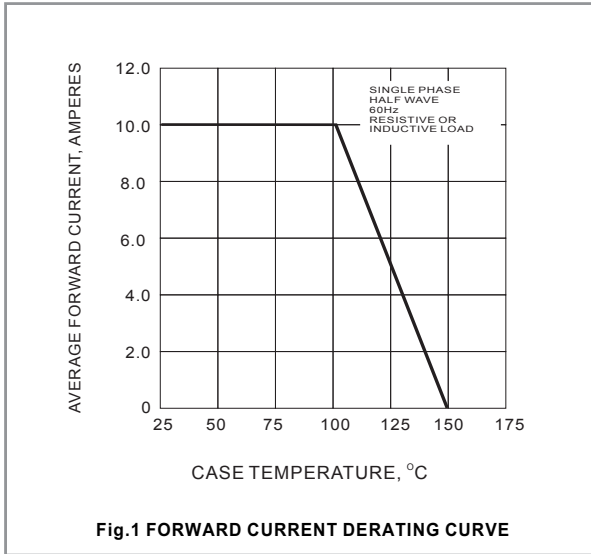

Fig.1 FORWARD CURRENT DERATING CURVE

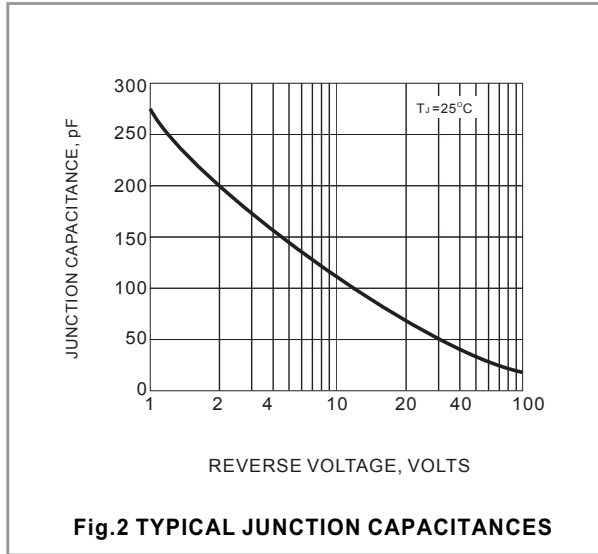

Fig.2 TYPICAL JUNCTION CAPACITANCES

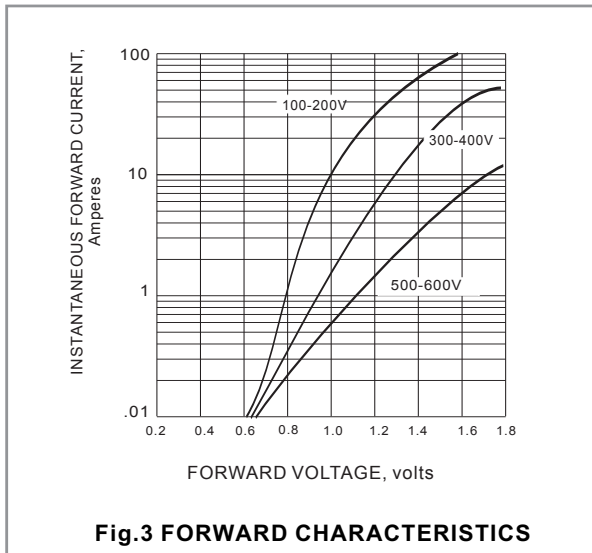

Fig.3 FORWARD CHARACTERISTICS

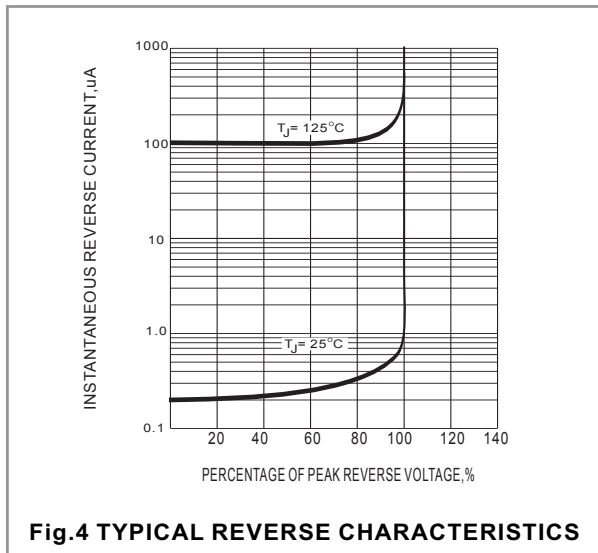

Fig.4 TYPICAL REVERSE CHARACTERISTICS

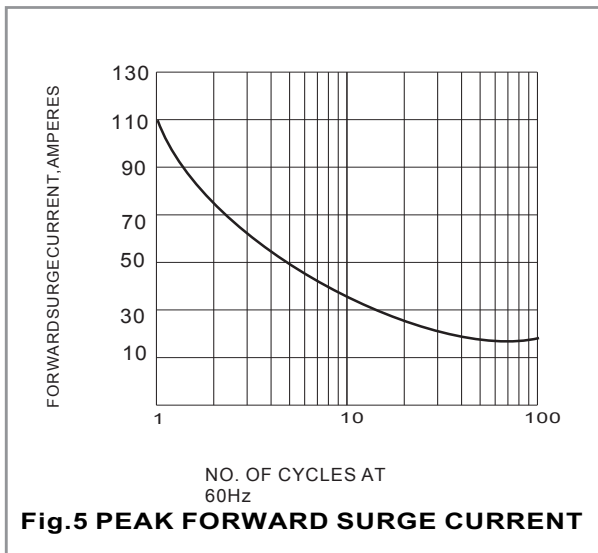

Fig.5 PEAK FORWARD SURGE CURRENT