

CSD95410 同步降压 NexFET™ 智能功率级

1 特性

- 90A 峰值持续电流
- 30A 电流下系统效率超过 95%
- 工作频率高 (高达 1.75 MHz)
- 二极管仿真功能
- 温度补偿双向电流检测
- 模拟温度输出
- 故障监控
- 兼容 3.3V 和 5V PWM 信号
- 三态 PWM 输入
- 集成自举开关
- 优化了击穿保护死区时间
- 高密度行业通用 5mm × 6mm QFN 封装
- 超低电感封装
- 系统已优化的 PCB 空间占用
- 耐热增强型顶部散热
- 符合 RoHS 标准、无铅端子镀层
- 无卤素

2 应用

- 多相同步降压转换器
 - 高频应用
 - 大电流、低占空比应用
- 负载点直流/直流转换器
- 存储器和显卡
- 台式机和服务器 VR12.x/VR13.x/VR14.x 电压内核同步降压转换器

3 说明

CSD95410 NexFET™ 功率级是经过高度优化的设计，用于高功率、高密度同步降压转换器。此产品集成了驱动器 IC 和功率 MOSFET 以实现功率级开关功能。该组合采用 5mm × 6mm 小型封装，可实现高电流、高效率以及高速切换功能。它还集成了准确电流检测和温度感测功能，以简化系统设计并提高准确度。此外，已对 PCB 封装进行了优化以帮助减少设计时间并简化总体系统设计的完成。

器件信息

器件	介质	数量	封装 ⁽¹⁾	配送
CSD95410	13 英寸卷带	2500	QFN 5.00mm × 6.00mm	卷带包装
CSD95410T	7 英寸卷带	250		

(1) 如需了解所有可用封装，请参阅数据表末尾的可订购产品附录。

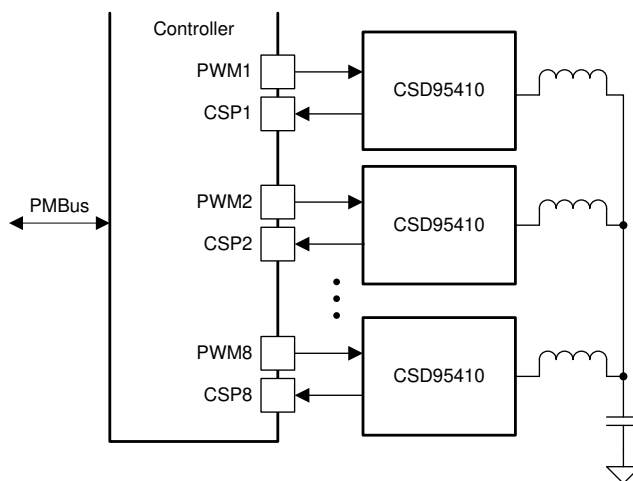

简化版应用



Table of Contents

1 特性	1	5.7 术语表.....	3
2 应用	1	6 Mechanical, Packaging, and Orderable Information ...	4
3 说明	1	6.1 Mechanical Drawing.....	4
4 Revision History	2	6.2 Recommended PCB Land Pattern.....	5
5 Device and Documentation Support	3	6.3 Recommended Stencil Opening.....	6
5.1 Device Support.....	3	6.4 Alternate Industry Standard Compatible PCB Land Pattern.....	7
5.2 Documentation Support.....	3	6.5 Alternate Industry Standard Compatible Stencil Opening.....	8
5.3 接收文档更新通知.....	3	6.6 Package Option Addendum.....	9
5.4 支持资源.....	3		
5.5 Trademarks.....	3		
5.6 静电放电警告.....	3		

4 Revision History

DATE	REVISION	NOTES
September 2020	*	Initial release.

5 Device and Documentation Support

5.1 Device Support

5.1.1 第三方产品免责声明

TI 发布的与第三方产品或服务有关的信息，不能构成与此类产品或服务或保修的适用性有关的认可，不能构成此类产品或服务单独或与任何 TI 产品或服务一起的表示或认可。

5.2 Documentation Support

5.3 接收文档更新通知

要接收文档更新通知，请导航至 ti.com 上的器件产品文件夹。点击 [订阅更新](#) 进行注册，即可每周接收产品信息更改摘要。有关更改的详细信息，请查看任何已修订文档中包含的修订历史记录。

5.4 支持资源

[TI E2E™ 支持论坛](#) 是工程师的重要参考资料，可直接从专家获得快速、经过验证的解答和设计帮助。搜索现有解答或提出自己的问题可获得所需的快速设计帮助。

链接的内容由各个贡献者“按原样”提供。这些内容并不构成 TI 技术规范，并且不一定反映 TI 的观点；请参阅 TI 的《[使用条款](#)》。

5.5 Trademarks

NexFET™ and TI E2E™ are trademarks of Texas Instruments.

所有商标均为其各自所有者的财产。

5.6 静电放电警告



静电放电 (ESD) 会损坏这个集成电路。德州仪器 (TI) 建议通过适当的预防措施处理所有集成电路。如果不遵守正确的处理和安装程序，可能会损坏集成电路。

ESD 的损坏小至导致微小的性能降级，大至整个器件故障。精密的集成电路可能更容易受到损坏，这是因为非常细微的参数更改都可能会导致器件与其发布的规格不相符。

5.7 术语表

TI 术语表

本术语表列出并解释了术语、首字母缩略词和定义。

- The package thermal pads must be soldered to the printed circuit board for optimal thermal and mechanical performance.

6.2 Recommended PCB Land Pattern

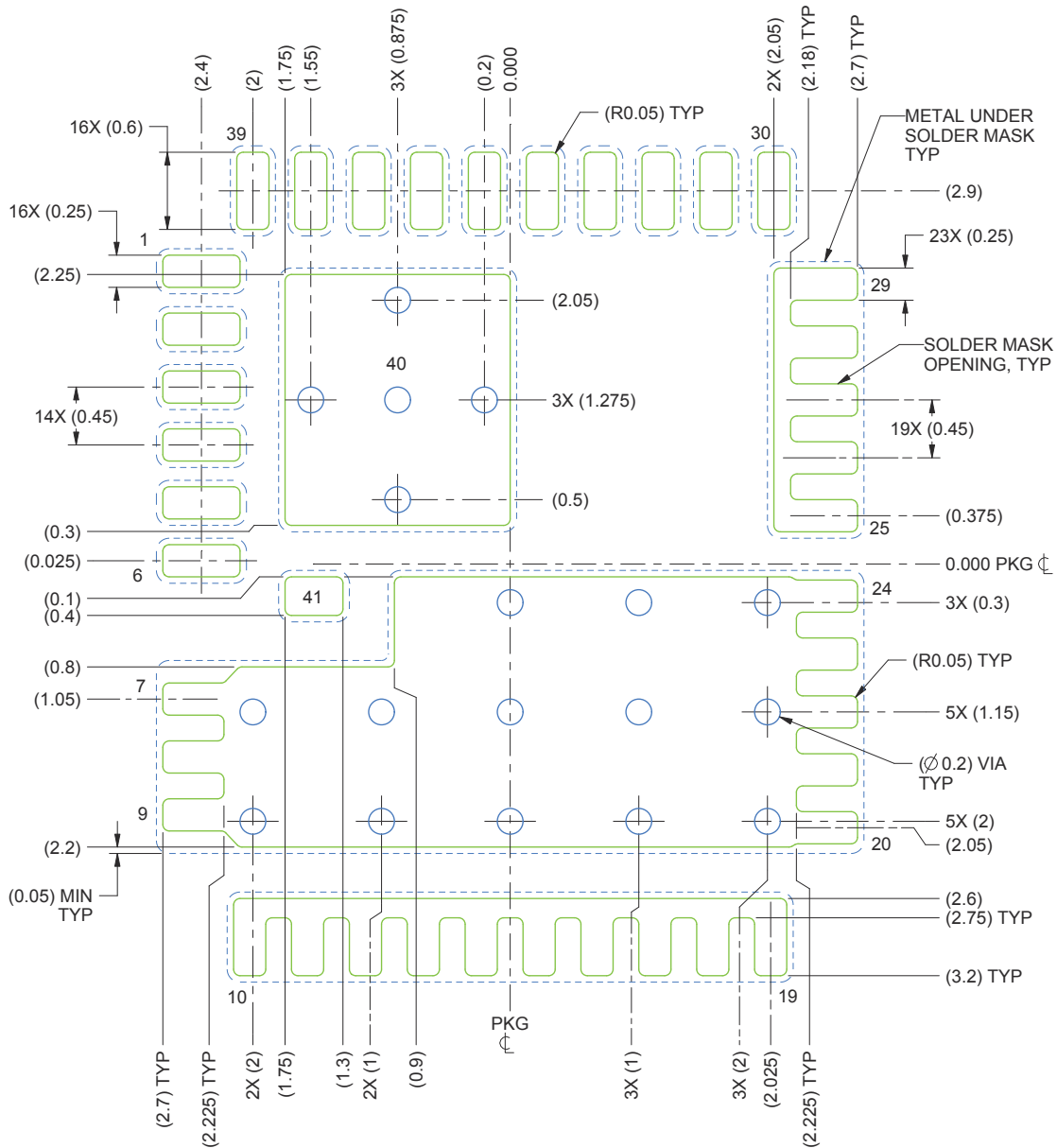

LAND PATTERN EXAMPLE
 SOLDER MASK DEFINED
 SCALE: 20X

4224073/A 03/2018

- All linear dimensions are in millimeters. Any dimensions in parenthesis are for reference only. Dimensioning and tolerancing per ASME Y14.5M.
- This drawing is subject to change without notice.
- This package is designed to be soldered to thermal pads on the board. For more information, see [QFN/SON PCB Attachment \(SLUA271\)](#).

6.3 Recommended Stencil Opening

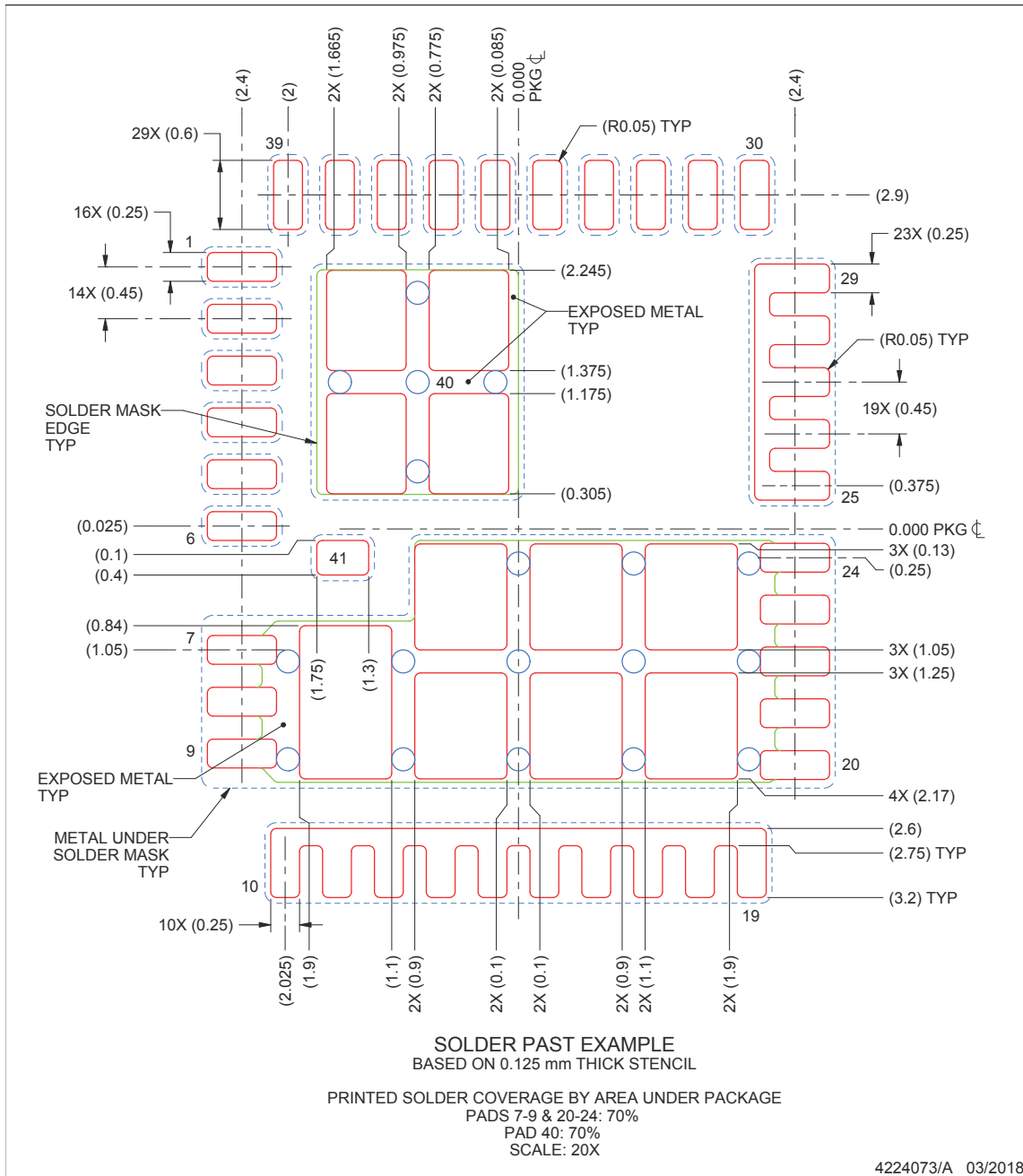

1. All linear dimensions are in millimeters. Any dimensions in parenthesis are for reference only. Dimensioning and tolerancing per ASME Y14.5M.
2. This drawing is subject to change without notice.
3. Laser cutting apertures with trapezoidal walls and rounded corners may offer better paste release. IPC-7525 may have alternate design recommendations.

6.4 Alternate Industry Standard Compatible PCB Land Pattern

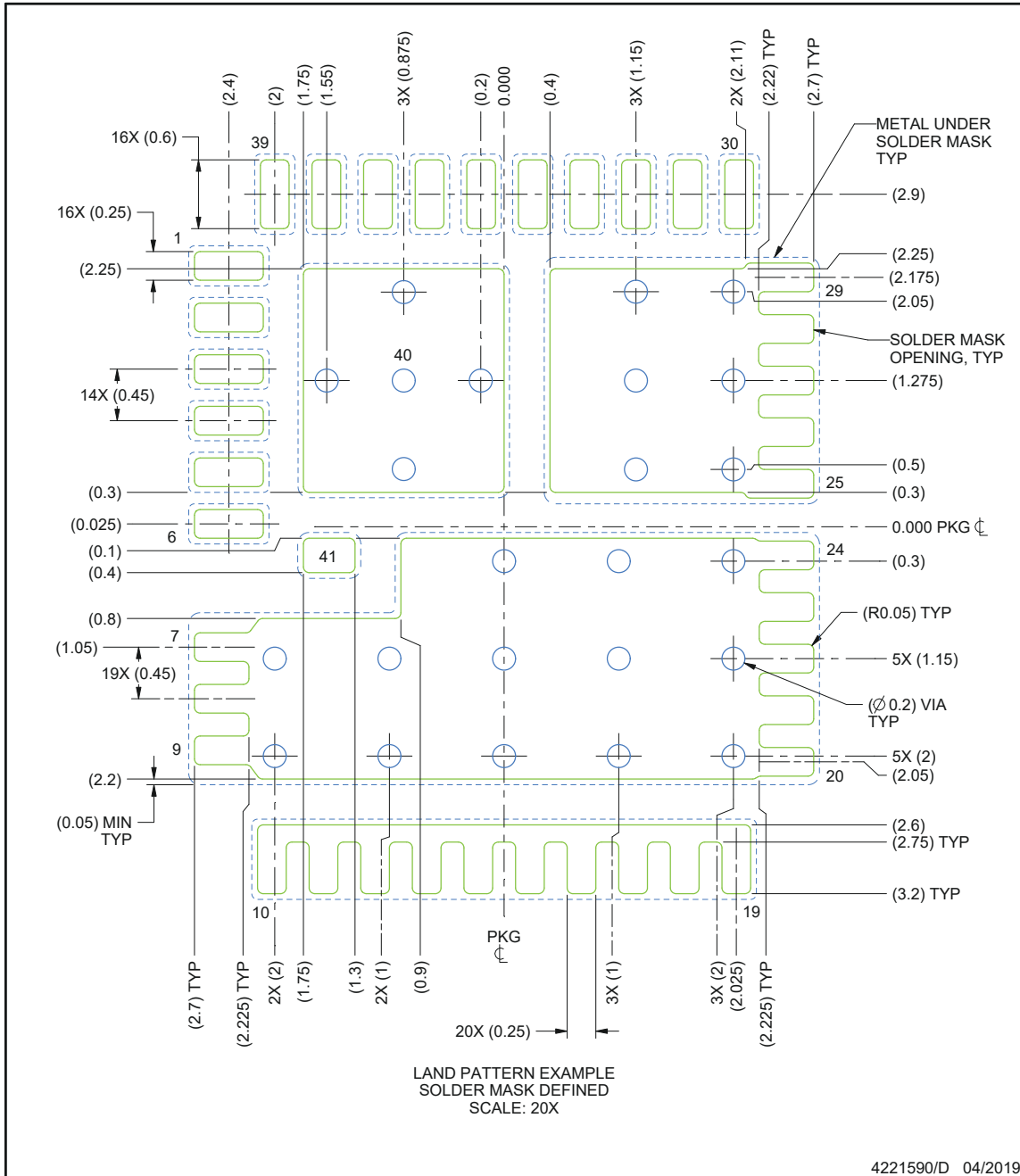

1. All linear dimensions are in millimeters. Any dimensions in parenthesis are for reference only. Dimensioning and tolerancing per ASME Y14.5M.
2. This drawing is subject to change without notice.
3. Laser cutting apertures with trapezoidal walls and rounded corners may offer better paste release. IPC-7525 may have alternate design recommendations.

6.5 Alternate Industry Standard Compatible Stencil Opening

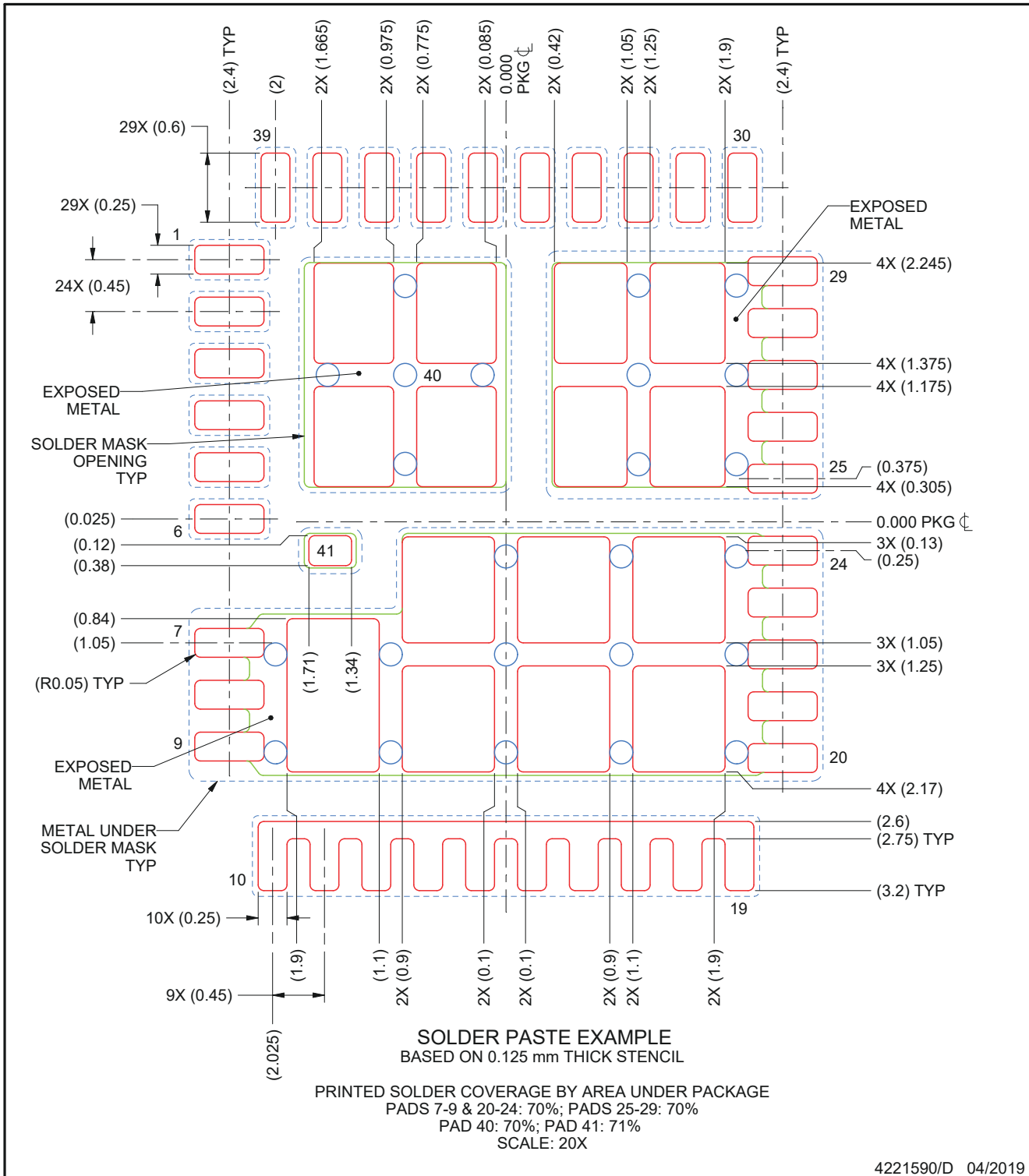

6.6 Package Option Addendum

PACKAGING INFORMATION

Orderable Device	Status (1)	Package Type	Package Drawing	Pins	Package Qty	Eco Plan (2)	Lead finish/ Ball material (6)	MSL Peak Temp (3)	Op Temp (°C)	Device Marking (4/5)	Samples
CSD95410RRB	ACTIVE	VQFN-CLIP	RRB	41	2500	RoHS-Exempt & Green	NIPDAU SN	Level-2-260C-1 YEAR	-40 to 125	95410RRB	Samples
CSD95410RRBT	ACTIVE	VQFN-CLIP	RRB	41	250	RoHS-Exempt & Green	NIPDAU SN	Level-2-260C-1 YEAR	-40 to 125	95410RRB	Samples

(1) The marketing status values are defined as follows:

ACTIVE: Product device recommended for new designs.

LIFEBUY: TI has announced that the device will be discontinued, and a lifetime-buy period is in effect.

NRND: Not recommended for new designs. Device is in production to support existing customers, but TI does not recommend using this part in a new design.

PREVIEW: Device has been announced but is not in production. Samples may or may not be available.

OBSOLETE: TI has discontinued the production of the device.

(2) **RoHS:** TI defines "RoHS" to mean semiconductor products that are compliant with the current EU RoHS requirements for all 10 RoHS substances, including the requirement that RoHS substance do not exceed 0.1% by weight in homogeneous materials. Where designed to be soldered at high temperatures, "RoHS" products are suitable for use in specified lead-free processes. TI may reference these types of products as "Pb-Free".

RoHS Exempt: TI defines "RoHS Exempt" to mean products that contain lead but are compliant with EU RoHS pursuant to a specific EU RoHS exemption.

Green: TI defines "Green" to mean the content of Chlorine (Cl) and Bromine (Br) based flame retardants meet JS709B low halogen requirements of <=1000ppm threshold. Antimony trioxide based flame retardants must also meet the <=1000ppm threshold requirement.

(3) MSL, Peak Temp. - The Moisture Sensitivity Level rating according to the JEDEC industry standard classifications, and peak solder temperature.

(4) There may be additional marking, which relates to the logo, the lot trace code information, or the environmental category on the device.

(5) Multiple Device Markings will be inside parentheses. Only one Device Marking contained in parentheses and separated by a "~" will appear on a device. If a line is indented then it is a continuation of the previous line and the two combined represent the entire Device Marking for that device.

(6) Lead finish/Ball material - Orderable Devices may have multiple material finish options. Finish options are separated by a vertical ruled line. Lead finish/Ball material values may wrap to two lines if the finish value exceeds the maximum column width.

Important Information and Disclaimer: The information provided on this page represents TI's knowledge and belief as of the date that it is provided. TI bases its knowledge and belief on information provided by third parties, and makes no representation or warranty as to the accuracy of such information. Efforts are underway to better integrate information from third parties. TI has taken and continues to take reasonable steps to provide representative and accurate information but may not have conducted destructive testing or chemical analysis on incoming materials and chemicals. TI and TI suppliers consider certain information to be proprietary, and thus CAS numbers and other limited information may not be available for release.

In no event shall TI's liability arising out of such information exceed the total purchase price of the TI part(s) at issue in this document sold by TI to Customer on an annual basis.

TAPE AND REEL INFORMATION

QUADRANT ASSIGNMENTS FOR PIN 1 ORIENTATION IN TAPE

*All dimensions are nominal

Device	Package Type	Package Drawing	Pins	SPQ	Reel Diameter (mm)	Reel Width W1 (mm)	A0 (mm)	B0 (mm)	K0 (mm)	P1 (mm)	W (mm)	Pin1 Quadrant
CSD95410RRB	VQFN-CLIP	RRB	41	2500	330.0	12.4	5.3	6.3	1.2	8.0	12.0	Q1
CSD95410RRBT	VQFN-CLIP	RRB	41	250	180.0	12.4	5.3	6.3	1.2	8.0	12.0	Q1

TAPE AND REEL BOX DIMENSIONS

*All dimensions are nominal

Device	Package Type	Package Drawing	Pins	SPQ	Length (mm)	Width (mm)	Height (mm)
CSD95410RRB	VQFN-CLIP	RRB	41	2500	367.0	367.0	38.0
CSD95410RRBT	VQFN-CLIP	RRB	41	250	213.0	191.0	35.0

重要声明和免责声明

TI“按原样”提供技术和可靠性数据（包括数据表）、设计资源（包括参考设计）、应用或其他设计建议、网络工具、安全信息和其他资源，不保证没有瑕疵且不做任何明示或暗示的担保，包括但不限于对适销性、某特定用途方面的适用性或不侵犯任何第三方知识产权的暗示担保。

这些资源可供使用 TI 产品进行设计的熟练开发人员使用。您将自行承担以下全部责任：(1) 针对您的应用选择合适的 TI 产品，(2) 设计、验证并测试您的应用，(3) 确保您的应用满足相应标准以及任何其他功能安全、信息安全、监管或其他要求。

这些资源如有变更，恕不另行通知。TI 授权您仅可将这些资源用于研发本资源所述的 TI 产品的应用。严禁对这些资源进行其他复制或展示。您无权使用任何其他 TI 知识产权或任何第三方知识产权。您应全额赔偿因在这些资源的使用中对 TI 及其代表造成的任何索赔、损害、成本、损失和债务，TI 对此概不负责。

TI 提供的产品受 [TI 的销售条款](#) 或 [ti.com](#) 上其他适用条款/TI 产品随附的其他适用条款的约束。TI 提供这些资源并不会扩展或以其他方式更改 TI 针对 TI 产品发布的适用的担保或担保免责声明。

TI 反对并拒绝您可能提出的任何其他或不同的条款。

邮寄地址：Texas Instruments, Post Office Box 655303, Dallas, Texas 75265

Copyright © 2023，德州仪器 (TI) 公司